

Exhibit “A”

September 19, 2023



Barbara Fryer, AICP
Director, City of Cornelius Community Development Department
1335 North Barlow Street
Cornelius, OR 97113

RE: Completeness Review of Cornelius South Commercial Type III Site Design Review and Type II Preliminary Land Partition

Dear Barbara:

Thank you for reviewing the Cornelius South Commercial Site Design Review and Partition application. This letter and accompanying information respond to your request for additional information that we received in the letter dated August 25, 2023 (attached). The additional information requested is shown in *italics*, with the applicant's response directly below.

1. *Provide a signed Type II Preliminary Land Partition Review Checklist. (The list provided was for subdivisions.)*

Response: A Type II Preliminary Land Partition Review Checklist is included with the updated application materials (Exhibit B).

2. *Provide details for the proposed trash enclosure, including food waste enclosure for the restaurant (see CMC 5.60).*

Response: Details for the trash enclosure are included with the updated Preliminary Plans (Exhibit A). Sheet A1.03 identifies the food waste area in the covered enclosure area.

3. *Provide details for the proposed bicycle parking.*

Response: Details for the planned bicycle parking are included with the updated Preliminary Plans (Exhibit A) and discussed in the updated narrative. See Sheet A.1.02 for the bike rack details.

4. *Provide details [for] the proposed fencing. Please note, it is difficult to ascertain the location of the new fencing, per Sheet C100 Detail #20.*

Response: Additional details of the planned fencing are included with the updated Preliminary Plans (Exhibit A). See Sheet C100 for the location and Sheet A1.21 for the fencing detail.

5. *Please demonstrate the required 10-vehicle reservoir requirement within the drive-thru lane. (If a menu board or height bar is proposed at the entrance of the drive-thru, staff recommends including these details, within the application packet.)*

Response: A diagram depicting the 10-space queuing reservoir is included on Sheet C100 in the updated Preliminary Plans (Exhibit A). The planned location of the menu board and height bar are shown on Sheet C100 and can be further assessed upon building permit review.

6. *The provided on-site parking count utilizes the "other" category, within the Eating and Drinking Establishment of the parking table, please see below. The Coffee shop should utilize 12.4/1,000 sf*

when calculating parking for this use. Please adjust the site plan and your on-site parking calculations accordingly. As shown, the site is overparked and cannot be recommended for approval.

No parking calculations were provided that justify the parking spaces on parcel 2. Please provide these calculations and adjust the plans accordingly. Staff also notes a space for a future trash enclosure on parcel 2 should be noted. Please note construction of the enclosure and specific detail for the enclosure is not required, just the location noted on the plans.

Response: The application narrative has been updated and maximum parking has been calculated using the standards for a fast-food restaurant (12.4 spaces per 1,000 square feet). The parking area is planned to be shared across both parcels and therefore parking is shown on both parcels in the updated Preliminary Plans. The updated application narrative addresses future uses anticipated on Parcel 2 and how the maximum parking standard is planned to be met following development on Parcel 2.

The planned trash enclosure has been noted on the updated Preliminary Plans and trash enclosure details are provided. The planned trash enclosure is intended to serve uses on both parcels and is sized appropriately to serve both parcels. Therefore, a trash enclosure is not shown on Parcel 2.

7. An easement to the water quality facility located on parcel 2 from parcel 1 is necessary.

Response: As shown on Sheet C300 in the updated Preliminary Plans (Exhibit A), on-site underground stormwater treatment is planned to treat runoff on Parcel 1. The above-ground stormwater treatment facility on Parcel 2 is planned to treat runoff from Parcel 2 only. Therefore, an easement for the water quality facility on Parcel 2 is not necessary.

8. As noted within the narrative, the State adopted the Climate-Friendly and Equitable Communities (CFEC) rules. Please provide surface area calculations for the parking lots for each parcel and address the following;

Per OAR 660-012-0405(4), parking lot designs change for development with more than ¼ acre of surface parking on the lot or parcel, as follows:

- a. Provide one of the following:*
 - A. Install solar panels with a generation capacity of at least 0.5 KW per parking space on the property. Panels can be located anywhere on the property or a fee of \$1,500 per parking space can be paid; or*
 - B. Comply with OAR 330-135-0010, which requires 1.5 percent for green energy technology in public building construction contracts; or*
 - C. Provide tree canopy covering at least 50 percent of the parking lot at maturity, but no later than 15 years after planting*
- b. street trees along driveways, but not drive aisles*
- c. street-like design and features along driveways including curbs, pedestrian facilities, and buildings built up to pedestrian facilities.*
- d. any tree canopy plan must be done in coordination with local electric utility including pre-design, design, building, and maintenance phases*
- e. tree spacing and species must be designed to maintain a continuous canopy, maximum root health and survival, 2021 ANSI A300 standards, and a maintenance provision.*

Response:

This application includes a parking area across both parcels that exceeds the 0.5-acre threshold for the CFEC standards to apply. The applicable CFEC standards will be met by providing tree canopy per OAR 660-012-0405(4)(a)(C). According to the implementation guidance for OAR 660-012-0405, cities can “set reasonable exemptions for paved areas not for use by passenger vehicles” when calculating the parking area to be counted toward the 0.5-acre threshold of OAR 660-012-0405(4). The Preliminary Tree Canopy Shade Plan (Sheet L101) in the updated Preliminary Plans demonstrates the area on both parcels to be considered “surface parking area” for purposes of meeting these requirements (±29,634 square feet). This area was calculated to exclude the loading and driveway areas on the south portion of the project site as well as the drive-through queuing aisle on Parcel 1. This shading plan demonstrates greater than 40 percent coverage of the parking area, as calculated based on the Implementation Guidelines for OAR 660-012-0405.

Additional standards of OAR 660-012-405(4) include:

- (b) Developments must provide either trees along driveways or a minimum of 30 percent tree canopy coverage over parking areas. Developments are not required to provide trees along drive aisles. The tree spacing and species planted must be designed to maintain a continuous canopy, except when interrupted by driveways, drive aisles, and other site design considerations; and*
- (c) Developments must provide pedestrian facilities between building entrances and pedestrian facilities in the adjacent public right-of-way.*
- (d) Development of a tree canopy plan under this section shall be done in coordination with the local electric utility, including pre-design, design, building, and maintenance phases.*
- (e) In providing trees under subsections (a) and (b) the following standards shall be met. Trees must be planted and maintained to maximize their root health and chances for survival, including having ample high-quality soil, space for root growth, and reliable irrigation according to the needs of the species. Trees should be planted in continuous trenches where possible. The city or county shall have minimum standards for planting and tree care no lower than 2021 American National Standards Institute A300 standards, and a process to ensure ongoing compliance with tree planting and maintenance provisions.*

The Tree Canopy Plan included with the Preliminary Plans (Sheet L101, Exhibit A), demonstrates tree canopy coverage of at least 30 percent. Pedestrian facilities are included between building entrances and adjacent sidewalks along the S 1st Avenue and W Baseline Street rights-of-way. The tree canopy plan will be implemented in coordination with the local electric utility (PGE) to ensure there are no conflicts between

the planned trees and electric utilities. The planned trees will meet the standards of subsection (e) above. Therefore, CFEC standards are met as applicable.

9. *Near the entrance of S 1st Avenue, at the driveway, there are multiple potential vehicle turning and maneuvering conflicts. Please evaluate this area and where needed provide traffic control measures.*

Response: The updated Preliminary Plans demonstrate a 10-space queuing area for the planned drive-through. The parking area improvements are planned to include directional signage and striping to provide adequate guidance to vehicles using the parking area. Additionally, the driveway entrance area at S 1st Avenue is large enough to accommodate the anticipated vehicle traffic and queuing in this area.

10. *Provide 5 additional copies of the complete application packet, as amended, per the information above (and below); one full electronic copy of the application packet (thumb-drive with a PDF or drop box link) and one copy of the application packet that is unbound and 8 ½" x 11" in size.*

Response: The required materials are included herein.

Thank you for your review of these application materials. Please let us know if you have questions.

Sincerely,

AKS ENGINEERING & FORESTRY, LLC



Melissa Slotemaker, AICP
12965 SW Herman Road, Suite 100
Tualatin, OR 97062
503-563-6151 | slotemakerm@@aks-eng.com

Attachments:

City of Cornelius Completeness Review Letter, dated August 25, 2023
5 copies of updated application materials
1- Full-size plan set
1- 8.5"x11" copy of application materials
Electronic copy of application materials (thumb drive)

Cornelius South Commercial Partition and Site Design Review

Date: July 2023 (Updated September 2023)

Submitted to: City of Cornelius
Department of Community Development
1355 N. Barlow Street
Cornelius, OR 97113

Applicant: Nathan Palmer
200 E Palm Valley Dr., Ste. 1080
Oviedo, FL 32765

AKS Job Number: 9656



12965 SW Herman Road, Suite 100
Tualatin, OR 97062
(503) 563-6151

Table of Contents

I.	Executive Summary.....	2
II.	Site Description/Setting	2
III.	Applicable Review Criteria	2
	CORNELIUS MUNICIPAL CODE	2
	Title 17 Subdivisions.....	2
	Title 18 Zoning.....	11
IV.	Conclusion	42

Exhibits

- Exhibit A: Preliminary Plans (Updated September 2023)**
 - Exhibit B: Application Forms and Checklists (Updated September 2023)**
 - Exhibit C: Ownership Information**
 - Exhibit D: Washington County Assessor’s Map**
 - Exhibit E: Clean Water Services
Service Provider Letter**
 - Exhibit F: Preliminary Stormwater Report**
 - Exhibit G: Notes from Pre-Application Conference (PAC-16-22)**
 - Exhibit H: Neighborhood Meeting Documentation**
 - Exhibit I: ODOT Comments**
-

Cornelius South Commercial Partition and Site Design Review

Submitted to:	City of Cornelius Department of Community Development 1355 N. Barlow Street Cornelius, OR 97113
Applicant:	Nathan Palmer 200 E Palm Valley Dr., Ste. 1080 Oviedo, FL 32765
Property Owner:	Ann Snyder Tilden Revocable Trust 6865 SW Canyon Drive Portland, OR 97225
Applicant's Consultant:	AKS Engineering & Forestry, LLC 12965 SW Herman Road, Suite 100 Tualatin, OR 97062 Contact: Melissa Slotemaker, AICP Email: slotemakerm@aks-eng.com Phone: (503) 563-6151
Site Location:	A vacant lot at the southeast corner of the intersection of S 1 st Avenue and W Baseline Street at the western boundary of the City of Cornelius.
Washington County Assessor's Map:	Map 1S304BB, Tax Lot 300
Site Size:	±2.32 acres
Land Use Districts:	Highway Commercial (C-2)

I. Executive Summary

AKS Engineering & Forestry is submitting this application on behalf of Nathan Palmer (Applicant) for a Type III Site Design Review and Land Partition on a ±2.32-acre parcel in the City of Cornelius. The application includes the division of the subject property into three parcels to facilitate commercial development. Additionally, the application includes a new commercial building and parking area on Parcel 1 (as shown in the Preliminary Plans) and new stormwater and parking facilities on Parcels 1 and 2. A future commercial building on Parcel 2 is planned to be processed through a separate Site Design Review permit at a later date.

The planned commercial building will include multiple commercial uses including a dentist's office and a coffee shop with a drive-through window. A vehicle queueing area is planned to be provided for the drive-through window. A shared parking area is also planned in conjunction with the commercial building on Parcel 1 and the anticipated future use(s) on Parcel 2. The parking area includes landscaping, pedestrian pathways, curbs, and striping. The building is planned on Parcel 1 and will take access from an existing driveway on S 1st Avenue. Secondary access will be taken via a right-in, right-out driveway onto W Baseline Street on Parcel 2 that is planned to be shared with an adjacent commercial property to the east. Tract A contains an existing vegetated corridor and is not planned to be impacted by this project.

The total parking area included with this project is greater than 0.5 acres and is therefore required to meet the Climate Friendly and Equitable Communities (CFEC) standards of OAR 660-012-0405. The Preliminary Tree Canopy Shade Plan in the Preliminary Plans (Exhibit A) demonstrates the area used to calculate the parking area for purposes of implementing the requirements of OAR 660-012-0405(4). The planned parking area improvements include tree canopy coverage exceeding 40 percent of the parking area in accordance with CFEC standards.

This application includes the City application forms, written materials, and preliminary plans necessary for City staff to review and determine compliance with the applicable approval criteria. The evidence is substantial and supports the City's approval of the application.

II. Site Description/Setting

The subject property is located at the southeast intersection of W Baseline Street and S 1st Avenue (Washington County Assessor's Map 1S304BB, Tax Lot 300). The property currently includes two curb cuts for vehicle access along S 1st Avenue but is otherwise unimproved. The southern portion of the property (±18,761 square feet) is located in a vegetated corridor. The site is bordered by W Baseline Street to the north, adjacent commercial property to the east, Southern Pacific Railroad right-of-way to the south, and S 1st Avenue to the west.

III. Applicable Review Criteria

CORNELIUS MUNICIPAL CODE

Title 17 Subdivisions

Chapter 17.05 Land Divisions

17.05.030 Land partitioning.

(A) Requirements for Land Partitioning Actions.

- (1) No person shall partition an area, parcel or tract of land without the approval of the planning commission or the community development

director in accordance with the standards and regulations contained in this section.

Response: This application includes a land partition and is being submitted for review by the Planning Commission and the Community Development Director. The applicable standards for a land partition are addressed by this written narrative. This requirement is met.

(2) The standards and regulations of this section shall apply to partitions of land as defined in ORS 92.010(9).

Response: This application includes a partition as defined by ORS 92.010(9). The standards and regulations of this section are applicable.

(3) The community development director shall coordinate and assemble through the facilities and design review process the reports and data submitted by the applicant, affected city departments and any governmental agencies having an interest in partitions. The community development director shall determine whether the partition meets the criteria in subsection (C) of this section.

Response: This requirement is understood.

(4) The community development director shall approve, approve with conditions or deny the proposed partition in writing based on the criteria of subsection (C) of this section, within 45 days of submittal of a complete application.

Response: This requirement is understood.

(5) Notice and review of the community development director's decision shall be pursuant to CMC 18.15.030.

Response: This requirement is understood.

(6) If the area or tract of land to be partitioned exceeds two acres, and within one calendar year is being partitioned into more than two parcels, any one of which is less than one acre, full compliance with all requirements for subdivision may be required if the community development director or planning commission determines that the entire parcel being partitioned is in the process of being divided into lots or tracts which would otherwise be subject to subdivision regulations if the partitioning did not occur within one calendar year.

Response: This requirement is understood.

(B) Application Requirements. The community development director shall provide forms that specify the information required for submission of land partitions. The applicant shall prepare a map together with other supplementary material as may be required and shall submit the necessary number of copies to the community development director.

Response: This requirement is understood and can be met.

(C) Approval Criteria. A request to partition land must meet all of the following criteria:

(1) The proposal conforms with the city's comprehensive plan; and

Response: The subject property is in the Highway Commercial (C-2) zoning district and is intended for commercial uses. This application includes a Site Design Review for a new commercial building on Parcel 1 of the planned partition. Following the planned partition, Parcel 2 is

intended to be improved with a commercial building in the future in accordance with the zoning district and comprehensive plan designation. Therefore, this criterion is met.

- (2) The proposal complies with all applicable statutory and ordinance requirements and regulations; and

Response: As demonstrated by this narrative and the application materials, the planned partition meets all applicable requirements. This criterion is met.

- (3) Adequate public facilities are available to serve the proposal; and

Response: As demonstrated by the Preliminary Plans (Exhibit A) and discussed elsewhere in this narrative, adequate public facilities exist to serve the parcels following the planned partition. This criterion is met.

- (4) All proposed lots conform to the size and dimensional requirements of this chapter; and

Response: As demonstrated by the Preliminary Plans (Exhibit A), the planned partition will create three parcels that will conform to the size and dimensional standards of this chapter. This criterion is met.

- (5) All proposed improvements meet city standards.

Response: As demonstrated by the Preliminary Plans (Exhibit A), the planned improvements are planned to meet City standards. This criterion is met.

- (D) Required Improvements. For any partitioning of land, where applicable, the following design and development standards and requirements may apply to partitions. These standards shall apply at the point of construction of improvements and/or land developments. The community development director shall have the authority to impose any such standards or requirements as conditions of approval.

Response: This standard is understood and addressed in responses to the sections below.

- (E) Streets. The location, width and grade of streets shall be considered in relation to existing and planned streets, to topographical conditions, to public convenience and safety, and to the proposed use of the land to be served by such streets. Where location is not shown in the comprehensive plan, the arrangement of the streets in a land division shall either:

- (1) Provide for the continuation or appropriate projection of existing principal streets in surrounding areas; or
- (2) Conform to standards adopted by the city. All streets shall be designed in accordance with standards set forth in the adopted Cornelius public works standards.

All streets and alleys within the development and those adjacent streets which directly serve the development shall be fully improved, including grading, base grade, paving, and installation of curbs, all constructed to design specifications as approved by the city engineer. All streets to be constructed and/or improved shall comply with the minimum street improvement standards contained in this title. In cases where physical conditions warrant it, special soils analysis or engineering designs may be required by the city engineer. In addition, where a proposed partition abuts a substandard arterial or collector street, the developer shall provide to the community development director, prior to final plat approval, adequate guarantees that, within one year from the issuance of a building permit for construction within the

development, such as abutting arterial or collector street or streets shall be improved in a manner which is compatible with the standards for streets contained in this title. Adequate guarantee shall consist of formation of a local improvement district or provision of a security in an amount sufficient to cover the estimated actual improvement cost, plus 15 percent.

Response: As demonstrated by the Preliminary Plans (Exhibit A), street improvements to N 1st Avenue and W Baseline Street are included with the planned improvements and meet the standards of this section. This standard is met.

(F) Easement.

(1) Utility Lines. Easements for sewers, drainage, water mains, electric lines, or other utilities shall be dedicated. Easements for water, sewer, or drainage on interior lot lines shall be 20 feet in width, the center line of which shall be the lot lines. Easements for water, sewer, or drainage along exterior lot lines shall be 20 feet in width, except no easement will be required for those lot lines paralleling a street or other public way. Tie-back easements shall be six feet wide and 20 feet long along lot side lines at change of direction points of the lot lines. Easements for utilities such as electrical, gas, cable, and fiber optics (public utility easement, or PUE) shall be dedicated along all right-of-way frontages, including woonerfs, and shall be eight feet in width. A PUE is not required along the right-of-way of an alley, unless a parcel on an alley does not also front on a street or woonerf directly.

Response: As demonstrated by the Preliminary Plans (Exhibit A), easements are provided for utilities as applicable. This standard is met.

(2) Watercourses. Where a land division is traversed by a watercourse, drainage way, channel, or stream, a storm water easement or drainage right-of-way conforming substantially to the lines of such watercourse, and such further width as will be adequate for the purpose, may be required. Streets or parking ways parallel to watercourses may be required. Watercourse easements and drainage rights-of-way shall be consistent with Clean Water Services (CWS) standards.

Response: An existing wetland, storm drainage easement, and vegetated corridor in accordance with CWS standards are located within Tract A at the southern boundary of the site. This standard is met as applicable.

(G) Lot Size and Shape. Lot size, width, shape and orientation shall conform to the requirements of this title for the applicable zoning district.

Response: As demonstrated by the Preliminary Plans (Exhibit A), the planned partition conforms to the minimum lot standards of the C-2 zoning district. This standard is met.

(H) Access. Each lot shall abut upon a public street, for a distance of at least 20 feet, and comply with CMC 18.143.050, Access standards.

Response: As demonstrated by the Preliminary Plans (Exhibit A), the partition is planned to create two parcels with greater than 20 feet of frontage on a public street. Further findings pertaining to access standards can be found in responses to CMC 18.143.050 below. This standard is met.

-
- (I) Dedications. Public streets, sidewalks, pedestrian ways, bike paths, parks, open space, and other public rights-of-way required by or reasonably related to the development shall be dedicated or otherwise conveyed to the city or the appropriate jurisdiction for maintenance. Further, any park or open space proposed may be required to be dedicated to the public if it is designated in the city's comprehensive plan. An appropriate instrument granting or conveying the park or open space must be approved by the jurisdiction to whom the park or open space is being dedicated prior to final plat approval.

Response: As demonstrated by the Preliminary Plans (Exhibit A), the planned partition includes dedications for public facilities as applicable. This standard is met.

- (J) Utilities. All utilities shall be placed underground per standards identified by the city engineer.

Response: As demonstrated by the Preliminary Plans (Exhibit A), all utilities are planned to be underground. This standard is met.

- (K) Street Trees. Trees shall be installed along street frontages in accordance with the adopted Cornelius public works standards. Actual location and spacing of trees shall be at the discretion of the city engineer.

Response: As demonstrated by the Preliminary Plans (Exhibit A), trees meeting the street tree standards of this code are provided along the frontage of S 1st Avenue on the east side of the existing sidewalk, in accordance with the adopted Cornelius public works standards. Street trees are planned in this location in conjunction with input from City staff during the pre-application conference and will avoid impacts to the existing sidewalk along S 1st Avenue. This project does not include street trees along W Baseline Street due to ODOT regulations regarding trees adjacent to highways and the presence of overhead/future underground electric utilities along the landscape strip. Therefore, this standard is met as applicable.

- (L) Compliance with Approvals.

- (1) Requirements Prior to Commencement of Work. Prior to any construction, improvements or land development, the developer shall perform the following:

- (a) The developer shall file detailed plans and specifications for all public improvements or land development together with a detailed cost estimate and an estimate of time reasonably necessary to complete such improvements for approval by the city engineer or designee.

Response: This requirement is understood and will be met prior to commencement of work.

- (b) The developer shall enter into a contract with the city of Cornelius to make, install and complete within the time fixed, but in no case more than two years from the date of execution of said contract without written approval by the city engineer and community development director, all improvements in accordance with the approved plans prior to acceptance of the improvements by the city and/or plat recordation. If the developer chooses to bond for said improvements prior to acceptance of the improvements (to allow plat recordation to occur prior to completion of the public improvements), the developer shall cause to be filed

with the city recorder a security acceptable to the community development director payable to the city of Cornelius in a principal sum determined from the approved estimate of the costs of said improvements of this section. The security shall assure the performance of the said contract and the completion of the said improvements, free of liens. Notwithstanding any of the above, a security shall be provided for any improvements to be performed within public rights-of-way and/or public easements, and all erosion control measures.

Response: This requirement is understood and will be met.

- (c) The amount of the security shall be based on an estimate of the cost of the work approved by the city engineer in accordance with the following schedule:
 - (i) Public and private improvements within public rights-of-way and/or public easements, and all erosion control measures, in conformance with city and Clean Water Services standards, equals 150 percent of cost estimate.

Response: This requirement is understood and will be met.

- (2) Improvement Procedures. All improvements shall conform to the requirements of this chapter and any other improvements standards or specifications adopted by resolution of the city council and shall be installed in accordance with the following procedures:
 - (a) Improvement work shall not be commenced until plans have been checked for adequacy and approved by the city. To the extent necessary for evaluation of the land division proposal, such plans may be required before approval of the final plat.

Response: This requirement is understood and will be met.

- (b) Improvement work shall not be commenced until the developer has secured the appropriate development permit. If work has been discontinued for any reason, it shall not be resumed until the city has been notified and consented in writing.

Response: This requirement is understood and can be met.

- (c) All required improvements shall be constructed under the inspection and to the specifics of the city engineer, adopted Cornelius public works standards, and Cornelius Municipal Code. The city may require changes in typical sections and details if unusual conditions arise during construction to warrant such change in the interests of the city or the developer. Upon acceptance of the required improvements, the city engineer shall notify the developer that the improvements are acceptable as per Cornelius Municipal Code. Acceptance shall be in writing.

Response: This requirement is understood and will be met.

- (d) All underground utilities, sanitary sewers, storm drains and cable communication system facilities installed in streets shall be constructed prior to the surfacing of such streets.

Stubs for service connections for all underground utilities, sanitary sewers and cable communication system facilities shall be placed to such length as will obviate the necessity for disturbing the street improvements when service connections are made.

Response: This requirement is understood and is planned to be met.

- (e) A map showing all public improvements as built shall be filed with the city engineer upon completion of said improvements.

Response: This standard is understood and will be met.

- (3) Improvement Requirements. Improvements to be installed at the expense of the developer are as follows:

- (a) Streets.
 - (i) All streets, including alleys.
 - (ii) Streets adjacent but only partially within the partition or subdivision.
 - (iii) The extension of the land division streets to the intercepting paving line of existing streets with which the land division streets intersect.
 - (iv) Arterial or collector streets which intersect with streets within the development that provide ingress or egress to the development or on which there are traffic impacts reasonably related to the development.
 - (v) All streets shall be built in accordance with adopted Cornelius public works standards and the adopted Cornelius transportation system plan.

Response: As demonstrated by the Preliminary Plans (Exhibit A), public street improvements are planned as part of this application and are planned to meet the Cornelius public works standards for local (S 1st Avenue) and arterial (W Baseline Street) streets. This standard is met.

- (b) Surface Drainage and Storm Sewer System. Drainage facilities shall be provided within the land division to connect the land division drainage to drainage ways or storm sewers outside the land division. Design of drainage shall be in accordance with adopted Cornelius public works standards and shall allow for the extension of the system to serve other areas.

Response: As demonstrated by the Preliminary Plans (Exhibit A), the planned improvements include underground stormwater treatment facilities on Parcel 1 (to serve Parcel 1) and above-ground stormwater facilities on Parcel 2 (to serve Parcel 2). As discussed in the Stormwater Report (Exhibit F), the planned stormwater facilities facilitate connections with the City's stormwater system and conform to the applicable Public Works standards. Therefore, this standard is met.

- (c) Sanitary Sewers. Sanitary sewers shall be designed in accordance with adopted Cornelius public works standards

and installed to serve the land division and to connect the land division to existing mains.

Response: As demonstrated by the Preliminary Plans (Exhibit A), the planned improvements include sanitary sewer systems that will connect to existing mains and serve the planned parcels. A sanitary sewer easement is provided between Parcels 1 and 2 for sanitary sewer service. Sanitary sewer lines are planned to meet the Cornelius public works standards. This standard is met.

- (d) **Water System.** Water lines with valves and fire hydrants serving the land division, connecting the land division to city mains, shall be installed in conformance with the adopted Cornelius public works standards. The design and construction by the developer shall take into account provisions for extension beyond the land division and to adequately grid the city system.

Response: As demonstrated by the Preliminary Plans (Exhibit A), the planned improvements include water lines serving the planned parcels and future commercial buildings. Planned improvements also include fire hydrants. Water lines are planned to connect to existing mains and meet the Cornelius public works standards. Therefore, this standard is met.

- (e) **Street Trees.** Street trees shall be planted along street frontages in accordance with the following:
 - (i) For all land divisions, the developer shall pay a per tree security to the city. The surety bond shall be based upon the number of trees included in an approved street tree plan.
 - (ii) Trees shall be planted in accordance with the adopted Cornelius public works standards.

Response: As demonstrated by the Preliminary Plans (Exhibit A), the planned improvements include street trees along the street frontage of S 1st Avenue. Trees are planned to meet the minimum requirements of the Cornelius public works standards. Street trees are not included along W Baseline Street due to ODOT regulations regarding trees adjacent to highways and the presence of overhead/future underground electric utility lines along the landscape strip. These standards are met as applicable.

- (f) **Bike and Pedestrian Ways.** Bike and pedestrian ways shall be constructed according to adopted Cornelius public works standards.

Response: As demonstrated by the Preliminary Plans (Exhibit A), the planned improvements include bicycle and pedestrian ways along W Baseline Street as well as pedestrian facilities along S 1st Avenue as required by the Cornelius public works standards. This standard is met.

- (g) **Other improvements reasonably related to the impacts of the development which may be required at the partial or total expense of the developer:**
 - (i) Improvement of arterial and collector streets providing primary access to land division streets.
 - (ii) Signals, traffic control devices, and traffic calming devices.

-
- (iii) Intersection improvements.
 - (iv) Parks and open space shall be improved as required by the city and/or appropriate jurisdiction.

Response: As demonstrated by the Preliminary Plans (Exhibit A), this project includes street improvements to S 1st Avenue (a local street) and W Baseline Street (an arterial road). Improvements to S 1st Avenue include landscape strips with street trees on the east side of the existing sidewalk. Improvements to W Baseline Street include sidewalks, landscape strips, a bike lane, and a bus turnout. Additionally, this application includes open space ("Tract A" on the Preliminary Plans) that is intended to contain the vegetated corridor on the subject property. This standard is met as applicable.

- (h) **Street Lights.** Street lights shall be installed in accordance with adopted Cornelius public works standards.

Response: The subject property abuts S 1st Avenue (a local street) and W Baseline Street (an arterial street under ODOT jurisdiction). As demonstrated by the Existing Conditions sheet in the Preliminary Plans (Exhibit A), there are existing streetlights on the west side of S 1st Street; therefore, streetlights are not necessary along this street. There are also existing streetlights along W Baseline Street mounted on existing PGE overhead power poles. This project does not include streetlights along W Baseline Street due to ODOT regulations regarding highways and the presence of overhead/future underground electric utilities. This standard is met as applicable.

- (i) **Curb cuts and driveway installations are not required of the developer but, if installed, shall be according to adopted Cornelius public works standards.**

Response: As demonstrated by the Preliminary Plans (Exhibit A), the planned improvements include curb cuts and driveways to serve the planned parcels and future commercial buildings. The planned curb cuts and driveway are planned to meet the Cornelius public works standards. Therefore, this criterion is met.

- (j) **Internal sidewalks or pathways shall be provided to ensure safe and convenient pedestrian circulation throughout the development.**

Response: As demonstrated by the Preliminary Plans (Exhibit A), pedestrian circulation facilities are included with this application and connect public sidewalks to building entrances on the subject property. Pedestrian pathways provide safe and convenient access to entrances, parking areas, and public sidewalks. Therefore, this standard is met.

- (4) **Final Plat Approval.** The community development director shall review the final plat for compliance with the approved preliminary plat. If the community development director determines that the final plat conforms to the approved preliminary plat, the community development director shall so certify and sign the final plat. If the final plat does not conform, it shall be returned to the developer to correct the deficiencies and must be resubmitted for approval within the time established by the community development director.

Response: This standard is understood.

-
- (5) Filing of Final Plat. Approval of the final plat by the city as provided by this regulation shall be conditioned on its prompt recording. The developer shall, without delay, submit the final plat for signatures of other public officials required by law. Approval of the final plat shall be null and void if the plat is not recorded within 30 days after the date the last required approving signature has been obtained. Prior to issuance of any development permits the applicant shall provide to the planning department one copy of the recorded final plat signed by all public officials.

Response: This standard is understood and will be met.

(M) Time Limit on Approvals.

- (1) The developer shall submit a plat, including a survey, within 12 months after approval of the partition.

Response: This standard is understood.

- (2) The community development director may grant time extensions allowing up to 12 additional months for platting of the partition if justifiable cause is shown; however, a time extension cannot be granted to allow platting to be submitted more than two years from the date the partition was approved.

Response: This standard is understood.

- (3) If the developer wishes to proceed with the partition and has not submitted the plat within the required time or approved extensions of time, the developer shall resubmit the preliminary plat to the community development director with appropriate information and a fee for reprocessing the request according to the provisions for partition approval in effect at the time of resubmission.

Response: This standard is understood.

Title 18 Zoning

Chapter 18.45 Highway Commercial Zone (C-2)

18.45.020 Uses permitted outright.

In a C-2 zone the following uses shall be permitted outright; provided, that all operations are conducted within an enclosed structure:

- (A) General retail.
- (B) Service commercial, including barber, banks.
- (C) Automobile, truck, marine, motorcycle, appliance and/or parts sales, service, repair, rental, and including custom vehicle assembly; provided, that all operations are conducted within an enclosed structure.
- (D) Office, including professional, medical/dental.
- (E) Indoor amusement or entertainment and restaurants, including fast food with drive-up window.
- (F) Motel, motor courts, hotel, inns or bed and breakfasts.
- (G) Small engine or equipment repair shop.
- (H) Single-family dwelling units as a secondary or accessory use to commercial.
- (I) Other similar uses as may be approved by the planning commission.

-
- (J) Type “A” or Type “B” mobile vendor, as described in Chapter 5.35 CMC; this use is not subject to the enclosed structure requirement.

Response: This project includes two new commercial buildings to be occupied by office and general commercial uses including a drive-through commercial restaurant. These uses are permitted outright by this section. Therefore, this standard is met.

(...)

18.45.040 Development requirements.

- (A) Lot Size. In a C-2 zone there is no minimum lot size, save and except that the lot must be large enough to accommodate the proposed use, including all design standards and functional requirements related to the use.

Response: The subject property is ±2.32 acres and as demonstrated by the Preliminary Plans (Exhibit A), is large enough to accommodate the proposed uses while meeting the design standards and functional requirements related to those uses. Therefore, this standard is met.

- (B) Setback Requirements. In a C-2 zone the following setbacks shall meet the base standard; however, the review body may require a greater or lesser setback based on the design review criteria set forth in this chapter:

- (1) The front yard shall be 10 feet, except that:

(a) Parking shall be allowed within five feet of the front property line.

(b) For all properties abutting the south side of Baseline Road, there shall be a front yard setback equal to five percent of the average lot depth, but not less than four feet.

Response: As demonstrated by the Preliminary Plans (Exhibit A), the planned multi-use building and the parking area meet the front yard setback standards of this section. This standard is met.

- (2) No side yard shall be required, except five feet when abutting a residential use or zone, and when a side yard abuts a public street the setback shall be the same as the front yard.

Response: The subject property is bordered by S 1st Avenue to the east and W Baseline Street to the north. The front property line is along W Baseline Street. As demonstrated by the Preliminary Plans (Exhibit A), the side yard setback along S 1st Avenue is the same as the front yard setback along W Baseline Street. Setback standards will also be reviewed at building permit submittal. This standard is met.

- (3) No rear yard is required, except five feet when abutting a residential use or zone, and when a side yard abuts a public street the setback shall be the same as the front yard.

Response: The rear property line of the subject property abuts the Southern Pacific Railroad right-of-way. As demonstrated by the Preliminary Plans (Exhibit A), there are also significant wetlands and an associated vegetated corridor along the rear property line that require an additional setback. These sensitive lands and affiliated setbacks are elsewhere in this narrative below. This standard is not applicable and additional rear setbacks required by the sensitive lands are addressed later in this narrative.

-
- (C) **Height of Building.** No building shall exceed a height of 35 feet, unless approved by the planning commission.

Response: As demonstrated by the elevations shown in the Preliminary Plans (Exhibit A), the planned multi-use buildings will be less than 35 feet tall. This standard is met.

18.45.050 Performance standards.

In a C-2 zone no land or structure shall be used or occupied unless there is continuing compliance with the following standards:

- (A) **Design Review Approval.** All design review requirements and conditions of approval, including all prior attached conditions shall be satisfied.

Response: This requirement is understood.

- (B) **Environmental Standards.** All uses shall comply with required air, land, and water quality standards set forth by all state, federal and local jurisdictions (i.e., Department of Environmental Quality, Clean Water Services, and Metro).

Response: This standard is understood and will be met. A Service Provider Letter from CWS is provided as Exhibit E.

- (C) **Heat and Glare.**

- (1) Except for exterior lighting, operations producing heat or glare shall be conducted entirely within an enclosed structure, such that glare is not visible from a public street or adjacent property.
- (2) Exterior lighting shall be designed such that glare is directed away from public streets or adjacent properties.

Response: As demonstrated by the Preliminary Site Lighting Plan in the Preliminary Plans (Exhibit A), exterior lighting planned as part of this project will be directed away from public streets and adjacent properties. The planned improvements will not produce heat and glare. This standard is met.

- (D) **Insects and Rodents.** Materials including wastes shall be managed and stored, and grounds shall be maintained in a manner that will not attract or aid the propagation of insects or rodents or create a health hazard.

Response: This standard is understood.

- (E) **Outside Storage.** Outside storage shall be appropriately screened consistent with CMC 18.45.060(F).

Response: This project includes two new multi-use buildings to be occupied by office and general commercial uses including a drive-through commercial restaurant. There is no outdoor storage included as part of this project. This standard is not applicable.

18.45.060 Development Standards

In a C-2 zone no new use or occupation of land or a structure or a new structure and no change of use of land or a structure shall be permitted unless there is continuing compliance with the following standards:

- (A) **Landscape Plan.**

- (1) For all uses in a C-2 zone, the first five feet of lineal street frontage on the subject site shall be landscaped (exclusive of frontage trees) prior

to occupancy, in accordance with the approved site plan and the standards set forth herein.

Response: As demonstrated by the Preliminary Landscape Plan in the Preliminary Plans (Exhibit A), street frontages along S 1st Avenue and W Baseline Street will be landscaped as part of the planned improvements to the site. Further landscaping standards are addressed elsewhere in this section. This standard is met.

- (2) When at maturity, at least 80 percent of the proposed landscape area shall be covered by plant material, lawn, and trees. The remaining area may be covered in nonvegetative ground cover.

Response: As demonstrated by the Preliminary Landscape Plan in the Preliminary Plans (Exhibit A), the landscaping included as part of the planned improvements will meet the 80 percent standard described in this section. This criterion is met.

- (3) **Street Trees.** Street trees shall be required and shall be selected from the approved public works street tree list. The total number of trees shall be determined by dividing the total linear footage of the site, which abuts a public street, by 30 feet. The location of the trees shall be determined through design review, and the trees shall be installed in accordance with Chapter 5 of the adopted public works standards.

Response: As demonstrated by the Preliminary Landscape Plan in the Preliminary Plans (Exhibit A), the planned improvements include street trees along S 1st Avenue that meet the standards of this section. Street trees along W Baseline Street are not included with this project due to ODOT regulations regarding trees adjacent to highways and existing overhead/future underground electric utility lines along the landscape strip where trees would be planted. Therefore, this standard is met as applicable.

- (4) Installation of required landscaping may be deferred for up to six months; provided, that the owner posts with the city a cash deposit or irrevocable letter of credit assigned to the city for an amount equal to 150 percent of the estimated cost of the landscaping materials and installation by a qualified contractor.

Response: This standard is understood.

(B) Vehicular Access, Internal Circulation and Clear Vision Areas.

- (1) Where possible, vehicular access to commercial developments shall be from abutting arterial or collector streets, and shall be shared with adjacent properties to minimize multiple curb cuts. Access to individual lots from T.V. Highway shall be approved by ODOT with secondary access from adjacent collectors or minor local streets where possible. Except in the case of a multi-building complex, direct lot access to an arterial shall not be permitted, unless there is no viable alternative, and direct access to collector and local streets shall only be allowed as permitted by the review body.

Response: The subject property has frontage on S 1st Avenue and W Baseline Street (T.V Highway). Primary access is provided on S 1st Avenue and consists of a two-way drive aisle. Secondary access is provided via a right-in, right-out driveway on W Baseline Street at the northeast corner of the property. The secondary access is intended to be shared with the adjacent property to the east and a shared access easement is planned in conjunction

with this project. It is understood that the planned access onto W Baseline Street is subject to ODOT review. This standard is met as applicable.

- (2) The minimum public street width for commercial development shall comply with Chapter 5 of the adopted public works standards.

Response: As demonstrated by the Preliminary Plans (Exhibit A), the subject property abuts two public streets (S 1st Avenue and W Baseline Street) that meet the minimum street width requirements for commercial developments. This standard is met.

- (3) Internal Access. All internal roadways and drives shall be paved and maintained by the owner in accordance with city standards. No entrance or exit shall be located closer than 100 feet to any intersection of a public street, unless there is no reasonable alternative. They shall have the following minimum unobstructed pavement width:

- (a) Two-way traffic: 24 feet;
(b) One-way traffic: 15 feet.

Response: As demonstrated by the Preliminary Plans (Exhibit A), entrances to the subject property are located on S 1st Avenue and W Baseline Street. Both entrances are greater than 100 feet from the intersection of S 1st Avenue and W Baseline Street. The access on S 1st Street is planned to be used by two-way traffic and have an unobstructed pavement width greater than ±24 feet. The access on W Baseline Street will be right-in, right-out traffic only and will also have an unobstructed pavement width of ±24 feet. These standards are met.

- (4) Internal sidewalks or pathways shall be provided to ensure safe and convenient pedestrian circulation throughout the development.

Response: As demonstrated by the Preliminary Plans (Exhibit A), sidewalks and pathways are planned to provide safe and convenient pedestrian access between the buildings and adjacent streets. This standard is met.

- (5) Clear vision areas shall be provided at all roadway and driveway intersections in accordance with the vision clearance standards set forth in CMC 18.150.070.

Response: As demonstrated by the Preliminary Landscape Plan in the Preliminary Plans (Exhibit A), clear vision areas will be provided at the driveway intersections on S 1st Avenue and W Baseline Street. A clear vision area will also be maintained at the intersection of S 1st Avenue and W Baseline Street. These areas will meet the standards of CMC 18.150.070. This standard is met.

(C) Access Streets – Sidewalks – Drainage

- (1) All streets shall be designed in accordance with Chapter 5 of the adopted public works standards.

Response: As demonstrated by the Preliminary Plans (Exhibit A), the planned improvements include landscape strips and street trees along S 1st Avenue and sidewalks, landscape strips, a bike lane, and a bus turnout on W Baseline Street. These improvements are designed to comply with Chapter 5 of the public works standards. This standard is met.

-
- (2) All driveways for new construction shall have minimum pavement width of 12 feet and shall not be more than 35 feet in width at the curb, unless specifically approved by the review body to meet unusual requirements of a particular use. Each driveway shall have a concrete curb apron designed to comply with public works standards.

Response: As demonstrated by the Preliminary Plans (Exhibit A), the planned driveways will meet or exceed 12 feet of pavement width and will not exceed 35 feet in width at the curb. Curb aprons will be provided to comply with public works standards. This standard is met.

- (3) Cul-de-sacs shall serve no more than four separate uses and shall have a minimum turning radius of 50 feet measured to the front edge of the curb.

Response: The planned improvements do not include cul-de-sacs. This standard is not applicable.

- (4) Sidewalks and Improvements.

- (a) For all new construction, curbs, gutters, and a minimum six-foot-wide sidewalk, with eight feet at a bus stop, shall be provided along the entire lot frontage, and shall meet ADA accessibility standards.

Response: The subject property is bordered by S 1st Avenue to the west and W Baseline Street to the north. Current improvements to S 1st Avenue along the subject site include a sidewalk and two existing driveway curb cuts. The northern driveway curb cut does not align with planned improvements to the site. Therefore, frontage improvements are planned for S 1st Avenue as part of this project and include new curbs, gutters, landscape strips, and street trees. Existing sidewalks on S 1st Avenue will be retained.

There are currently no sidewalks or related improvements along W Baseline Street (T.V. Highway). This application includes sidewalks, curb cuts, gutters, and landscape strips along W Baseline Street. A portion of the sidewalk is adjacent to a bus turnout and is planned to be ±8 feet wide. Other planned sidewalks are designed to be at least ±6 feet wide and meet ADA requirements. This standard is met.

- (b) Site design review Type II requests for remodels, alterations and/or additions to an existing building shall require a sidewalk if one does not exist, the driveway apron and paved driveway to be constructed to city standards. Commercial sidewalks shall be curb tight, unless otherwise approved by the review body.

Response: This project includes a new multi-use building on a site that is currently vacant. There are no existing buildings on the site; therefore, this standard is not applicable.

- (5) Storm drainage shall be managed through a system of underground drainage lines and catch basins, which convey storm water off the site to a public storm system, and shall comply with Clean Water Services (CWS) standards for water quality and quantity.

Response: This application includes a partition to create three parcels. A new commercial building is planned on Parcel 1, as demonstrated by the Preliminary Plans (Exhibit A). Parcel 1 is planned to be served by an underground stormwater facility on the south portion of the parcel that will convey stormwater to the adjacent public system in S 1st Street. Parcel 2

is planned to be served by an above-ground stormwater treatment facility in an existing vegetated area on the south portion of the property. As demonstrated by the Preliminary Stormwater Report (Exhibit F), the planned stormwater facilities are adequate to serve their respective parcels. A CWS Service Provider Letter is provided as Exhibit E. This standard is met.

(D) **Lighting Streets.** Streets and walkways shall be lighted during the hours of darkness in accordance with public works standards.

Response: As demonstrated by the Existing Conditions sheet in the Preliminary Plans (Exhibit A), there are existing streetlights on the west side of S 1st Street; therefore, streetlights are not necessary along this street. There are also existing streetlights along W Baseline Street mounted on existing PGE overhead power poles. This project does not include streetlights along W Baseline Street due to ODOT regulations regarding highways and the presence of overhead/future underground electric utilities. As shown on the Preliminary Site Lighting Plan in the Preliminary Plans, walkways adjacent to the planned building will be illuminated according to the standards of the CMC. This standard is met as applicable.

(E) **Mailboxes.** Except for in-fill partitioning, clustered mailboxes shall be provided, consistent with the locational criteria set by the Post Master. They shall be of uniform style.

Response: This standard is understood, and mailboxes will be provided in locations approved by the postmaster. The location of mailboxes can be reviewed at the time of building permit application for the planned building on Parcel 1. This standard is met as applicable.

(F) **Screening.**

(1) **Sight-obscuring screening shall be provided for all garbage and trash collection areas, and for any approved outdoor storage, or parking lots abutting a residential development. Such screening shall be six feet in height, and shall consist of a wall of brick, stone, or other substantial material, or a densely planted evergreen hedge and a decorative fence, such as wrought-iron, or PVC or polymer covered chain link fencing. Galvanized chain link fencing shall not be permitted on new construction.**

Response: The planned improvements include a trash enclosure. The trash enclosure is intended to serve uses on both Parcels and is sized appropriately to serve both parcels. As demonstrated by the Preliminary Plans (Exhibit A), screening is planned around the enclosure and will meet the standards of this section. The planned improvements do not include outdoor storage and the subject site does not abut a residential zoning district. This standard is met as applicable.

(2) **The reviewing body may require nonsight-obscuring screening and/or fencing of parking lots abutting property lines, front yards abutting a public street, or other yards abutting a residential development.**

Response: This standard is understood.

(G) **Parking and Loading Space.**

(1) **Off-Street Parking.** Parking shall be provided as set forth in Chapter 18.145 CMC.

Response: Please see responses to the criteria of Chapter 18.145 later in this narrative. This standard is met.

- (2) **Paving and Design.** Off-street parking and maneuvering areas shall be paved with asphalt or concrete and designed in accordance with the standards of the off-street parking regulations of this title.

Response: As demonstrated by the Preliminary Plans (Exhibit A), parking areas are paved with asphalt concrete and are designed according to the standards of Chapter 18.145. See responses to the criteria of Chapter 18.145 below. This standard is met.

- (3) **Parking Lot Landscaping.** There shall be a five-foot landscaped buffer at the perimeter of all parking lot areas. Parking lots shall be designed and landscaped so as to break up large paved areas with landscaped islands, at a minimum of every 10 spaces.

Response: As demonstrated by the Preliminary Landscape Plan in the Preliminary Plans (Exhibit A), a 5-foot landscape buffer is provided around the perimeter of the parking areas. Parking spaces are separated by landscaping at a minimum of every 10 spaces and include parking lot trees. This standard is met.

18.45.070 Signs

Signs within the C-2 zone may be allowed consistent with Chapter 18.175 CMC.

Response: The subject site contains an existing sign welcoming incoming visitors to the City of Cornelius. As demonstrated by the Preliminary Plans (Exhibit A), the sign is planned to be retained as part of the planned improvements and this application does not include alterations to the existing sign. This standard is met.

Chapter 18.100 Site Design Review

(...)

18.100.030 Types of applications.

(...)

- (C) Design review Type III actions are those which are major and include:

(...)

- (2) General site plans for new development or substantial redevelopment.
- (3) New development, buildings or structures not part of a previously approved master plan.

Response: The planned improvements include a new multi-use single-story commercial building with a drive-through and a parking area with new driveway connections to adjacent streets. The planned improvements require a Type III Site Design Review. Additional phased improvements include a second multi-use commercial building to be approved through a separate Site Design Review permit at a later date.

18.100.040 Approval criteria.

In addition to the other requirements of the zoning code and other city ordinances, a project submitted for design review shall comply with the standards and criteria in subsections (A) and (B) of this section; all applications for a sign permit subject to the provisions of the sign code, Chapter 18.175 CMC, inclusive, shall comply with the rules and regulations of the committee adopted under the provisions of Division III of this title and other applicable provisions of the Cornelius Municipal Code.

- (A) Technical Standards. Where applicable, required off-site improvements shall be based on proportional analysis.
 - (1) Facilities and Services. The public and private facilities and services provided by the development are adequate as to location, size, design and timing of construction in order to serve the residents or establishments to be accommodated and meet city standards and the policies and requirements of the comprehensive plan. The service provider is presumed correct in the evidence which they submit;

Response: The planned improvements include public sidewalks and other frontage improvements along W Baseline Street and S 1st Avenue. As demonstrated by the Preliminary Plans (Exhibit A) and this narrative, these planned public facilities meet the location, size, and design standards of the Cornelius Municipal Code (CMC) and the Comprehensive Plan.

As demonstrated by the Preliminary Stormwater Report (Exhibit F), the planned stormwater facilities for Parcels 1 and 2 are sufficient to serve their respective parcels. A CWS Service Provider Letter is provided in Exhibit E. Required facilities and services are planned to be provided prior to construction of the new commercial building on Parcel 1 in order to adequately serve the building and its uses. This standard is met.

- (2) Traffic Generation. Based on anticipated vehicular and pedestrian traffic generation and the standards and policies of the comprehensive plan, adequate right-of-way and improvements to streets, pedestrian ways, bikeways, transitways and other ways are provided by the development in order to promote safety, reduce congestion, conserve energy and resources, and encourage transit use, bicycling and walking. Consideration shall be given to the need for constructing, widening and/or improving, to the standards of the comprehensive plan and this code, public streets, bicycle, pedestrian, and other ways in the area of the proposed development impacted by the proposed development. This shall include, but not be limited to, improvements to the right-of-way, such as installation of lighting, signalization, turn lanes, median and parking strips, traffic islands, paving, curbs and gutters, sidewalks, bikeways, transit facilities, street drainage facilities, traffic calming devices, and other facilities needed because of anticipated vehicular, transit, bicycle, and pedestrian traffic generation. Access and street design shall comply with the standards identified in Chapter 18.143 CMC, Transportation Facilities, and Chapter 5 of the adopted public works standards. Street trees shall be installed to the standards identified in Chapter 5 of the adopted public works standards. In lieu of actual construction of off-site improvements, the committee may accept written waivers of remonstrance to the formation of local improvement districts for the purpose of providing the needed off-site improvements or cash payment to the city in an amount equal to the estimated cost of said off-site improvements;

Response: As demonstrated by the Preliminary Plans (Exhibit A), the planned improvements include public frontage improvements along W Baseline Street and S 1st Avenue. Per comments

by City Engineer Terry Keys during the pre-application conference for this project (PAC-16-22, Exhibit G), a Transportation Impact Analysis is not required for this project because the City has existing information on the traffic impacts of the planned building that demonstrates that planned improvements can adequately serve anticipated vehicle, bicycle, and pedestrian traffic to the site. Improvements to the public rights-of-way, including sidewalks, landscape strips, street trees, accessways, and bike lanes, meet the standards of the CMC and the Comprehensive Plan.

Frontage improvements to S 1st Avenue include curbs, gutters, enhancements to existing sidewalks, and street trees in conformance with the City’s public works standards. Frontage improvements to W Baseline Street include curbs, gutters, sidewalks, a landscape strip, a bike lane, and a bus turnout with an expanded adjacent sidewalk. Street trees along W Baseline Street are not planned due to ODOT restrictions on trees adjacent to highways and conflicts with an electric utility easement along the landscape strip. The planned frontage improvements meet the standards of the CMC and the Comprehensive Plan. See responses to Section 18.143 for additional findings pertaining to traffic and transportation improvements. This standard is met as applicable.

- (3) **Dedication.** Adequate dedication or reservation of real property for public use, as well as easements and right of entry for construction, maintenance and future expansion of public facilities and services, shall be required to protect the public from any potentially deleterious effects resulting from the proposed use to fulfill the need for additional, improved services, whether on or off site, created by the proposed use, and to effect the implementation of the standards and policies of the comprehensive plan;

Response: As demonstrated by the Preliminary Plans (Exhibit A), the existing rights-of-way of S 1st Avenue and W Baseline Street meet the minimum widths for local and arterial streets, respectively. An 8-foot-wide public utility easement is provided around the site’s frontages for future expansion of public utilities. This standard is met.

- (4) **Internal Circulation.** There is a safe and efficient circulation pattern within the boundaries of the site. Consideration shall include the layout of the site with respect to the location, number, design and dimensions of vehicular, transit, and pedestrian access, exits, drives, walkways, bikeways, transit stops and facilities, building location and entrances, emergency equipment ways and other related on-site or off-site facilities so that there are adequate off-street parking and loading/unloading facilities provided in a safe, well designed and efficient manner. Consideration shall include the layout of parking, storage of all types of vehicles and trailers, shared parking lots and common driveways, garbage collection and storage points, as well as the surfacing, lighting, screening, landscaping, concealing and other treatment of the same. Developments shall provide a safe and reasonably direct pedestrian connection from the main entrance to the public right-of-way and/or the pedestrian system or both. The pedestrian connection shall be reasonably free of hazards from automobile traffic, so as to help encourage pedestrian and bicycle travel;

Response: As demonstrated by the Preliminary Plans (Exhibit A), internal circulation allows vehicles and pedestrians to navigate the site safely and efficiently. Drive aisle widths and access

points meet the standards of the CMC. Pedestrian access and crossings provide direct connections between public sidewalks and building entrances and are clearly delineated from parking areas. This standard is met.

- (5) **Maintenance of Private Facilities.** Adequate means are provided to ensure continued maintenance and necessary normal replacement of private common facilities and areas, drainage ditches, streets and other ways, structures, recreation facilities, landscaping, fill and excavation areas, screening and fencing, ground cover, garbage storage areas and other facilities not subject to periodic maintenance by the city or other public agency. Materials, including wastes, shall be stored and managed, and grounds shall be maintained in a manner that will not attract or aid in the propagation of insects or rodents or cause a health hazard;

Response: This criterion is understood.

- (6) **Public Facilities.** The structures and public facilities and services serving the site are designed and constructed in accordance with adopted codes and/or city standards at a level which will provide adequate fire protection and protection from crime and accident, as well as protection from hazardous conditions due to inadequate, substandard or ill-designed development;

Response: As demonstrated by the Preliminary Plans (Exhibit A), the planned improvements meet the criteria of the CMC and provide adequate protection from fire, crime, and other hazardous conditions. This standard is met.

- (7) **Security.** Adequate facilities shall be provided to prevent unauthorized entries to the property, facilitate the response of emergency personnel, and optimize fire protection for the building and its occupants. Adequate facilities may include, but not be limited to, the use of lighted house numbers and a project directory for multi-unit dwelling development;

Response: As demonstrated by the Preliminary Plans (Exhibit A), the planned parking area provides adequate entrances and area for maneuvering of emergency vehicles. A new fire hydrant is planned along W Baseline Street to provide access to fire suppression for the planned buildings.

- (8) **Grading.** The grading and contouring of the site takes place and site surface drainage and on-site storage of surface waters facilities are constructed so there is no adverse effect on neighboring properties, public rights-of-way or the public storm drainage system and that said site development work will take place in accordance with the city site development code;

Response: As demonstrated by the Preliminary Grading and Erosion and Sediment Control Plan in the Preliminary Plans (Exhibit A), grading and contouring required as part of the planned improvements is planned to be contained within the project site and will not impact adjacent properties, public rights-of-way, or public storm drainage. As demonstrated by the Preliminary Stormwater Report (Exhibit F), the planned underground stormwater facility provides adequate service to Parcel 1 and conveys stormwater to the public stormwater facilities in S 1st Avenue. The planned above-ground stormwater facility to

service Parcel 2 provides adequate treatment on-site for stormwater on that parcel. This standard is met.

- (9) **Utilities.** Prior to the development of a site, utilities shall be extended to serve the site or financially secured for extension to serve the site. Connection to city utilities shall be required prior to final inspection and occupancy. Electric, telephone, and other utility services to new development shall be located underground. New utilities for redeveloped parcels shall be located underground from the right-of-way to the redeveloped parcels;

Response: As demonstrated by the Preliminary Composite Utility Plan in the Preliminary Plans (Exhibit A), the planned improvements include utility extensions necessary to serve Parcel 1 and the planned new commercial building on that parcel. Utility improvements to Parcel 2 are planned to the degree necessary and will be fully improved in conjunction with an anticipated Site Design Review on Parcel 2 in the future. This standard is met as applicable.

- (10) **Accessibility.** Access and facilities for physically handicapped people are incorporated into the site and building design with particular attention to providing continuous, uninterrupted access routes;

Response: As demonstrated by the Preliminary Plans (Exhibit A), planned public improvements, pedestrian accessways, and parking areas are designed in accordance with ADA standards and will provide continuous and uninterrupted access to planned buildings for those with disabilities. This standard is met.

- (11) **Bicycle Lanes and Sidewalks.** Where street improvements on arterials and collectors are required as a condition of development approval, they shall include bicycle lanes or off-street multi-modal pathways, and sidewalks constructed in accordance with city standards.

Response: As demonstrated by the Preliminary Plans (Exhibit A), the subject property fronts S 1st Avenue and W Baseline Street. S 1st Avenue contains an existing sidewalk that will be fully improved as part of this project. Improvements to W Baseline Street include a sidewalk and a bike lane. The planned street improvements will conform with the requirements of the CMC and are addressed in further detail elsewhere in this narrative. This standard is met.

(B) **Nonresidential Design Standards.**

- (1) **Relation of Building to Site.** The proposed structures shall be related harmoniously to the terrain and to existing buildings which have a visual relationship to the proposed structure. Building height, bulk, lot area, coverage, setbacks, and scale should be particularly considered with regard to achieving compatible relationships. Screening, except in the industrial zone, exposed storage areas, utility buildings, machinery, service and truck loading areas, solid waste disposal cans, containers and other structures, and other accessory uses and structures, shall be adequately set back and screened. If a building is constructed, enlarged or altered to meet Type II thresholds and is located within 500 feet of a bus/transit stop, a main entrance door shall be placed on the street side of the bus/transit line and located as close as structurally possible to the bus/transit stop in compliance with this title;

Response: The subject property is located in the C-2 zoning district and adjacent properties are commercial in nature. The planned improvements include a new commercial building on Parcel 1 that meets the requirements of the CMC and is harmoniously related to other commercial buildings on adjacent properties. Screening is provided where necessary. As demonstrated by the elevations in the Preliminary Plans (Exhibit A), the planned improvements include a main entrance along the frontage of W Baseline Street within ±500 feet of the bus stop along that street. This standard is met.

- (2) **Trees and Vegetation.** The development has been designed to, where possible, incorporate and preserve existing trees or vegetation of significant size and species. Consideration shall be given to whether habitat, survival of the tree species, and aesthetics can best be achieved by preserving groves or areas of trees as opposed to only individual trees;

Response: As demonstrated by the Preliminary Landscape Plan in the Preliminary Plans (Exhibit A), the subject property has a wetland and vegetated corridor area along its southern boundary. This application plans to place this area in its own tract to protect the existing natural resources there and does not include any improvements in the natural resource area. The subject site does not contain any existing trees of significance. The planned improvements include street trees along S 1st Avenue. Street trees are not planned along W Baseline Street due to ODOT restrictions on trees along highways and conflicts with an electric utility line along the landscape strip. The planned improvements also include parking lot landscaping, islands, and parking lot trees. This standard is met.

- (3) **Historic Structures.** Consideration is given to the effect of the proposed development on historic buildings or features both on the site and within the immediate area;

Response: The subject property does not contain any historic structures. This standard is not applicable.

- (4) **Grading and contouring of the site shall take place with particular attention to minimizing the possible adverse effect of grading and contouring on the natural vegetation and physical appearance of the site;**

Response: The subject property contains an existing wetland and vegetated corridor along its southern boundary. As demonstrated by the Preliminary Grading and Erosion and Sediment Control Plan in the Preliminary Plans (Exhibit A), the planned improvements will not adversely affect this area and the natural resource area will be placed in a separate tract for preservation purposes. This standard is met.

- (5) **Landscaping.** The quality, location, size, and structural and aesthetic design of walls, fences, berms, traffic islands, median areas, hedges, screen planting and landscape areas are such that they serve their intended purposes and have no adverse effect on existing or contemplated abutting land uses;

Response: As demonstrated by the Preliminary Landscape Plan in the Preliminary Plans (Exhibit A), the planned improvements include landscaping that serves its intended purposes and does not adversely impact adjacent properties. Therefore, this standard is met.

-
- (6) **Lighting.** Adequate exterior lighting shall be provided to promote public safety, and shall be designed to avoid unnecessary glare upon other properties;

Response: As demonstrated by the Preliminary Site Lighting Plan in the Preliminary Plans (Exhibit A), the planned improvements include lighting on the planned building to illuminate entrances and adjacent pedestrian pathways. The planned lighting minimizes glare and will not impact adjacent properties. This standard is met.

- (7) **Solar Access.** In determining the appropriate relation of the building or structure to the site, the committee shall require that the building or structure be located on the site in a location and direction that will maintain, where feasible, solar access for adjacent properties and buildings or structures within the site.

Response: As demonstrated by the elevations in the Preliminary Plans (Exhibit A), the location of planned commercial structures will not impact solar access on adjacent properties or other planned buildings on the subject property. This standard is met.

18.100.050 Special conditions.

- (A) **Open Space, Parks and Recreation Areas.** Major residential developments, 20 units or more, shall include park and recreation areas, or both. In all multi-family projects, the required park and recreation area shall include a children's play area and play equipment for the use of residents and occupants of the multi-family project. The community development director shall have the power to approve plans for these recreation areas.

Response: Residential dwelling units are not included as part of the planned improvements. This standard is not applicable.

- (B) **Objectionable Uses.** Odor, dust, smoke, fumes, noise, glare, heat, and vibration from commercial and industrial uses, or both, which might create a nuisance or be offensive to other uses in the area or be incompatible with such other uses shall be adequately eliminated or controlled by authorized measures.

Response: The planned multi-use commercial building is intended for commercial uses (a dentist's office and drive-through coffee shop). The planned uses will not produce nuisances as described by this section. This standard is met.

18.100.060 Compliance with approvals.

- (A) **Time Limit on Approval.** Site design review approvals shall be void after two years unless a building permit has been issued and substantial construction pursuant thereto has taken place.
- (B) **Certificate of Occupancy.** In order to assure completion of the work in the manner and at the time approved, the premises shall not be used or occupied for the purposes set forth in the application until the city has completed a final inspection or issued a certificate of occupancy following completion of the work in substantial conformance to the approved plan. Prior to the final completion of all work, a certificate of occupancy or approval to occupy may be issued for a portion of the premises or conditioned upon further work being completed by a date certain.
- (C) **Revocation of Approval.** The community development director may, upon reasonable notice to the applicant and an opportunity for him to be heard,

revoke design review approval previously given and may revoke a certificate of occupancy for any of the following reasons:

- (1) Material misrepresentation of fact in the application or in testimony or evidence submitted, whether the misrepresentation is intentional or unintentional.
 - (2) Failure to complete work within the time and in the manner approved without obtaining an extension of time or modification of plans.
 - (3) Failure to maintain and use the property in accordance with the approved plans and conditions.
- (D) Violation. It shall be unlawful to use or occupy premises for which design review approval is required, or to perform work for which design review approval is required, without complying with the provisions of CMC 18.100.010. It shall be unlawful to willfully violate any term or condition of an approved design review.

Response: These standards are understood.

Chapter 18.143 Transportation Facilities

18.143.020 General provisions.

- (A) All transportation facilities shall be designed and improved in accordance with the standards of this code and the adopted Cornelius public works standards. In addition, when development abuts or impacts a transportation facility under the jurisdiction of one or more other governmental agencies, the city shall condition the development to obtain permits required by the other agencies.

Response: As demonstrated by the Preliminary Plans (Exhibit A), the planned improvements to W Baseline Street and S 1st Avenue meet the standards of this code and the Cornelius public works standards. W Baseline Street is also under the jurisdiction of ODOT. Improvements to W Baseline Street will meet the necessary ODOT standards and the applicable ODOT permits and/or approvals will be acquired in conjunction with these improvements. This standard is met as applicable.

- (B) In order to protect the public from potentially adverse impacts of the proposal, to fulfill an identified need for public services related to the development, or both, development shall provide traffic capacity, traffic safety, and transportation improvements in proportion to the identified impacts of the development.

Response: As demonstrated by the Preliminary Plans (Exhibit A), the planned improvements include traffic safety and transportation improvements in proportion with the anticipated traffic impacts of the new commercial use. Improvements include a two-way driveway on S 1st Avenue, a right-in/right-out driveway on W Baseline Street, a queueing lane for the planned drive-through, and drive aisles of adequate width for vehicles and emergency services. This standard is met.

- (C) For applications that meet the threshold criteria of CMC 18.143.030(B), Analysis Threshold, this analysis or limited elements thereof may be required.

Response: Per comments by City Engineer Terry Keys during the pre-application conference for this project (PAC-16-22, Exhibit G), the planned improvements do not require a Transportation Impact Analysis because the City has adequate information to determine

the adequacy of the planned transportation impacts and improvements. This standard is not applicable.

- (D) The decision-making authority may impose development conditions of approval per this title. Conditions of approval may be based on the traffic impact analysis.

Response: This standard is understood.

- (E) Dedication of rights-of-way shall be determined by the decision-making authority.

Response: As demonstrated by the Existing Conditions Plan in the Preliminary Plans (Exhibit A), the existing rights-of-way of S 1st Avenue and W Baseline Street are of adequate width and dedication of rights-of-way are not anticipated with the planned improvements. It is understood that additional dedication may be required by the decision-making authority.

- (F) Traffic calming may be approved or required by the decision-making authority in a design of the proposed and/or existing streets within the area of influence or any additional locations identified by the city engineer. Traffic calming measures shall be designed to city standards.

Response: This standard is understood and will be met as applicable.

- (G) Intersection performance shall be determined using the Highway Capacity Manual, Sixth Edition, published by the Transportation Research Board. The city engineer may approve a different intersection analysis method prior to use when the different method can be justified. Terms used in this subsection are defined in the Highway Capacity Manual, Sixth Edition.

Response: This standard is understood and will be met as applicable.

- (H) City street intersections shall maintain a level of service (LOS) of “D” during the p.m. peak hour of the day. An LOS of “E” may be accepted for local street approaches or driveway access points that intersect with collector or arterial streets, if these intersections are found to operate safely.

Response: This standard is understood and will be met by the planned improvements.

18.143.030 Traffic impact analysis.

For each development proposal that exceeds the analysis threshold of subsection (B) of this section, the application for land use or design review approval shall include a traffic impact analysis as required by this code. The traffic impact analysis shall be based on the type and intensity of the proposed land use change or development and its estimated level of impact to the existing and future local and regional transportation systems.

Response: Per comments by City Engineer Terry Keyes during the pre-application conference (PRE-16-22, Exhibit G), the City is aware that the current transportation facilities adjacent to the site are sufficient to serve the anticipated traffic impacts from the planned improvements. Therefore, a Traffic Impact Analysis (TIA) is not required as part of this application.

18.143.040 Street design cross-sections per transportation system plan.

Street cross-sections include the right-of-way, paved section, sidewalk and planter strip widths. The functional classification of a street as designated in the transportation system plan shall determine its design and width. Identification of functional classifications for streets in the city limits is found in the adopted Cornelius transportation system plan. Street design standards,

which are based on functional classification and use, are found in the adopted Cornelius public works standards. Full street connections shall be provided at intervals consistent with the adopted Cornelius public works standards for the identified street classification, except as modified by Chapter 18.115 CMC, or where prevented by topography, barriers such as railroads or freeways, or environmental constraints such as major streams and rivers.

Response: As demonstrated by the Preliminary Plans (Exhibit A), the planned street improvements will provide facilities that comply with street cross-section requirements as stated by the Cornelius public works standards and ODOT. Therefore, this standard is met.

18.143.050 Access standards.

Access standards establish requirements and regulations for safe and efficient vehicle access to and from a site and enhance general circulation within a site.

- (A) Access Spacing. Access spacing shall be designed in conformance with the adopted Cornelius public works standards.
 - (1) Access spacing for all state facilities shall be coordinated with the Oregon Department of Transportation (ODOT).

Response: As demonstrated by the Preliminary Plans (Exhibit A), the planned improvements include a two-way driveway entrance on S 1st Avenue and a right-in, right-out entrance on W Baseline Street. The planned access points meet the access standards of Cornelius public works and ODOT, respectively. Additional permits and documentation required by ODOT will be acquired as necessary. This standard is met as applicable.

- (B) An access report shall be submitted with all new development and/or redevelopment proposals that demonstrates the street/driveway is safe as designed and meets adequate stacking, site distance, deceleration distance, on-site circulation and deceleration requirements as set by the city, American Association of State Highway and Transportation Officials (AASHTO), and relevant agencies.

Response: The Preliminary Plans (Exhibit A) demonstrate that the planned access points meet the requirements listed in this section. W Baseline Street is under the jurisdiction of ODOT. The necessary ODOT documentation and permits, including those pertaining to access, will be provided in conjunction with this application. This standard is met as applicable.

- (C) Driveway/Access Points. The location and number of driveways or access points have a direct effect on safe and efficient traffic flow. The following access management standards shall apply toward new driveways:
 - (1) Driveway spacing shall be designed in accordance with adopted public works standards. In some cases, driveway setbacks may be greater than the standard depending upon the influence area, as determined by city engineer review of a traffic impact report submitted by the applicant's traffic engineer. If the subject property has less than 150 feet of street frontage, the applicant shall first investigate a shared access as an option. If a shared access is not possible, the driveway shall be placed as far from the intersection as possible.

Response: As demonstrated by the Preliminary Plans (Exhibit A), the planned improvements include a two-way driveway entrance on S 1st Avenue and a right-in, right-out entrance on W Baseline Street. Driveways are designed to meet Cornelius public works and ODOT spacing standards, respectively. The planned access onto W

Baseline Street is planned as far as possible from the intersection of S 1st Avenue and W Baseline Street and is planned to be shared with the adjacent commercial property to the east. This standard is met.

- (2) Based on the applicants' proposal and its compliance with the comprehensive plan, transportation system plan and the development and zoning code, the city shall require the closing or consolidation of existing driveways or other vehicle access points, the recording of reciprocal access easements (i.e., for shared driveways), and installation of traffic control devices or other measures as a condition of approval to mitigate the impacts of the development.

Response: The subject property currently contains two curb cuts for driveways along S 1st Avenue. As demonstrated by the Preliminary Plans (Exhibit A), the northernmost curb cut is planned to be removed as part of the planned improvements in order to meet the access and driveway spacing standards of this section. The southernmost curb cut is planned to be utilized as a driveway entrance and meets the standards of this section. The access onto W Baseline Street is intended to be shared with the adjacent commercial property to the east. It is understood that a shared access easement for this access may be required. This standard is met as applicable.

- (3) New developments shall provide cross-over easements to ensure potential shared driveway access points where existing conditions (i.e., surrounding land uses, lot configurations, physical characteristics, etc.) warrant consideration.

Response: As demonstrated by the Preliminary Plans (Exhibit A), the planned improvements include a new commercial building on Parcel 1 and parking areas on Parcels 1 and 2 to serve the planned building and a future commercial building on Parcel 2. Crossover access easements are planned across Parcels 1 and 2 to provide shared access and circulation between the two parcels with the understanding that the parking area will be shared upon construction of the future building on Parcel 2. This standard is met as applicable.

- (4) Access to arterials shall only be from public streets. When a site that has private access onto a principal arterial is redeveloped, the private access shall be eliminated if alternate access exists or can be developed to the site.

Response: The subject property has frontage on W Baseline Street, an arterial street per the City of Cornelius TSP. As demonstrated by the Preliminary Plans (Exhibit A), the planned improvements include a right-in/right-out access onto W Baseline Street. This access is necessary in order to provide secondary access to the site for circulation and emergency vehicles. This access is located as far from the intersection of S 1st Avenue and W Baseline Street as possible and is intended to be shared with adjacent commercial property to the east of the site. A shared access easement will be provided between Parcel 2 and the adjacent property to the east to provide shared access. The necessary ODOT documentation and permits will be acquired and provided to the City as part of this application. This standard is met as applicable.

- (5) Direct access to a collector street shall only be considered if there is no alternative way to access the site. If direct access is permitted by the city, the applicant shall be required to mitigate for any safety or

neighborhood traffic management impacts deemed applicable by the city engineer. In no case shall the design of driveways, drive aisles or service drives require or encourage the backward movement or other maneuvering of a vehicle within a street, except for single-family and duplex residences.

Response: The subject property does not have frontage on a collector street. This standard is not applicable.

- (6) Proposed shared-use paths shall be located to provide access to existing or planned commercial services and other neighborhood facilities, such as schools, shopping areas and park and transit facilities. To the greatest extent possible, access shall be reasonably direct, providing a route or routes that do not deviate unnecessarily from a straight line or that do not involve a significant amount of out-of-direction travel.

Response: As demonstrated by the Preliminary Plans (Exhibit A), the planned improvements include pedestrian pathways connecting planned public sidewalks along W Baseline Street and S 1st Avenue to commercial building entrances. This standard is met.

18.143.060 Transit supportive amenities.

- (A) New commercial, industrial and institutional buildings developed on sites adjacent to major transit stops shall provide transit-related improvements. Major transit stops are identified as part of the regional transit system or as otherwise defined in Chapter 18.195 CMC. Properties are considered “at” a major transit stop when they are within 200 feet of the stop. A proposed development that is adjacent to or includes an existing or planned major transit stop will be required to plan for access to the transit stop and provide for transit improvements, in consultation with TriMet and consistent with an agency adopted or approved plan at the time of development. Requirements apply where the subject parcel(s) or portions thereof are within 200 feet of a major transit stop. Development requirements and improvements may include the following:
 - (1) Intersection or mid-block traffic management improvements to allow for pedestrian crossings at major transit stops.
 - (2) Building placement within 20 feet of the transit stop, a transit street or an intersection street, or a pedestrian plaza at the stop or a street intersections.
 - (3) Transit passenger landing pads accessible to disabled persons to transit agency standards.
 - (4) An easement or dedication for a passenger shelter and an underground utility connection to a major transit stop if requested by TriMet.
 - (5) Lighting to TriMet standards.
 - (6) Intersection and mid-block traffic management improvements as needed and practicable to enable marked crossings at major transit stops.

Response: The subject property is adjacent to a bus stop on W Baseline Street that is considered a Minor Bus Stop according to the City of Cornelius TSP. Therefore, this standard is not applicable.

-
- (B) For an existing use or proposed use on a site located within one-quarter mile from a bus stop where at least 10 off-street parking spaces are required, the applicant may apply for a reduction in the number of required spaces by 10 percent through the provision of transit supportive amenities, subject to city approval.

Response: The subject property is within one-quarter mile of a bus stop. It is understood that parking spaces can be reduced as part of the planned improvements.

18.143.070 Intelligent transportation systems.

Intelligent transportation systems (ITS) manage and enhance operational performance through advanced technologies and management techniques to help relieve congestion, promote safety and provide suitable transportation strategies.

In order to provide for efficient installation of future intelligent transportation systems (ITS), all roadway improvement projects, including private development with frontage improvements, shall install three-inch conduit to support local interconnect infrastructure. The location, design and type of conduit shall be approved by the city engineer.

Response: This standard is understood, and conduit can be provided as necessary.

Chapter 18.145 Off-Street Parking and Loading

18.145.010 General provisions.

- (A) The provision and maintenance of off-street parking and loading spaces are continuing obligations of the property owner. No building or other permit shall be issued until plans are presented that show property that is and will remain available for exclusive use as off-street parking and loading space as required by this title. The subsequent use of property for which the building permit is issued shall be conditional upon the unqualified continuance and availability of the amount of parking and loading space required for the specific use. Use of property in violation of the off-street parking and loading requirements located herein shall be a violation of this code. Should the owner or occupant of a lot or building change the use to which the lot or building is put, thereby increasing off-street parking or loading requirements, it shall be a violation of this code to begin or maintain the altered use until the required increase in off-street parking or loading is provided, except as provided in the central mixed use (CMU) and corridor commercial (CC) zoning districts (see CMC 18.145.020(C)).

Response: This criterion is understood and will be met as applicable.

- (B) Unless otherwise provided, required parking and loading spaces shall not be located in a required yard.

Response: As demonstrated by the Preliminary Plans (Exhibit A), parking spaces included with the planned improvements are located outside of the 5-foot setback area required for parking within the C-2 zoning district. This standard is met.

- (C) Owners of two or more uses, structures, or parcels of land may agree to utilize jointly the same parking and loading spaces when the hours of operation do not overlap; provided, that satisfactory legal evidence is presented to the community development director in the form of deeds, leases, or contracts to establish the joint use.

Response: This application includes a new multi-use commercial building that will contain two commercial uses (a dentist's office and a drive-through coffee shop). The planned uses will share the planned parking area and adequate parking is provided to serve both uses.

Additionally, this application includes a partition to create a separate parcel intended for future commercial development to be reviewed under a separate Site Design Review application at a later date. Parking areas and drive aisles are planned to be shared by the two parcels and crossover access easements will be provided to grant shared use between the two parcels. This standard is met.

- (D) A plan drawn to scale, indicating how the off-street parking and loading requirement is to be fulfilled, shall accompany the request for a building permit, site plan review, or certificate of occupancy. The plan shall show all those elements necessary to indicate that these requirements are being fulfilled and shall include but not be limited to:
- (1) Delineation of individual parking and loading spaces and their dimensions;
 - (2) Circulation area necessary to serve spaces;
 - (3) Access to streets, alleys and properties to be served;
 - (4) Curb cuts;
 - (5) Location and dimensions of all landscaping, including the type and size of plant material to be used, as well as any other nonliving landscape material incorporated into the overall plan, excluding single- and two-family residences and multi-family uses with not more than four units in the core residential zone; and
 - (6) Specifications as to signs and bumper guards, excluding single- and two-family residences and multi-family uses with not more than four units in the core residential zone.

Response: The planned parking lot improvements shown in the Preliminary Plans (Exhibit A) include the required items listed in this section. It is understood that the items in this section will be required in the construction documents when building permit applications are submitted.

- (E) Requirements for types of buildings and uses not specifically listed herein shall be determined by the community development director, based upon the requirements of comparable uses listed.

Response: This standard is understood.

18.145.020 Off-street parking.

- (A) At the time of erection of a new structure or at the time of enlargement or change in use of an existing structure within any zone in the city, off-street parking spaces shall be provided in accordance with CMC 18.145.030. If parking space has been provided in connection with an existing use or is added to an existing use, the parking space shall not be eliminated if elimination would result in less space than is specified in the standards of this section when applied to the entire use. In cases of enlargement of a building or use of land existing on the effective date of the ordinance codified in this title, the number of parking spaces required shall be based only on floor area or capacity of such enlargement.

Response: The Climate-Friendly and Equitable Communities (CFEC) rules adopted by the Oregon Land Conservation and Development Commission (LCDC) in July 2022 eliminated the minimum parking standards for uses in certain urban areas. The subject property is within the Metro service boundary and is adjacent to a high-service bus stop on W Baseline

Street (a frequent transit corridor). Therefore, the minimum parking standards of this section are not applicable to this project.

18.145.030 Required off-street parking spaces.

- (A) Off-street parking shall be provided based on the primary use of the site according to the following standards and regardless of the parking zone in which the use is located (see Map 1 following this chapter).

Table 1 Minimum and Maximum Required Off-Street Vehicle and Bicycle Parking Requirements (unless otherwise noted, standard is per 1,000 sf of gross floor area)		
Land Use	Maximum Parking Standards (spaces/square feet)	Minimum Bicycle Parking Standards
	Zone A	
OFFICE	3.4/1,000	0.5/1,000
COMMERCIAL		
Eating and Drinking Establishments	Fast food: 12.4/1,000	All: 1.0/1,000

Response: The Climate-Friendly and Equitable Communities (CFEC) rules adopted by the Oregon Land Conservation and Development Commission (LCDC) in July 2022 eliminated the minimum parking standards for uses in certain urban areas. The subject property is within the Metro service boundary and is adjacent to a high-service bus stop on W Baseline Street (a frequent transit corridor). Therefore, the minimum parking standards of this section are not applicable to this project. Additional information on how the project abides by CFEC guidelines can be found in the Executive Summary above.

The planned improvements include a new commercial building with a dentist’s office and a drive-through coffee shop. The dentist’s office will occupy ±4,800 square feet and the coffee shop will occupy ±2,330 square feet. Shared parking is planned to be provided for the planned use on Parcel 1 and the future use(s) on Parcel 2 and parking is planned on both parcels as part of this project. Table 1 below demonstrates the maximum vehicle parking and minimum bicycle parking standards for the planned uses on Parcel 1. Table 2 demonstrates a conservative estimation of maximum parking for the anticipated future use on Parcel 2 (sales-oriented retail). This use was selected for purposes of estimating maximum parking allowed for the shared parking area; parking will be reevaluated upon submission of the future Site Design Review application for the commercial building on Parcel 2.

Table 1					
Planned Use	Square Feet of Use	Maximum Parking Standard	Maximum Parking Permitted	Required Bicycle Parking	Minimum Spaces Required
Office	±4,800	3.4/1,000	16 spaces	0.5 spaces / 1,000 square feet	3 spaces
Eating and Drinking Establishments	±2,330	12.4/1,000	28 spaces	1.0 spaces / 1,000 square feet	3 spaces
Maximum Vehicle Parking Permitted			44 spaces	Minimum Bicycle Parking Required	6 spaces
Planned Vehicle Parking (Shared Across Both Parcels)			63 spaces	Bicycle Parking Provided (Parcel 1)	6 spaces

Table 2				
Anticipated Use	Square Feet of Use	Maximum Parking Standard	Maximum Parking Permitted for Parcel 2 Use	Maximum Parking Permitted Across Both Parcels
Sales-Oriented Retail	±10,900	5.1/1,000	55 spaces	99 spaces

As demonstrated by Tables 1 and 2 above, the planned parking spaces in the shared parking area (±63 spaces) meet the maximum parking standard of the planned uses on Parcel 1 and anticipated future use(s) on Parcel 2. Additional parking spaces, landscaping, and trees will be provided as part of future improvements on Parcel 2 (shown as “Phase 2” on the Preliminary Site Improvements Plan in Exhibit A). Parking spaces for the shared parking area will be further evaluated with the Site Design Review application for the future use on Parcel 2. Therefore, the maximum parking standard for the shared parking area is met as applicable.

The planned commercial building on Parcel 1 and its uses require a minimum of ±6 bicycle parking spaces. As shown on the Preliminary Plans, the planned improvements include three bicycle parking racks providing greater than ±6 bicycle parking spaces. This standard is met.

All uses providing drive-in service as defined by this title shall provide on the same site a reservoir for inbound vehicles as follows:

Land Use	Reservoir Requirement
Drive-In Restaurants	10 spaces/service window

Response: The planned improvements include a new drive-through use in a new commercial building on Parcel 1. As demonstrated by the Preliminary Plans (Exhibit A), the planned improvements include a parking reservoir providing a queuing area for ±10 vehicles. Therefore, this standard is met.

18.145.040 Off-street loading.

(A) Buildings and structures to be built or substantially altered which receive and distribute material or merchandise by truck shall provide and maintain off-street loading space as follows:

Table 2 Off-Street Loading Requirements	
Land Use	Loading Space Requirement
Commercial	
Floor Area	
Under 5,000 sq ft	0
5,000 to 25,000 sq ft	1

Table 3 Minimum Loading Berth Dimensions		
Land Use	Length – Linear Feet	Width – Linear Feet
All uses except wholesale and industrial	35	12

Response: The planned improvements include a new commercial building on Parcel 1 containing two uses (a dentist’s office and a drive-through coffee shop). The dentist’s office will occupy ±4,800 square feet and is not anticipated to receive and distribute material or merchandise. The coffee shop will occupy ±2,330 square feet and therefore does not require a loading space.

As demonstrated by the Preliminary Plans (Exhibit A), a loading berth for the future building on Parcel 2 is planned as part of the parking lot improvements in anticipation of a building greater than ±5,000 square feet. The planned loading berth meets the dimensional requirements of this section. Therefore, the standards of this section are met as applicable.

(...)

(C) Merchandise, Materials or Supplies. Buildings or structures to be built or substantially altered which receive and distribute material or merchandise by truck shall provide and maintain off-street loading berths in sufficient numbers and size to adequately handle the needs of the particular use. If loading space has been provided in connection with an existing use or is added to an existing use, the loading space shall not be eliminated if

elimination would result in less space than is required to adequately handle the needs of the particular use.

Response: As discussed in the response to subsection (A) above, the planned commercial building on Parcel 1 does not meet the threshold for a loading berth. A loading berth will be provided on Parcel 2 in anticipation of future uses and will be reassessed when a Site Design Review application is submitted for that building at a later date. This standard is met as applicable.

(D) Any area to be used for the maneuvering of delivery vehicles and the unloading or loading of materials shall be separated from designated off-street parking areas and appropriately designed to prevent the encroachment of delivery vehicles into off-street parking areas or into a public street.

Response: As demonstrated by the Preliminary Plans (Exhibit A), the planned loading area on Parcel 2 prevents the backing and maneuvering of delivery vehicles within the parking area and public right-of-way. The loading area will be separated from off-street parking areas. This standard is met.

(E) The facilities review committee may modify the off-street loading requirements as they apply to any individual case only for good cause shown, and it shall set reasonable safeguards and conditions to ensure that any such modification conforms to the intent of this title. Modification may be granted if it is demonstrated to the satisfaction of the committee that loading operations of the use or structure in question will not interfere with pedestrian or vehicular traffic on a public street.

Response: This standard is understood.

(...)

18.145.050 Design and maintenance standards for off-street parking and loading facilities.

(A) Except as otherwise defined in this code, “one standard parking space” means a minimum of a parking stall of nine feet in width and 20 feet in length. To accommodate compact cars more efficiently, up to 25 percent of the available parking spaces may have a minimum dimension of eight feet in width and 16 feet in length, so long as they are identified as compact car stalls and are not readily accessible to large cars.

Response: As demonstrated by the Preliminary Plans (Exhibit A), the planned parking spaces meet the dimensional requirements of this section. This standard is met.

(B) Excluding detached single-unit dwellings and middle housing residences, groups of two or more parking spaces shall be served by a service drive so that no backing movements or other maneuvering within a street or other public right-of-way would be required.

Response: As demonstrated by the Preliminary Plans (Exhibit A), the planned parking area includes service drives that prevent the backing and maneuvering of vehicles within the public right of way. This standard is met.

(C) Service drives shall be designed and constructed to facilitate the flow of traffic, provide maximum safety of traffic access and egress consistent with CMC 18.150.070, and maximum safety of pedestrians and vehicular traffic on the site.

Response: As demonstrated by the Preliminary Plans (Exhibit A), the service drives included with parking lot improvements are planned to meet the standards of this section. This standard is met.

(D) Each parking and/or loading space shall be accessible from a street and the access shall be of a width and location as described in this section.

Response: As demonstrated by the Preliminary Plans (Exhibit A), the planned parking spaces include access to public streets that meet the requirements of this section. This standard is met.

(E) Parking space configuration, stall and access aisles shall be of sufficient width for all vehicles turning and maneuvering.

Response: As demonstrated by the Preliminary Plans (Exhibit A), the planned parking area provides sufficient turning and maneuvering areas for all parking spaces. This standard is met.

(F) Except for detached, single-unit dwellings and middle housing residences, any area intended to be used to meet the off-street parking requirements as contained in this title shall have all parking spaces clearly marked using a permanent paint. All interior drives and access aisles shall be clearly marked and signed to show direction of flow and maintain vehicular and pedestrian safety.

Response: Parking spaces and affiliated improvements are planned to be painted and marked in accordance with this section. This standard is met.

(G) Except for detached, single-unit dwellings and middle housing residences, all areas used for the parking and/or storage and/or maneuvering of any vehicle, boat and/or trailer shall be improved with asphalt or concrete surfaces according to the same standards required for the construction and acceptance of city streets. Off-street parking spaces for residential development with not more than four units in the core residential zone shall be improved with an asphalt or concrete surface to specification as approved by the building official.

Response: As demonstrated by the Preliminary Plans (Exhibit A), the planned parking area is planned to be paved with asphalt concrete. This standard is met.

(H) Parking spaces along the outer boundaries of a parking lot or adjacent to interior landscaped areas or sidewalks shall be provided with a wheel stop at least four inches high located three feet back from the front of the parking stall. The facilities and design review committee or the planning commission may approve parking spaces without wheel stops, provided the abutting sidewalk is increased by three feet in width and/or the appropriate landscaping is planted where the bumper would overhang.

Response: As demonstrated by the Preliminary Plans (Exhibit A), wheel stops are provided for parking spaces adjacent to sidewalks that are not increased by three feet in width and where landscaping is not planned in vehicle overhang areas. This standard is met.

(I) Off-street parking and loading areas shall be drained in accordance with specifications approved by the city engineer.

Response: As demonstrated by the Preliminary Stormwater Report (Exhibit F), off street parking areas on Parcel 1 will be drained to an underground stormwater facility and routed to storm mains in S 1st Avenue. Stormwater from parking areas on Parcel 2 will be routed to an above-ground treatment facility on that parcel with an outfall in the vegetated corridor

in Tract A at the south of the site. The facilities will provide adequate stormwater treatment for the parking areas on each parcel and meet the Cornelius public works standards. This standard is met.

- (J) Artificial lighting on all off-street parking facilities shall be designed to deflect all light away from surrounding residences and so as not to create a hazard to the public use of any road or street.

Response: As demonstrated by the Preliminary Site Lighting Plan in the Preliminary Plans (Exhibit A), the lighting for the planned building will be directed downward to avoid glare to adjacent properties. This standard is met.

- (K) Signs which are provided on parking lots for the purpose of meeting this section shall be as prescribed by the building official.

Response: This standard is understood and will be met.

- (L) All parking lots shall be kept clean and in good repair at all times. Breaks in paved surfaces shall be repaired promptly, and broken or splintered wheel stops shall be replaced so that their function will not be impaired.

Response: This standard is understood and will be met.

- (M) Bicycle parking spaces shall be conveniently located with respect to the street, bicycle path/lane and building entrance. Bicycle parking spaces shall not conflict with off-street vehicle parking spaces and drive aisles. There shall be at least 36 inches of clearance between parked bicycles and other obstructions or buildings.

- (1) Short-Term Bicycle Parking. Short-term bicycle parking shall be provided to encourage shoppers, customers, and other visitors to use bicycles by providing a convenient and readily accessible place to park bicycles.

- (a) Short-term bicycle facilities shall be in the form of either a lockable enclosure or a stationary rack, either covered or uncovered, to which the bicycle can be locked.

- (b) Short-term bicycle facilities shall be located within 30 feet of the main entrance to the building, in a location that is easily accessible for bicycles.

(...)

Response: As demonstrated by the Preliminary Plans (Exhibit A), the planned improvements include bicycle parking to be provided in the form of a stationary rack within 30 feet of the building's entrance. The planned improvements include three bicycle parking racks providing greater than ±6 spaces as discussed in responses to Section 18.145.030. This standard is met.

- (2) Long-Term Bicycle Parking. Long-term bicycle parking provides employees, students, residents, commuters, and others who generally stay at a site for several hours a weather-protected place to park bicycles.

- (a) A minimum of 50 percent of the bicycle parking spaces shall be provided as long-term bicycle parking in any of the following situations:

(...)

-
- (ii) If more than four bicycle parking spaces are required.

Response: As demonstrated by the response to CMC Section 18.145030(A) above, the planned commercial building on Parcel 1 requires ± 6 bicycle parking spaces. Therefore, ± 50 percent of these spaces (or ± 3 spaces) are required to be long-term parking.

As demonstrated by the Preliminary Plans (Exhibit A), the planned improvements include bicycle parking adjacent to the commercial building on Parcel 1 and the planned future building on Parcel 2. Parking covering can be assessed at the time of future building permit review. This standard is met as applicable.

- (b) Secured bicycle parking facilities shall be provided on site; facilities can include a bicycle storage room, bicycle lockers, covered racks, or other secure storage space inside or outside of the building. Long-term bicycle parking facilities shall be located not more than 75 feet from a building entrance.

Response: As demonstrated by the Preliminary Plans (Exhibit A), bicycle parking is provided adjacent to the planned commercial building. Parking covering and security can be assessed at the time of future building permit review. This standard is met as applicable. This standard is met as applicable.

18.145.060 Landscaping Required

(...)

(B) **Minimum Requirements.** All areas used for the display and/or parking of any and all types of vehicles, trailers, boats or heavy construction equipment, whether such vehicles traverse the property as a function of the primary use, hereinafter referred to as “other vehicular uses,” shall conform to the minimum landscaping requirements provided in this section. Activities that are of a drive-in nature such as, but not limited to, filling stations, grocery and dairy stores, banks, restaurants, and the like shall conform to the minimum landscaping requirements also. The following areas are not required to meet the landscaping standards:

- (1) Where all of the parking or other vehicular uses are located under, on or within buildings; and
- (2) Parking areas serving single- and two-family uses and multi-family uses with not more than four units in the core residential zone as normally such residential areas shall not be required to meet.

Response: As demonstrated by the Preliminary Landscape Plan in the Preliminary Plans (Exhibit A), the planned parking area includes landscaping in accordance with the requirements of this section. This project does not include parking under, on, or within buildings and does not include residential uses. The requirements are met.

(C) **Installation.** All landscaping shall be installed in a sound workmanship-like manner and according to accepted good planting procedures with the quality of plant materials as hereinafter described. All elements of landscaping exclusive of plant material except hedges shall be installed so as to meet all other applicable ordinances and code requirements. Landscaped areas shall require protection from vehicular encroachment as herein provided in CMC 18.145.050(H). The community development director or the building official shall inspect all landscaping and no certificates of occupancy or similar

authorization will be issued unless the landscaping meets the requirements herein provided.

Response: This standard is understood and will be met.

- (D) Maintenance. The owner, tenant and their agent, if any, shall be jointly and severally responsible for the maintenance of all landscaping which shall be maintained in good condition so as to present a healthy, neat and orderly appearance and shall be kept free from refuse and debris. All plant growth in interior landscaped areas shall be controlled by pruning, trimming or otherwise so that:
- (1) It will not interfere with the maintenance or repair of any public utility;
 - (2) It will not restrict pedestrian or vehicular access; and
 - (3) It will not constitute a traffic hazard because of reduced visibility.

Response: This standard is understood and will be met.

18.145.070 Parking lot design standards.

- (A) Required Landscaping Adjacent to Public Right-of-Way. A strip of land at least five feet in width located between the abutting right-of-way and the off-street parking area or vehicle use area which is exposed to an abutting right-of-way, except in required vision clearance areas as provided in CMC 18.150.070.

Response: As demonstrated by the Preliminary Landscape Plan in the Preliminary Plans (Exhibit A), a landscape strip at least ±5 feet in width is provided between the public right-of-way and the planned off-street parking area. This standard is met.

- (B) Perimeter Landscaping Relating to Abutting Properties. On the site of a building or structure or open lot use providing an off-street parking area or other vehicular use area, where such areas will not be entirely screened visually by an intervening building or structure from abutting property, a five-foot landscaped strip shall be between the common lot line and the off-street parking area or other vehicular use area exposed to abutting property.

Response: This application includes a partition that will divide the subject property. The subject property's easterly property line, which abuts an adjacent commercial property, will be located on Parcel 2. Parcel 1 is planned to be improved with a new commercial building and affiliated landscaping. Parcel 2 is planned to be improved at a later date. As demonstrated by the Preliminary Landscape Plan in the Preliminary Plans (Exhibit A), a landscape strip meeting the requirements of this section is provided between the parking improvements planned on Parcel 2 and the adjacent commercial property. It is understood that additional landscaping on Parcel 2 may be required upon its future development. This standard is met as applicable.

- (C) Where the boundary of a parking lot in a nonresidential zone adjoins a residential district, a 10-foot landscaped strip shall be provided along the entire length abutting the residential zone, and shall be landscaped with evergreen plant material and maintained at a minimum height of 36 inches.

Response: The subject property is not adjacent to a residential zone. This criterion is not applicable.

- (D) Parking Area Interior Landscaping. Landscaped islands shall be provided a minimum of every 10 parking spaces with a depth equivalent to the depth of

the adjacent parking spaces and a minimum width of six feet to break up large expanses of pavement, improve the appearance and climate of the site, improve safety, and delineate pedestrian walkways and traffic lanes. Except for industrial development within industrial zones, the following interior landscaping shall be met:

- (1) **Sight Distance for Landscaping at Points of Access.** When an accessway intersects a public right-of-way or when the subject property abuts the intersection of two or more public rights-of-way, all landscaping within vision clearance areas pursuant to CMC 18.150.070 shall provide unobstructed cross-visibility at a level between three feet and 10 feet above the curb line; provided however, visibility areas shall be allowed, provided they are so located so as not to create a traffic hazard. Landscaping except required grass or ground cover shall not be located closer than three feet from the edge of any accessway pavement.

Response: As demonstrated by the Preliminary Landscape Plan in the Preliminary Plans (Exhibit A), the planned parking area includes landscape islands that are a minimum ±6 feet wide every 10 spaces throughout the parking area. Landscaping within required vision clearance areas is planned to meet the requirements of this section. This standard is met.

- (2) **Parking lots that are more than three acres in size shall provide street features along major drive aisles.** These features shall include at a minimum curbs, sidewalks and street trees and/or planter strips or both.

Response: The planned parking area is less than ±3 acres. This standard is not applicable.

- (3) **Access to and from parking spaces/areas shall not permit backing onto a public street and/or a public vehicle travel lane or both, except for single-family or duplex dwellings and multi-family uses with not more than four units in the core residential zone.**

Response: As demonstrated by the Preliminary Plans (Exhibit A), the planned parking area provides sufficient access and drive aisles to prevent maneuvering within the public rights-of-way adjacent to the subject property. Therefore, this standard is met.

18.145.080 Drainage of off-street parking and loading facilities.

Off-street parking and loading facilities shall be drained to avoid flow of water across public sidewalks.

Response: As demonstrated by the Preliminary Plans (Exhibit A), the parking area on Parcel 1 is planned to be served by an underground stormwater treatment system that will convey stormwater to public facilities within S 1st Avenue. Parcel 2 will be served by an above-ground stormwater treatment facility in the southern portion of the parcel. As demonstrated by the Preliminary Grading & Sediment & Erosion Control Plan, the planned grading and stormwater facilities will route drainage away from public sidewalks. Therefore, this standard is met.

18.145.090 Security required.

- (A) **Completion Time for Parking Lots.** Required parking spaces shall be improved and available for use before the final inspection. An extension of time may be granted by the community development director, provided a security equal to 150 percent of the cost of the parking lot is posted with the city of Cornelius and the parking space is not required for immediate use. If

the parking improvements are not completed within six months, the city shall have access to the security to complete the installation and/or revoke occupancy. Upon completion of the installation, any portion of the remaining security shall be returned to the owner. Costs in excess of the posted security shall be assessed against the property and the city shall thereupon have a valid lien against the property, which shall become due and payable.

Response: This standard is understood and will be met.

Chapter 18.150 Special Use Regulations

(...)

18.150.070 Clear vision zones.

Except in the central mixed use (CMU) zoning district, a clear vision zone shall be maintained on the corners of all property adjacent to the intersection of two streets, a street and a railroad, or a driveway providing vehicular access to a public street.

- (A) The clear vision zone is defined as the triangular area beginning at the intersection of the projected curb lines, and extending 15 feet along the leg of each intersection. No fence, berm, wall, hedge or other planting or structure shall be placed within the clear vision zone that would impede visibility between a height of 30 inches and 10 feet as measured from the top of curb, or in the absence of a curb, from the established street center line grades. If the relation of the surface of the lot to the streets is such that visibility is already obscured, nothing shall be done to increase the impediment to visibility within the vertical and horizontal limits set forth above. Poles, tree trunks, and similar objects less than 12 inches in width may be allowed in the clear vision zone if they meet the vertical requirements noted above.

Response: As demonstrated by the Preliminary Landscape Plan in the Preliminary Plans (Exhibit A), clear vision areas are provided at the intersection of the planned driveways and adjacent public streets (W Baseline Street and S 1st Avenue, respectively). An existing clear vision area at the intersection of S 1st Avenue and W Baseline Street at the northwest corner of the site will be maintained as part of the planned improvements. Clear vision areas included with this application are planned to meet the standards of this section. This standard is met.

Chapter 18.155 Solar Access for New Development

18.155.040 Access to sunshine.

The elements of the development plan (e.g., buildings, circulation, open space and landscaping) shall be located and designed, to the maximum extent feasible, to protect access to sunshine for planned solar energy systems or for solar-oriented rooftop surfaces that can support a solar collector or collectors capable of providing for the anticipated hot water needs of the buildings in the project between the hours of 9:00 a.m. and 3:00 p.m. PST, on December 21st.

Response: The planned improvements will maximize the access to sunshine for future solar energy systems. This standard is met.

18.155.050 Shading.

- (A) The physical elements of the development plan shall be, to the maximum extent feasible, located and designed so as not to cast a shadow onto structures on adjacent property greater than the shadow which would be cast by a 25-foot hypothetical wall located along the property lines of the project between the hours of 9:00 a.m. and 3:00 p.m., PST, on December 21st. This

provision shall not apply to structures within the central mixed use (CMU) and corridor commercial (CC) zoning districts.

Response: The planned improvements include a new commercial building on Parcel 1 of the planned partition. The planned commercial building is located far enough from Parcel 2 to avoid shading impacts on any future buildings on that parcel. Parcel 1 and the planned commercial building are not adjacent to any other properties and therefore will not shade other nearby buildings. Parcel 2 is intended for future commercial improvements and the shading impacts of those improvements can be addressed by a future Site Design Review application. Therefore, this criterion is met.

(B) The impact of trees shall be evaluated on an individual basis considering the potential impacts of the shading and the potential adverse impacts that the shading could create for the adjacent properties in terms of blocking sunlight in indoor living areas, outdoor activity areas, gardens, and similar spaces benefiting from access to sunlight.

Response: This standard is understood and will be assessed upon installation of the planned trees and landscaping shown in the Preliminary Landscape Plan.

IV. Conclusion

The required findings have been made and this written narrative and accompanying documentation demonstrate that the application is consistent with the applicable provisions of the City of Cornelius Municipal Code. The evidence in the record is substantial and supports approval of the application.

Exhibit A: Preliminary Plans (Updated September 2023)

LEGEND

EXISTING	EXISTING
DECIDUOUS TREE	STORM DRAIN CLEAN OUT
CONIFEROUS TREE	STORM DRAIN CATCH BASIN
FIRE HYDRANT	STORM DRAIN AREA DRAIN
WATER BLOWOFF	STORM DRAIN MANHOLE
WATER METER	GAS METER
WATER VALVE	GAS VALVE
DOUBLE CHECK VALVE	GUY WIRE ANCHOR
AIR RELEASE VALVE	UTILITY POLE
SANITARY SEWER CLEAN OUT	POWER VAULT
SANITARY SEWER MANHOLE	POWER JUNCTION BOX
SIGN	POWER PEDESTAL
STREET LIGHT	COMMUNICATIONS VAULT
MAILBOX	COMMUNICATIONS JUNCTION BOX
	COMMUNICATIONS RISER

EXISTING

RIGHT-OF-WAY LINE	---
BOUNDARY LINE	---
PROPERTY LINE	---
CENTERLINE	---
DITCH	---
CURB	---
EDGE OF PAVEMENT	---
EASEMENT	---
FENCE LINE	---
GRAVEL EDGE	---
POWER LINE	---
OVERHEAD WIRE	---
COMMUNICATIONS LINE	---
FIBER OPTIC LINE	---
GAS LINE	---
STORM DRAIN LINE	---
SANITARY SEWER LINE	---
WATER LINE	---

NOTES:

- UTILITIES SHOWN ARE BASED ON UNDERGROUND UTILITY LOCATE MARKINGS AS PROVIDED BY OTHERS, PROVIDED PER UTILITY LOCATE TICKET NUMBERS 22253456 & 22253464. THE SURVEYOR MAKES NO GUARANTEE THAT THE UNDERGROUND LOCATES REPRESENT THE ONLY UTILITIES IN THE AREA. CONTRACTORS ARE RESPONSIBLE FOR VERIFYING ALL EXISTING CONDITIONS PRIOR TO BEGINNING CONSTRUCTION.
- VERTICAL DATUM: ELEVATIONS ARE BASED ON WASHINGTON COUNTY BENCHMARK NO. 470, LOCATED IN THE CONCRETE CURB AT THE SOUTHWEST CORNER OF STATE HIGHWAY 47 AND STATE HIGHWAY 8. ELEVATION = 174.994 FEET (NGVD 29).
- CONTOUR INTERVAL IS 1 FOOT.
- WETLAND BOUNDARY SHOWN WAS DELINEATED BY AKS ENGINEERING & FORESTRY, LLC ON AUGUST 24, 2022 AND WAS LOCATED USING A HANDHELD TRIMBLE GEO7X RECEIVER WITH SUBMETER ACCURACY.

TREE TABLE

TREE NUMBER	TYPE	DBH (IN.)
10382	DECIDUOUS	14,16
10391	DECIDUOUS	6,6,7,8,8
10392	DECIDUOUS	7
10393	DECIDUOUS	8
10474	DECIDUOUS	7
10477	DECIDUOUS	6
10504	DECIDUOUS	6
10609	CONIFEROUS	18

TREE TABLE

TREE NUMBER	TYPE	DBH (IN.)
10610	CONIFEROUS	12
10611	CONIFEROUS	8
11048	DECIDUOUS	7
11082	DECIDUOUS	9
11097	DECIDUOUS	15
11189	DECIDUOUS	12
15253	CONIFEROUS	30

CURVE TABLE

CURVE	RADIUS	DELTA	LENGTH	CHORD
C1	8624.37'	2'42"11"	406.89'	S81°15'14"W 406.85'
C2	8624.37'	0°03'57"	9.89'	S82°34'21"W 9.89'

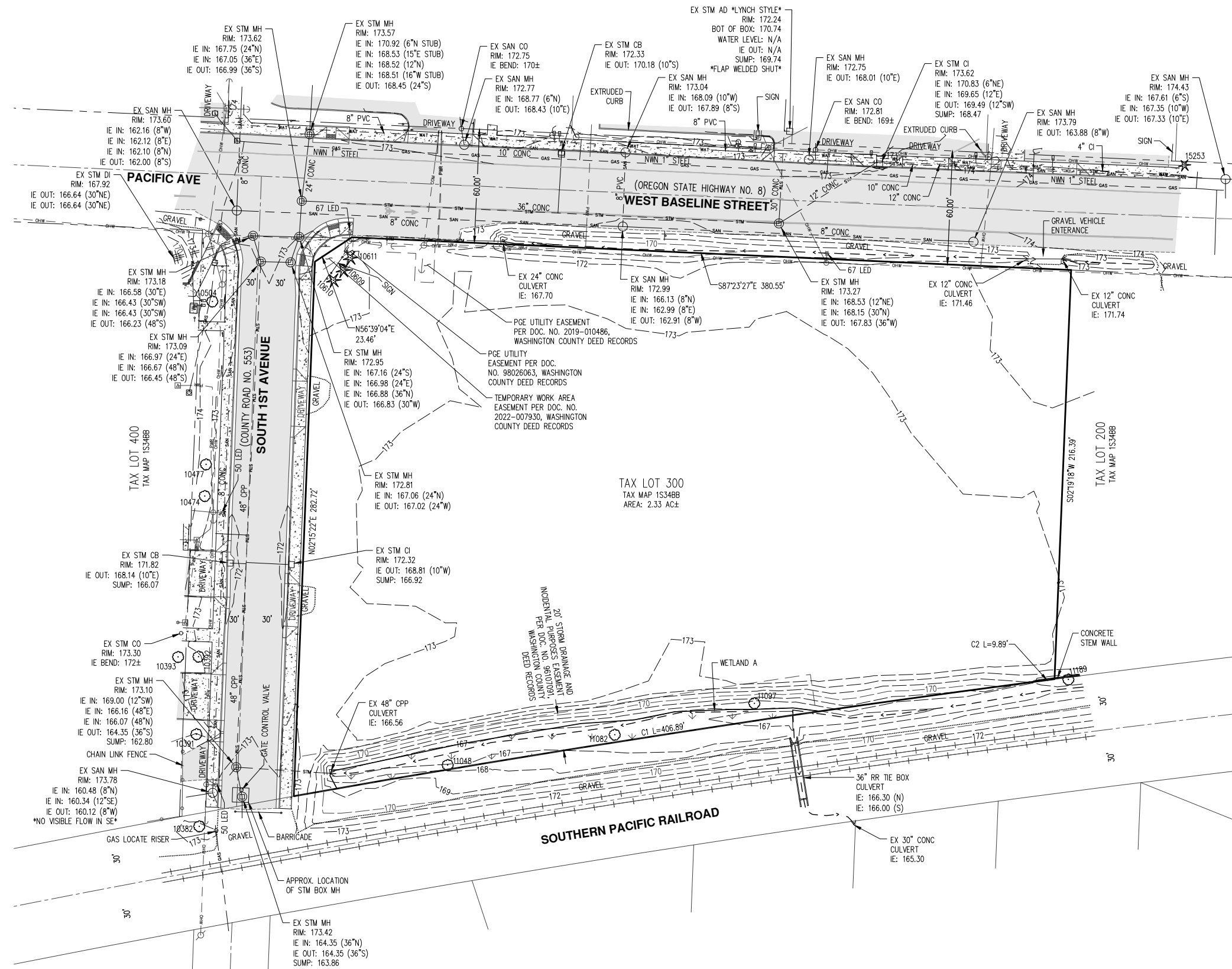
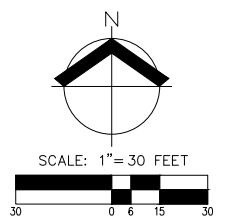

AKS DRAWING FILE: 9656_EXCOND.DWG | LAYOUT: LAYOUT1

PRELIMINARY PLAT
CORNELIUS SOUTH COMMERCIAL
 Cornelius, OR

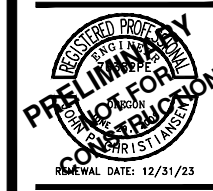

RENEWAL DATE: 12/31/23
 JOB NUMBER: 9656
 DATE: 9/18/2023
 DESIGNED BY: CMS
 DRAWN BY: JG
 CHECKED BY: CMS

C004

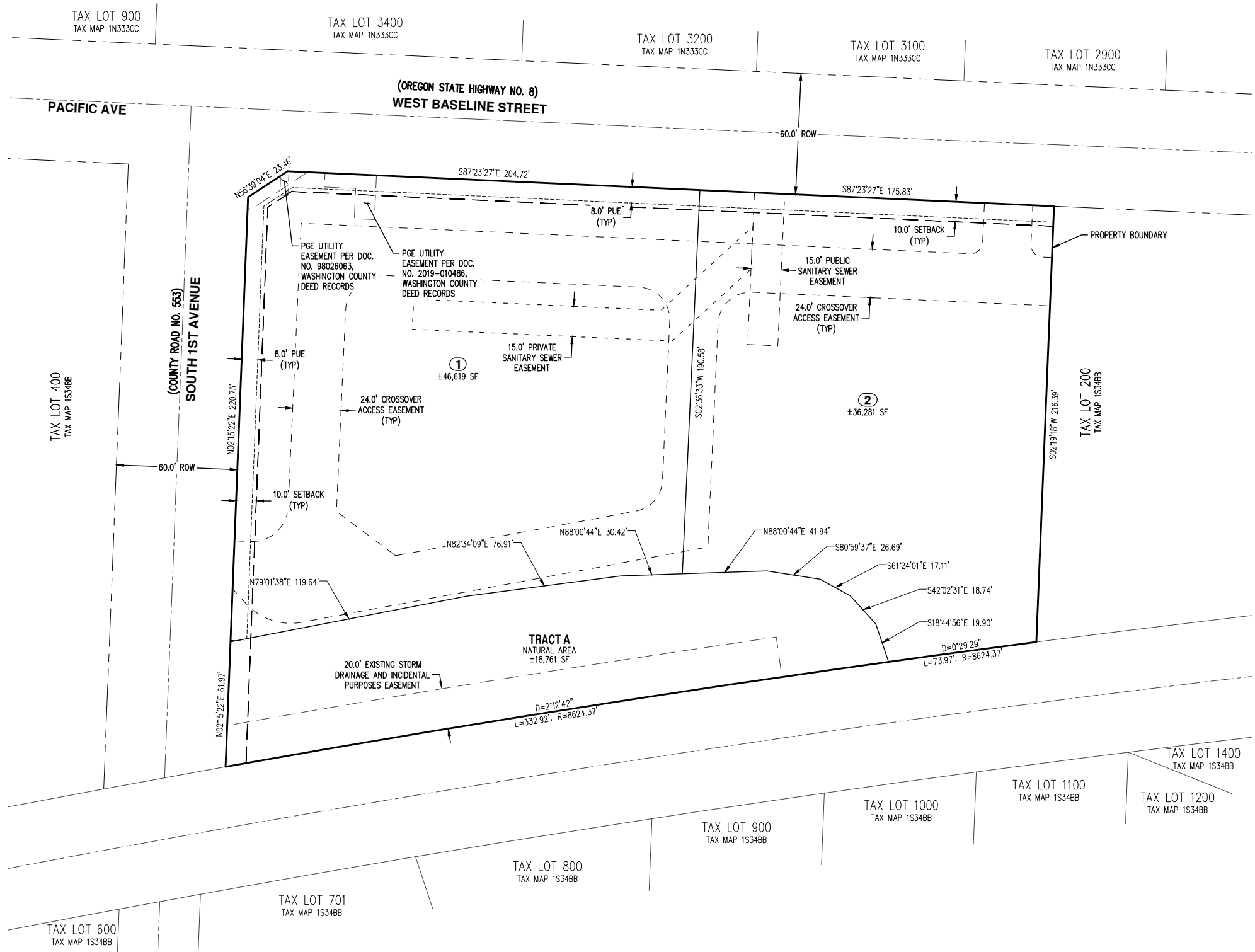

DISCLAIMER:

THE PURPOSE OF THIS PRELIMINARY PLAT IS TO SHOW THE PROPOSED PARTITION DIMENSIONS AND AREAS FOR PLANNING USE ONLY. THIS IS NOT AN OFFICIAL PLAT AND IS NOT TO BE USED FOR SURVEY PURPOSES.

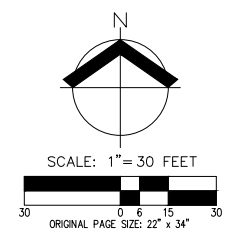

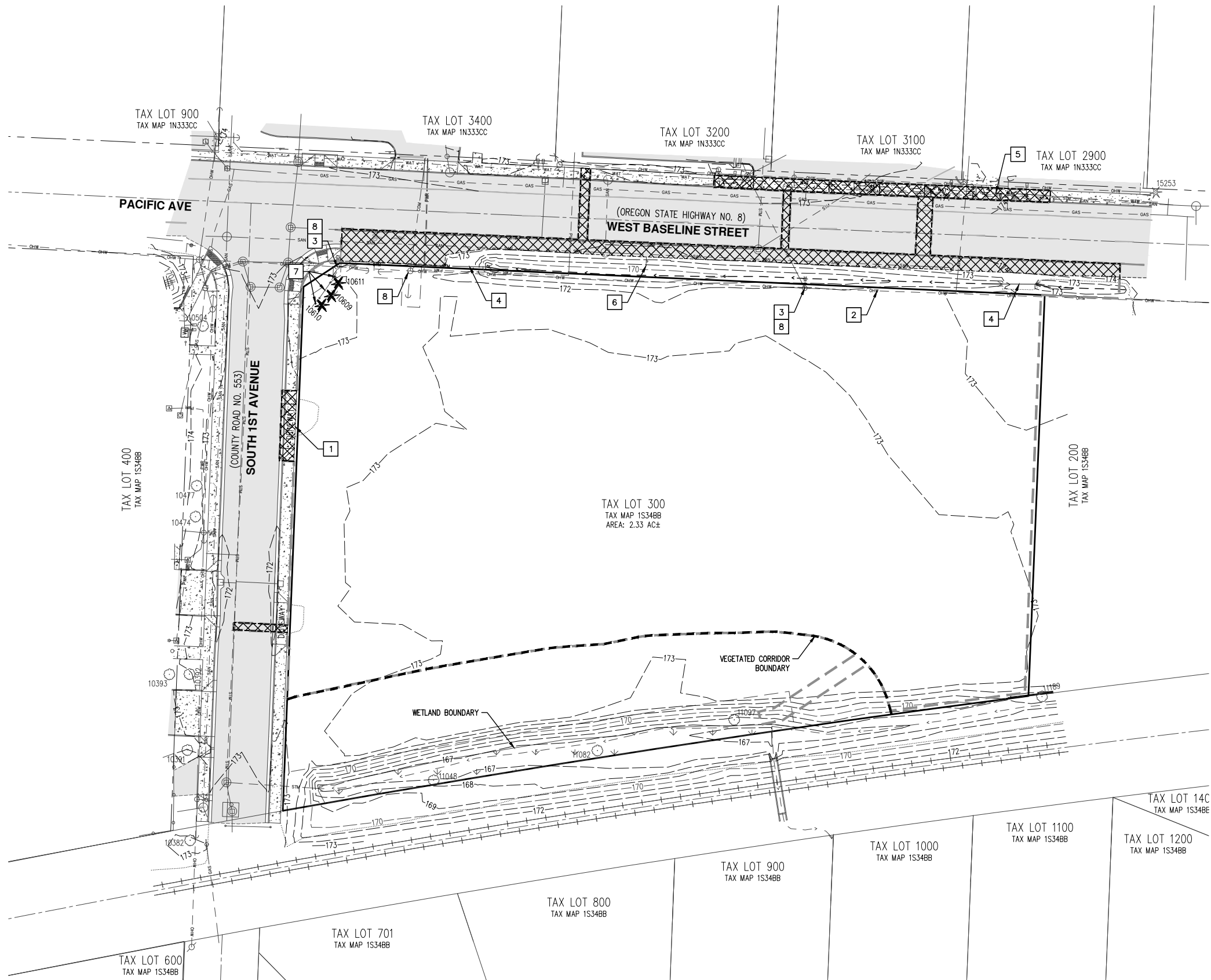

KEYED DEMOLITION NOTES: #

1. REMOVE EXISTING DRIVEWAY AND REPLACE WITH FULL HEIGHT SIDEWALK.
2. EXCLUDING HIGH TRANSMISSION POWER LINES, RELOCATE EXISTING OVERHEAD WIRES UNDERGROUND ALONG PROJECT FRONTAGE. CONTRACTOR TO COORDINATE WITH FRANCHISE UTILITY PROVIDERS.
3. REMOVE AND RELOCATE EXISTING STREET LIGHT ON POWER POLE TO SEPARATE POLE.
4. REMOVE/ABANDON/PLUG EXISTING STORMWATER CULVERT PER CITY AND ODOT STANDARDS.
5. REPLACE 4" CAST IRON WATER LINE WITH 8" C900.
6. COORDINATE WITH CITY FOR REMOVAL/RELOCATION OF EXISTING CITY LIMITS SIGNAGE.
7. PROTECT EXISTING SIGNAGE TO REMAIN.
8. EXISTING UTILITY POLES AND ASSOCIATED GUYS AND ANCHORS TO REMAIN.

TREE TABLE		
TREE NUMBER	TYPE	DBH (IN.)
10382	DECIDUOUS	14,16
10391	DECIDUOUS	6,6,7,8,8
10392	DECIDUOUS	7
10393	DECIDUOUS	8
10474	DECIDUOUS	7
10477	DECIDUOUS	6
10504	DECIDUOUS	6
10609	CONIFEROUS	18

TREE TABLE		
TREE NUMBER	TYPE	DBH (IN.)
10610	CONIFEROUS	12
10611	CONIFEROUS	8
11048	DECIDUOUS	7
11082	DECIDUOUS	9
11097	DECIDUOUS	15
11189	DECIDUOUS	12
15253	CONIFEROUS	30

LEGEND

EXISTING GROUND CONTOUR (1 FT) - - - - - 169 - - - - -

EXISTING GROUND CONTOUR (5 FT) - - - - - 170 - - - - -

LIMITS OF DISTURBANCE - - - - -

SAWCUT - - - - -

EXISTING TREE TO REMAIN ○ *

EXISTING TREE TO BE REMOVED ⊗ *

EXISTING PAVEMENT/CONCRETE TO BE REMOVED [X]

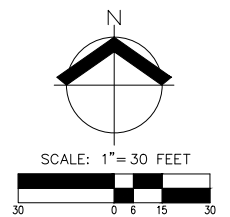

**PRELIMINARY DEMOLITION PLAN
 CORNELIUS SOUTH COMMERCIAL
 Cornelius, OR**



RENEWAL DATE: 12/31/23
 JOB NUMBER: 9656
 DATE: 9/18/2023
 DESIGNED BY: CMS
 DRAWN BY: JG
 CHECKED BY: CMS

**PRELIMINARY GRADING & EROSION & SEDIMENT CONTROL PLAN
 CORNELIUS SOUTH COMMERCIAL**

Cornelius, OR

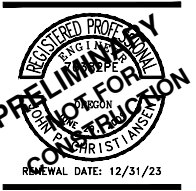

RENEWAL DATE: 12/31/23
 JOB NUMBER: 9656
 DATE: 9/18/2023
 DESIGNED BY: CMS
 DRAWN BY: JG
 CHECKED BY: CMS

C050

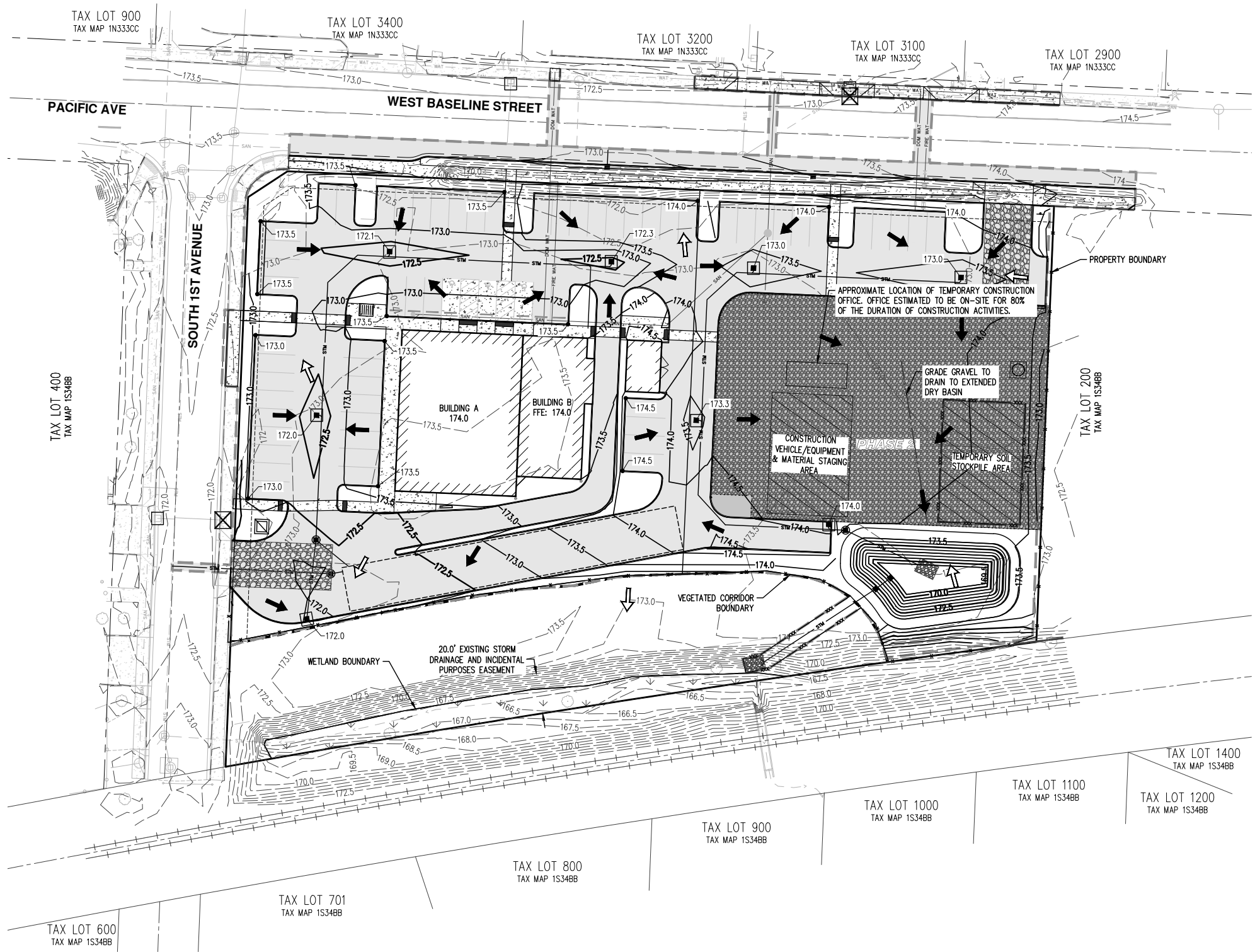

LEGEND

- EXISTING GROUND CONTOUR (0.5 FT)
- EXISTING GROUND CONTOUR (2.5 FT)
- FINISHED GRADE CONTOUR (0.5 FT)
- FINISHED GRADE CONTOUR (2.5 FT)
- SEDIMENT FENCE (TO BE INSTALLED PRIOR TO GRADING)
- STRAW WATTLES
- AREA DRAIN PROTECTION (TYP)
- CURB INLET PROTECTION (TYP)
- CONCRETE WASHOUT AREA
- SANITARY FACILITY (LOCATION APPROXIMATE)
- GRAVEL CONSTRUCTION ENTRANCE
- DISTURBED AREA BOUNDARY
- EXISTING GROUND DRAINAGE FLOW DIRECTION
- FINISHED GRADE DRAINAGE FLOW DIRECTION

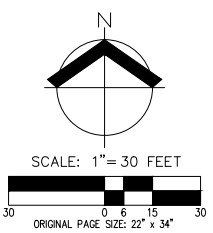

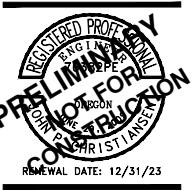

RENEWAL DATE: 12/31/23
 JOB NUMBER: 9656
 DATE: 9/18/2023
 DESIGNED BY: CMS
 DRAWN BY: JG
 CHECKED BY: CMS

SITE PLAN DATA:

ZONING = C-2 (HIGHWAY COMMERCIAL ZONE)
 TOTAL SITE AREA = ±101,661 SF (±2.33 ACRES)
 PROJECT AREA = ±102,802 SF (±2.36 ACRES)

PARKING SUMMARY:

PARCEL 1 PARKING = 52 SPACES
 PARCEL 2 PARKING = 11 SPACES

REQUIRED BICYCLE PARKING = 6 SPACES
 PROVIDED BICYCLE PARKING = 6 SPACES

SETBACKS:

FRONT YARD = 10 FT
 SIDE YARD = NONE
 REAR YARD = NONE

SITE KEYED NOTES:

1. NEW TYPE C CURB (TYP).
2. NEW BOLLARDS (TYP).
3. NEW EXTENDED DRY BASIN.
4. NEW ADA ACCESSIBLE CURB RAMP WITH DETECTABLE WARNING SURFACE (TYP).
5. NEW ADA ACCESSIBLE PARKING SIGN (TYP).
6. NEW ADA ACCESSIBLE PARKING STALLS AND AISLE STRIPING (TYP).
7. NEW SIDEWALK WITH CURB AND GUTTER (TYP).
8. NEW BIKE RACK (TYP). SEE DETAIL 2 ON SHEET A1.02 FOR ADDITIONAL INFORMATION.
9. NEW PARKING STRIPING (TYP).
10. NEW COVERED TRASH ENCLOSURE MEETING THE APPLICABLE SCREENING REQUIREMENTS PER CITY OF CORNELIUS MUNICIPAL CODE SECTION 18.45.060(F). SEE DETAILS ON SHEET A1.03 FOR ADDITIONAL INFORMATION.
11. NEW ADA ACCESSIBLE CONCRETE PEDESTRIAN CROSSING (TYP).
12. NEW LIGHTING SHOWN FOR REFERENCE ONLY, SEE PHOTOMETRIC PLAN FOR ADDITIONAL INFORMATION.
13. NEW DIRECTIONAL ARROW STRIPE (TYP).
14. NEW COMMERCIAL DRIVEWAY APPROACH PER ODOT.
15. NEW BIKE LANE STRIPING PER ODOT STANDARDS.
16. NEW SIDEWALK PER ODOT STANDARDS.
17. NEW UNDERGROUND STORMWATER DETENTION FACILITY.
18. NEW STOP SIGN AND STOP BAR.
19. NEW LOADING BERTH.
20. NEW FENCE FOR ANTICIPATED RECREATIONAL SPACE FOR CHILDREN'S AREA. SEE DETAIL 1 ON SHEET A1.02 FOR ADDITIONAL INFORMATION.
21. NEW WHEEL STOP (TYP).
22. APPROXIMATE LOCATION OF ANTICIPATED MENU BOARD. FINAL LOCATION AND DETAILED INFORMATION WILL BE INCLUDED WITH BUILDING PERMIT APPLICATION.
23. APPROXIMATE LOCATION OF ANTICIPATED HEIGHT BAR. FINAL LOCATION AND DETAILED INFORMATION WILL BE INCLUDED WITH BUILDING PERMIT APPLICATION.

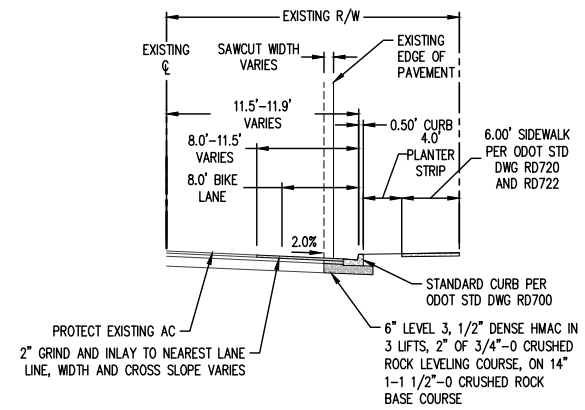

1 West Baseline Street Typical Section
 NOT TO SCALE

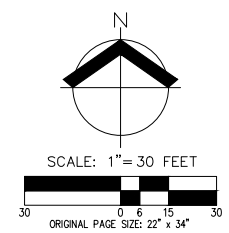
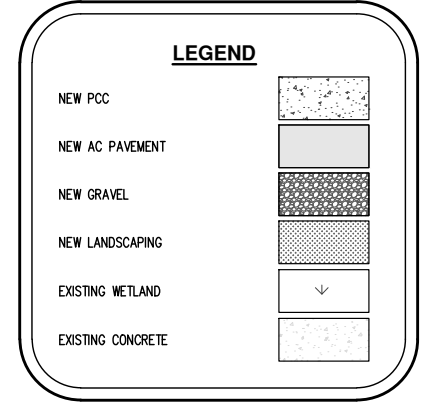
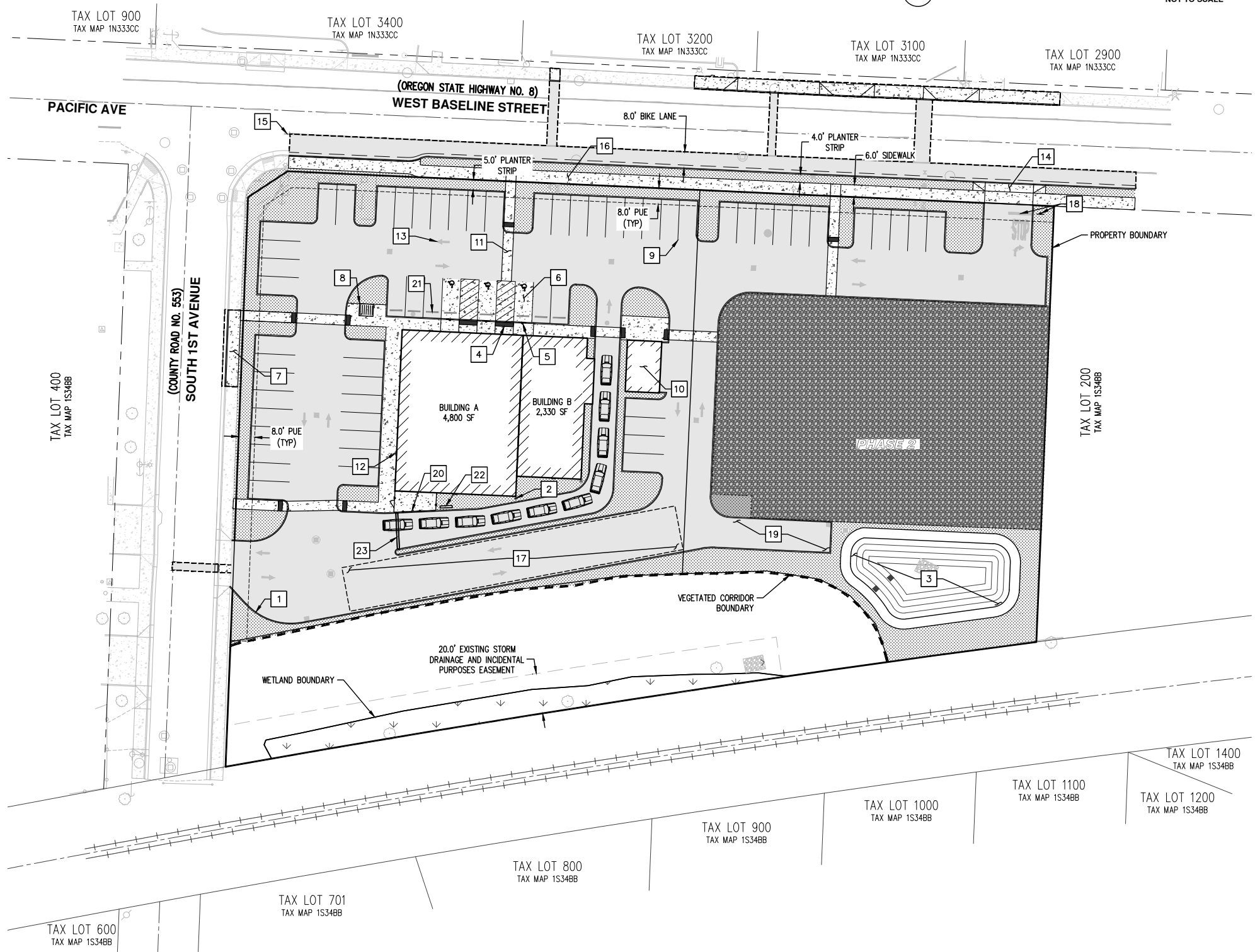

**PRELIMINARY DIMENSIONED SITE PLAN
 CORNELIUS SOUTH COMMERCIAL**

Cornelius, OR



RENEWAL DATE: 12/31/23
 JOB NUMBER: 9656
 DATE: 9/18/2023
 DESIGNED BY: CMS
 DRAWN BY: JG
 CHECKED BY: CMS

C101

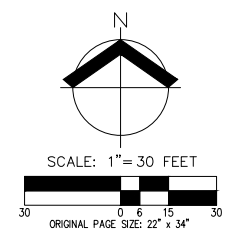
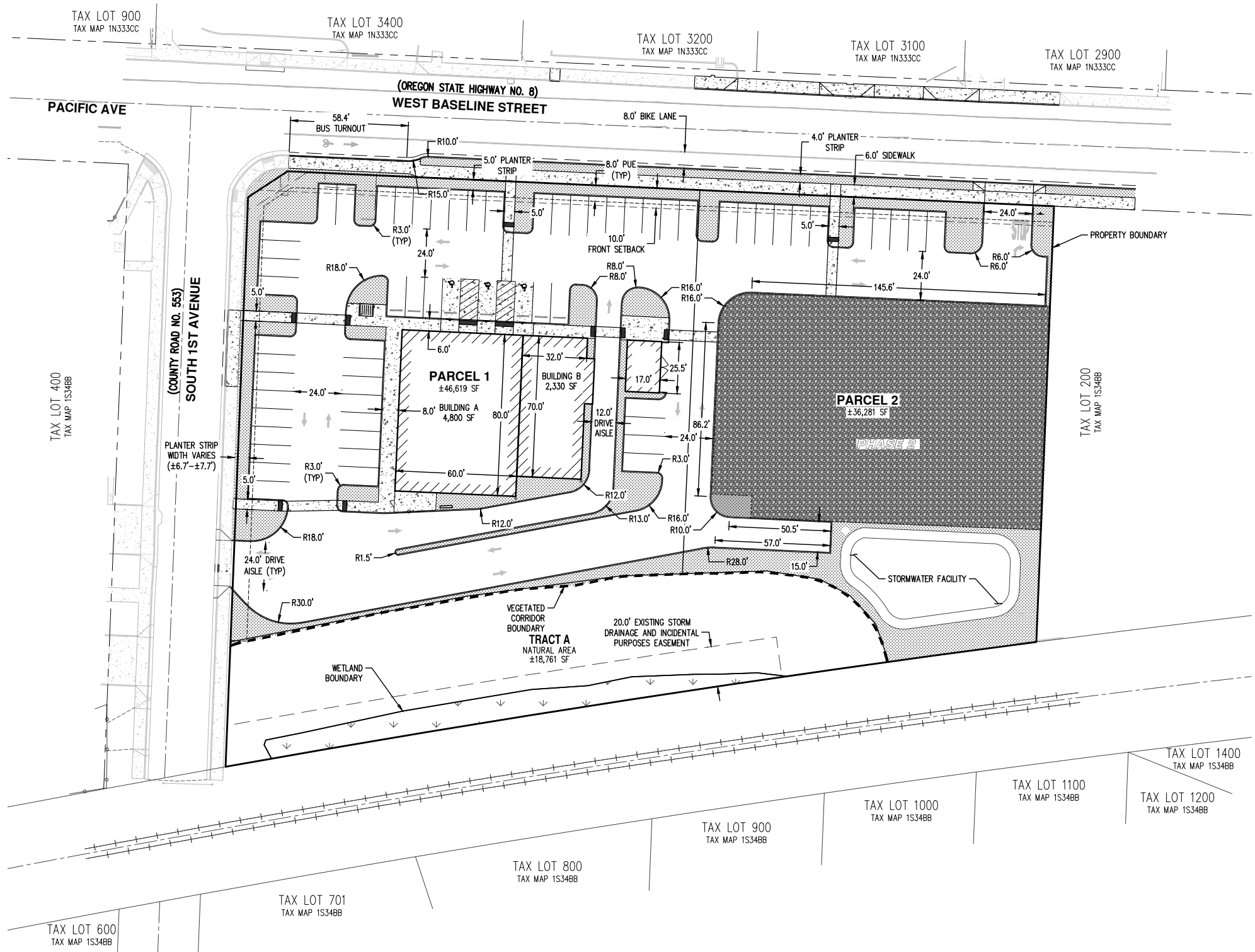

AKS DRAWING FILE: 9656 PRELIM DIMENSIONED SITE PLANS.DWG | LAYOUT: C101

Dot Outdoor Wall / Ceiling Light

Type D

Lightology



Description:
The Dot Flush Mount features a finely crafted diffuser which amplifies the brightness on this durable waterproof outdoor flush mount while also showing off its impressive height and depth. Rerendered in highly durable marine-grade stainless steel, Dot withstands the toughest conditions but can complement interior finishes just as well. Available in three sizes with choice of 3000K or 3500K color temperature.

Shown in: Stainless Steel / Clear

Shade Color: Clear
Body Finish: Stainless Steel
Lamp: 1 x LED/18.5W/120V LED
Wattage: 18.5W
Dimmer: Low Voltage Electronic
Dimensions: 9"W x 2.5"H

Technical Information
Luminous Flux: 1150 lumens
Lumens/Watt: 62.16
Lamp Color: 3000 K
Color Rendering: 90 CRI
Lamp Life: 54000 hours

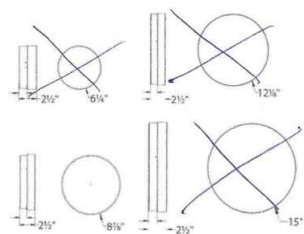

Product Number: DWE615574

Company:	Fixture Type:	Date:
Project:	Approved By:	Jan 02, 2019



RGM Series
Medium Glass Refractor LED Wallpack

DESCRIPTION
Trace-Lite's latest generation - medium glass refractor LED wallpack features an updated LED light engine with greater efficacy, lumen output and thermal management while still maintaining the consistency of our proven traditional housing. The RGM housing is constructed of die-cast aluminum in a dark bronze finish that provides durable protection against environmental conditions, corrosion and the elements. It is UL Listed for Wet Locations. RGM's light engine is protected by a high-impact, prismatic, borosilicate glass lens and offers maximum light output for general purpose area and security lighting. Optional battery backup option available. This versatile luminaire is ideal to match existing or retrofit HID legacy designs.

SPECIFICATIONS
Construction:
• Precision die-cast aluminum housing with UV resistant, thermoset polyester powder coat with a dark bronze finish
• Stainless steel hardware
• Prismatic borosilicate glass refractor
• Hinged housing design for ease of installation and maintenance
• 1/2" knockout on both sides and top of unit

Optics/LEDs:
• 30w COB LED light engine providing up to 3468 lumens
• 40w COB LED light engine providing up to 4780 lumens
• 4000K or 5000K CCT
• CRI ≥ 71

Electrical:
• Class 2 power supply, voltage sensing 120-277VAC, 50/60Hz
• Standard 0-10VDC dimming driver
• 10kVA surge protection
• L70 rated for 60,000 hours at 40°C

Testing & Compliance:
• cULus Listed for Wet Locations
• Operating temperatures: -20°C to 40°C (-4°F to 104°F)

Installation:
• Ideal for mounting to any vertical surface and attaches to a 3" or 4" j-box
• Can be surface mounted using the 1/2" conduit entry point on both sides of the housing

Options:
• Battery backup offers 90 minutes of runtime for path of egress. Rated for ambient temperatures between 0°C to 40°C (32°F to 104°F)

Accessories:
• Field installed button type photocontrol, 120VAC or 277VAC (PC1/PC2)
• Dimming occupancy sensor programmable, Wattstopper FSP221 available in white and bronze finish (TL-SCES-L2)

Warranty:
• Five Year Warranty (Terms and Conditions Apply)

Model: _____ Date: _____
Accessories: _____
Job Name: _____ Type: _____

AVAILABLE WHILE SUPPLIES LAST



Specs at a Glance

Wattage (W)*	30W	40W
Lumens (lm)	3468	4780
Efficacy (LPW)	123	120
Equivalency (HID)	150W	250W
CCT (K)	4000K, 5000K	
CRI	≥71	
Input Voltage	120-277VAC, 50/60Hz	
Operating Temp	-20°C to 40°C (-4°F to 104°F)	
Certifications	UL/cUL Listed for Wet Locations	
Weight	12.8 lbs.	
Warranty	5 Years	

*Nominal Wattage. Tested at 5000K CCT.
Note: Environment and application will affect actual performance. Typical values and 25°C used for testing.

WP-1

Address: 1718 W. Fullerton Ave, Chicago, IL 60614
Phone: 866-954-4489
Fax: (773) 883-6131
www.lightology.com

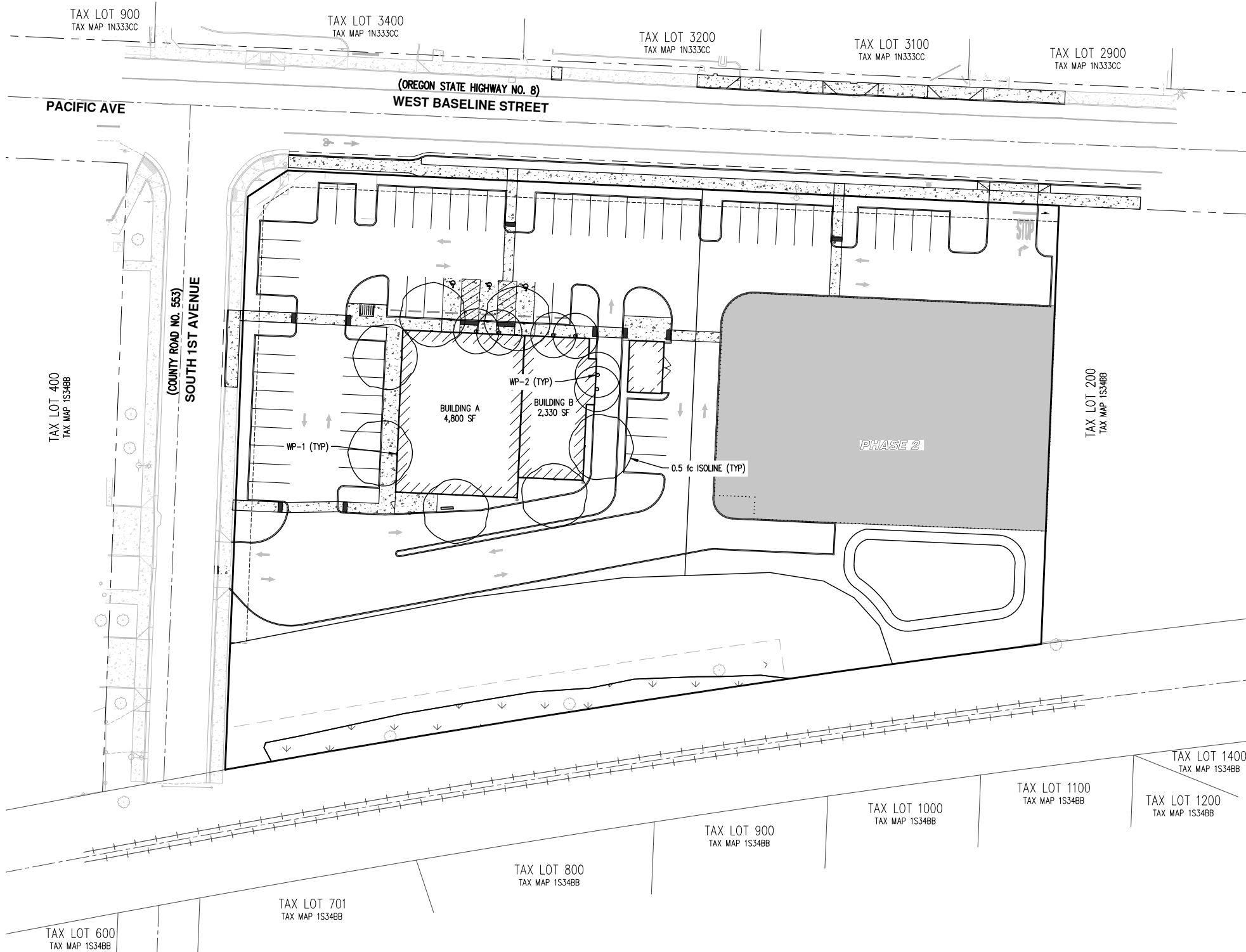

LUMINAIRE AND POLE SCHEDULE

LABEL	TAG	DESCRIPTION	MOUNTING HEIGHT (FT)	QTY	TOTAL LUMENS	LUM. WATTS	LLF
WP-1	NEW	TRACE LITE RGM SERIES LED WALLPACK (RGM-30-VS)	9	7	3,468	30	0.9
WP-2	NEW	WAC LIGHTING DOT OUTDOOR WALL/CEILING (DWE615574)	9	6	1,150	18.5	0.9

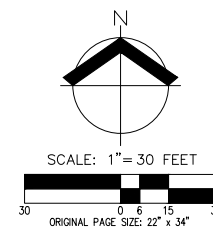

AKS
AKS ENGINEERING & FORESTRY, LLC
12965 SW HERMAN RD, STE 100
TUALATIN, OR 97062
503.563.6151
WWW.AKS-ENG.COM
ENGINEERING • SURVEYING • NATURAL RESOURCES
FORESTRY • PLANNING • LANDSCAPE ARCHITECTURE

PRELIMINARY SITE LIGHTING PLAN
CORNELIUS SOUTH COMMERCIAL
Cornelius, OR

REGISTERED PROFESSIONAL ENGINEER
PRELIMINARY
NOT FOR CONSTRUCTION
RENEWAL DATE: 12/31/23
JOB NUMBER: 9656
DATE: 9/18/2023
DESIGNED BY: CMS
DRAWN BY: JG
CHECKED BY: CMS

C102

AKS DRAWING FILE: 9656 PRELIM LIGHTING.DWG | LAYOUT: C102

Specifications are subject to change without notice. Installation must be performed in accordance with Barron Lighting Group installation instructions.

BARRON Lighting Group
800.533.3948 • barronllg.com

**PRELIMINARY COMPOSITE UTILITY PLAN
 CORNELIUS SOUTH COMMERCIAL**

Cornelius, OR

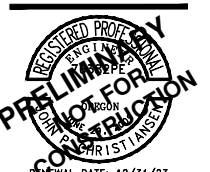

RENEWAL DATE: 12/31/23
 JOB NUMBER: 9656
 DATE: 9/18/2023
 DESIGNED BY: CMS
 DRAWN BY: JG
 CHECKED BY: CMS

C300

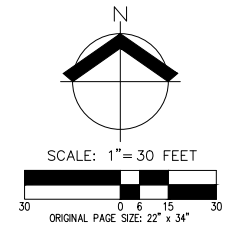
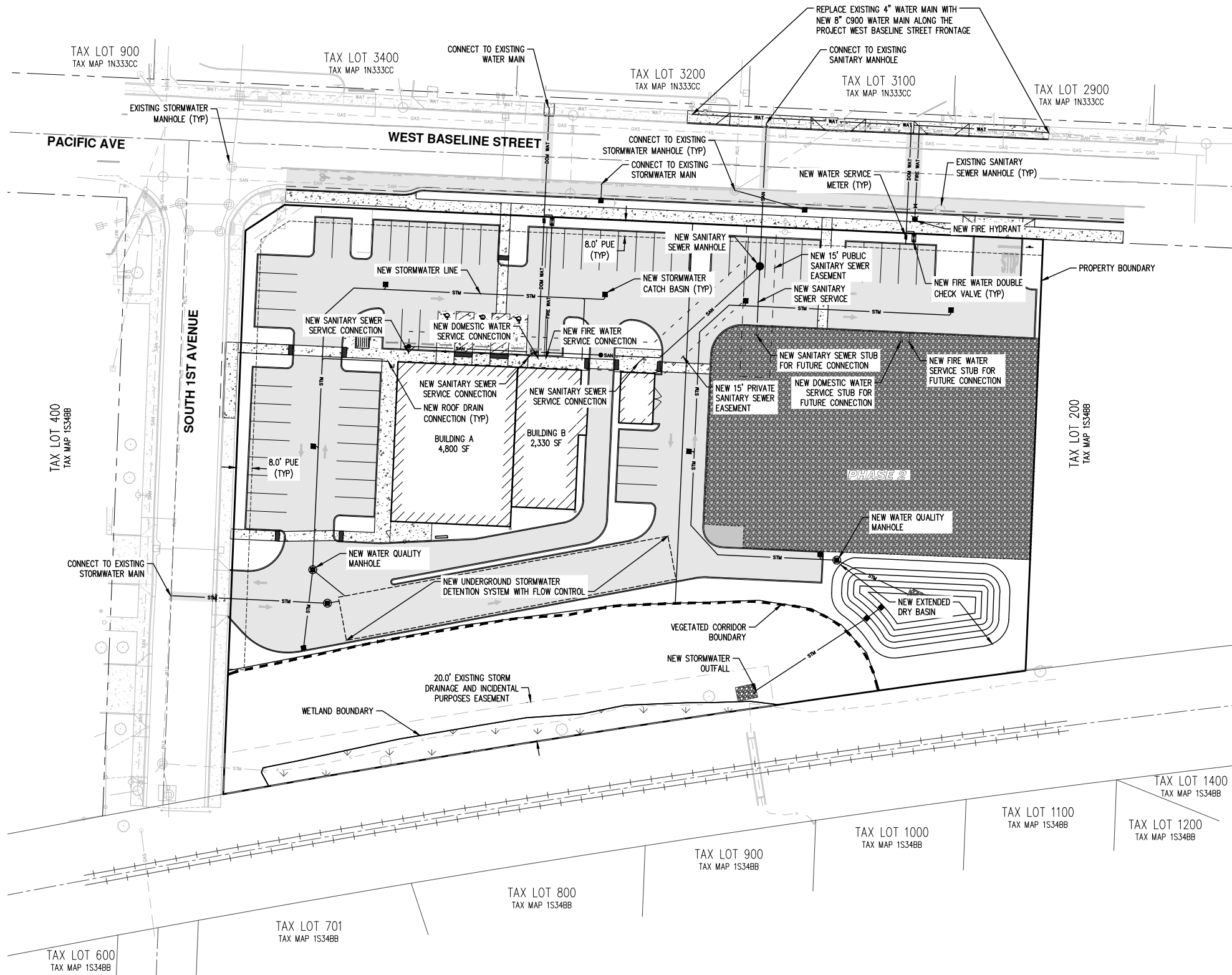

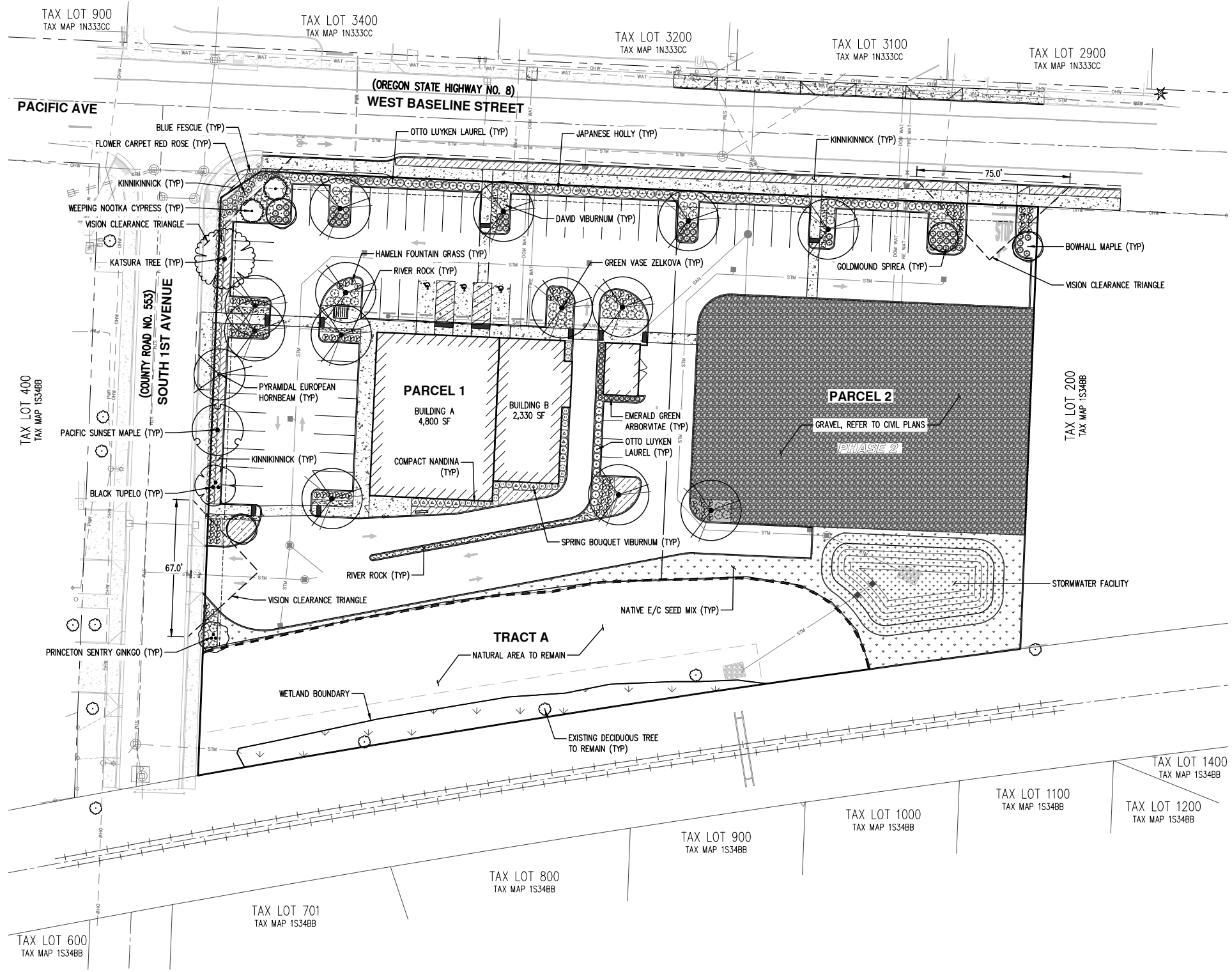

PRELIMINARY PLANT SCHEDULE

TREES	QTY	BOTANICAL NAME	COMMON NAME	SIZE/CONTAINER	SPACING
	4	ACER RUBRUM 'BOWHALL'	BOWHALL RED MAPLE	2" CAL. B&B	AS SHOWN
	2	CHAMAECYPARIS NOOTKATENSIS 'PENDULA'	WEeping NOOTKA CYPRESS	6" HT. B&B	AS SHOWN
	13	ZELKOVA SERRATA 'GREEN VASE'	GREEN VASE ZELKOVA	2" CAL. B&B	AS SHOWN
STREET TREES					
TREES	QTY	BOTANICAL NAME	COMMON NAME	SIZE/CONTAINER	SPACING
	1	ACER TRUNCATUM 'WARREN RED'	PACIFIC SUNSET MAPLE	2" CAL. B&B	AS SHOWN
	1	CARPINUS BETULUS 'FASTIGIATA'	PYRAMIDAL EUROPEAN HORNBEAN	2" CAL. B&B	AS SHOWN
	1	CERCIDIPHYLLUM JAPONICUM	KATSURA TREE	2" CAL. B&B	AS SHOWN
	1	GINKGO BILOBA 'PRINCETON SENTRY'	PRINCETON SENTRY GINKGO	2" CAL. B&B	AS SHOWN
	1	NYSSA SYLVATICA	BLACK TUPELO	2" CAL. B&B	AS SHOWN
SHRUBS					
TREES	QTY	BOTANICAL NAME	COMMON NAME	SIZE/CONTAINER	SPACING
	61	ILEX CRENATA	JAPANESE HOLLY	2 GAL. CONT.	48" o.c.
	22	NANDINA DOMESTICA 'COMPACTA'	COMPACT NANDINA	1 GAL. CONT.	36" o.c.
	63	PRUNUS LAUROCERASUS 'OTTO LUYKEN'	OTTO LUYKEN LAUREL	2 GAL. CONT.	48" o.c.
	18	ROSA X 'NOARE'	FLOWER CARPET RED ROSE	1 GAL. CONT.	36" o.c.
	52	SPIRAEA JAPONICA 'GOLDMOUND'	GOLDMOUND JAPANESE SPIREA	1 GAL. CONT.	36" o.c.
	18	THUJA OCCIDENTALIS 'SMARAGD'	EMERALD GREEN ARBORVITAE	4-5" HT. CONT.	30" o.c.
	57	VIBURNUM DAVIDII	DAVID VIBURNUM	1 GAL. CONT.	48" o.c.
	13	VIBURNUM TINUS 'SPRING BOUQUET'	SPRING BOUQUET LAURUSTINUS	1 GAL. CONT.	48" o.c.
ORNAMENTAL GRASSES					
TREES	QTY	BOTANICAL NAME	COMMON NAME	SIZE/CONTAINER	SPACING
	16	FESTUCA GLAUCA	BLUE FESCUE	1 GAL. CONT.	30" o.c.
	91	PENNISETUM ALOPECUROIDES 'HAMELN'	HAMELN FOUNTAIN GRASS	1 GAL. CONT.	36" o.c.
GROUND COVERS					
TREES	QTY	BOTANICAL NAME	COMMON NAME	SIZE/CONTAINER	SPACING
	281	ARCTOSTAPHYLOS UVA-URSI	KINNIKINICK	1 GAL. CONT.	36" o.c.
	±4,150 SF	NATIVE E/C SEED MIX - SUNMARK SEEDS (OR APPROVED EQUAL)			
	±3,652 SF	STORMWATER FACILITY - TO BE PLANTED PER CITY OF CORNELIUS STANDARDS			
		RIVER ROCK			

SITE DATA

ZONING =	C-2 (HIGHWAY COMMERCIAL ZONE)
TOTAL SITE AREA =	±101,661 SF (±2.33 ACRES)
PROJECT AREA =	±102,802 SF (±2.36 ACRES)
LANDSCAPE AREA =	±15,492 SF (15.2% OF SITE)

PRELIMINARY LANDSCAPE NOTES

- LANDSCAPE PLANTING SHALL CONFORM TO THE STANDARDS ESTABLISHED UNDER THE CITY OF CORNELIUS, INCLUDING ALL CURRENT AND APPLICABLE MUNICIPAL CODE SECTIONS.
- ALL PLANT BEDS SHALL HAVE 3" DEPTH OF BARK MULCH.
- LANDSCAPE AREAS SHALL HAVE A COMPLETE UNDERGROUND AUTOMATIC IRRIGATION SYSTEM WITH FULL LANDSCAPE COVERAGE, OPERATIONAL AT TIME OF PLANTING. IRRIGATION IS TO BE DESIGN-BUILD BY LANDSCAPE CONTRACTOR.
- ALL PLANT MATERIAL DELIVERED TO THIS SITE SHALL MEET THE AMERICAN STANDARDS FOR NURSERY STOCK.

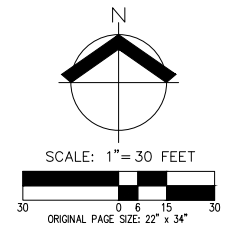

STREET TREE DIVERSITY

FAMILY	GENUS	SPECIES
SAPINDACEAE	ACER	TRUNCATUM
BETULACEAE	CARPINUS	BETULUS
CERCIDIPHYLLACEAE	CERCIDIPHYLLUM	JAPONICUM
GINKGOACEAE	GINKGO	BILOBA
CORNALES	NYSSA	SYLVATICA

PRELIMINARY LANDSCAPE PLAN
CORNELIUS SOUTH COMMERCIAL
 Cornelius, OR



JOB NUMBER:	9656
DATE:	9/18/2023
DESIGNED BY:	TEB
DRAWN BY:	TEB
CHECKED BY:	CMS

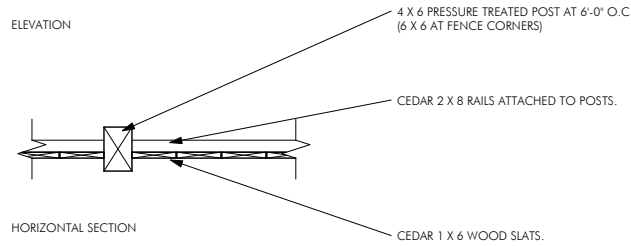
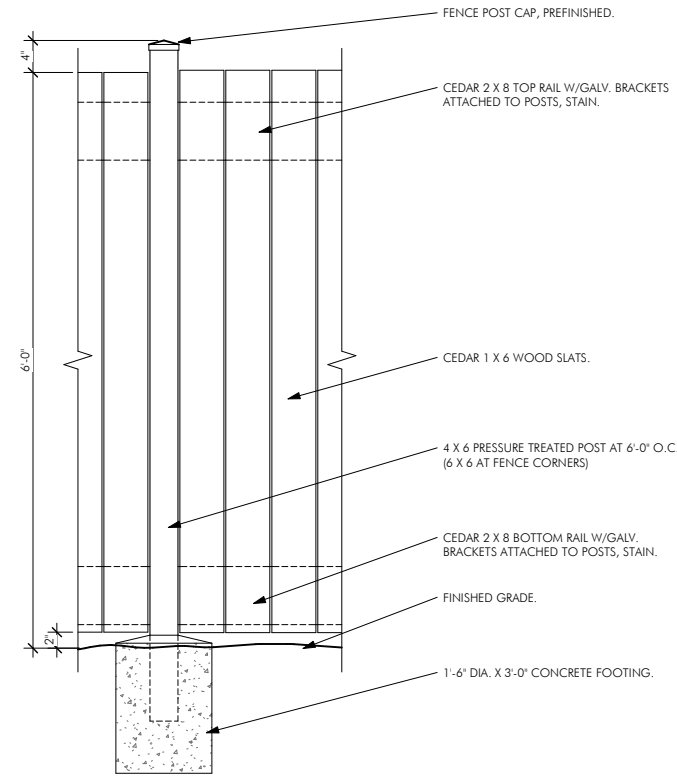

1 FENCE DETAIL
0" 1/4" 1/2" 1" 2" 3" 1" = 1'-0"

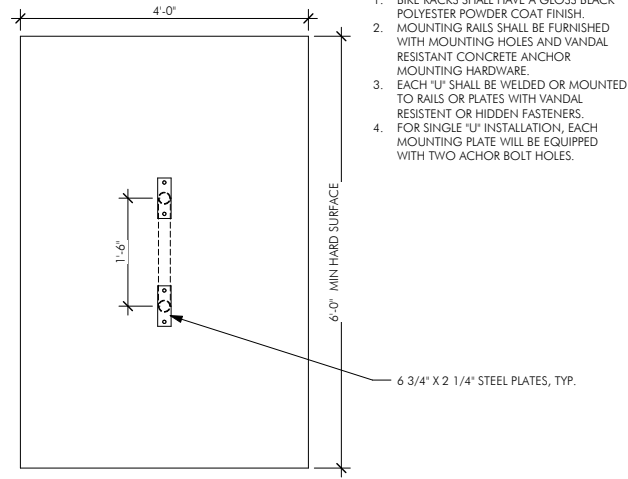

2 INVERTED U BIKE RACK DETAIL
0" 6" 1" 2" 3/4" = 1'-0"

- NOTES:
- BIKE RACKS SHALL HAVE A GLOSS BLACK POLYESTER POWDER COAT FINISH.
 - MOUNTING RAILS SHALL BE FURNISHED WITH MOUNTING HOLES AND VANDAL RESISTANT CONCRETE ANCHOR MOUNTING HARDWARE.
 - EACH "U" SHALL BE WELDED OR MOUNTED TO RAILS OR PLATES WITH VANDAL RESISTANT OR HIDDEN FASTENERS.
 - FOR SINGLE "U" INSTALLATION, EACH MOUNTING PLATE WILL BE EQUIPPED WITH TWO ANCHOR BOLT HOLES.

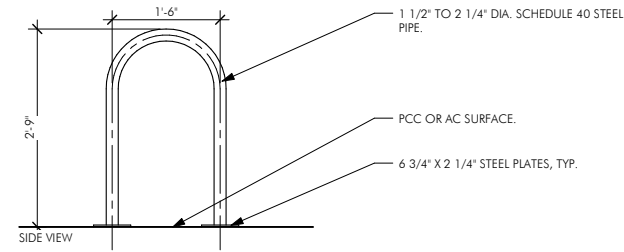

SIDE VIEW

KEYNOTES:

- 1 SPLIT FACE CMU BLOCK ENCLOSURE
- 2 GALVANIZED STEEL LOCKABLE CANE BOLTS FOR GATE
- 3 OIL SEPARATOR
- 4 14x3" WIDE GATE WITH HEAVY DUTY GALVANIZED STRAP HINGES AND CANE BOLT WITH SLEEVE IN CONCRETE PAD
- 5 90 GALLON RECYCLING BIN
- 6 6 CUBIC YARD TRASH BIN
- 7 CONCRETE FOOTING, SEE STRUCTURAL
- 8 CAP STONE TO MATCH CMU BLOCK, 1" OVERHANG TYP. AT ALL EDGES
- 9 CONCRETE SLAB, SEE STRUCTURAL. SLOPE FLOOR OF TRASH ENCLOSURE TO INTERIOR DRAIN
- 10 PROVIDE GATE STOP AND HOOK TO RESTRAIN GATE IN OPEN POSITION WHEN IN USE
- 11 GALVANIZED STEEL SLEEVE SET IN CONCRETE, (OPEN TO DRAIN BELOW CONCRETE SLAB), TO RECEIVE GATE CANE BOLT.
- 12 H.D. WELDABLE HINGES
- 13 4x4" TUBE STEEL POST FILLED W/CONCRETE. PAINT TO MATCH ADJ. SURFACE.
- 14 TUBE STEEL, SEE STRUCTURAL
- 15 GALVANIZED METAL DECKING, SEE STRUCTURAL
- 16 ROOF LINE FROM ABOVE

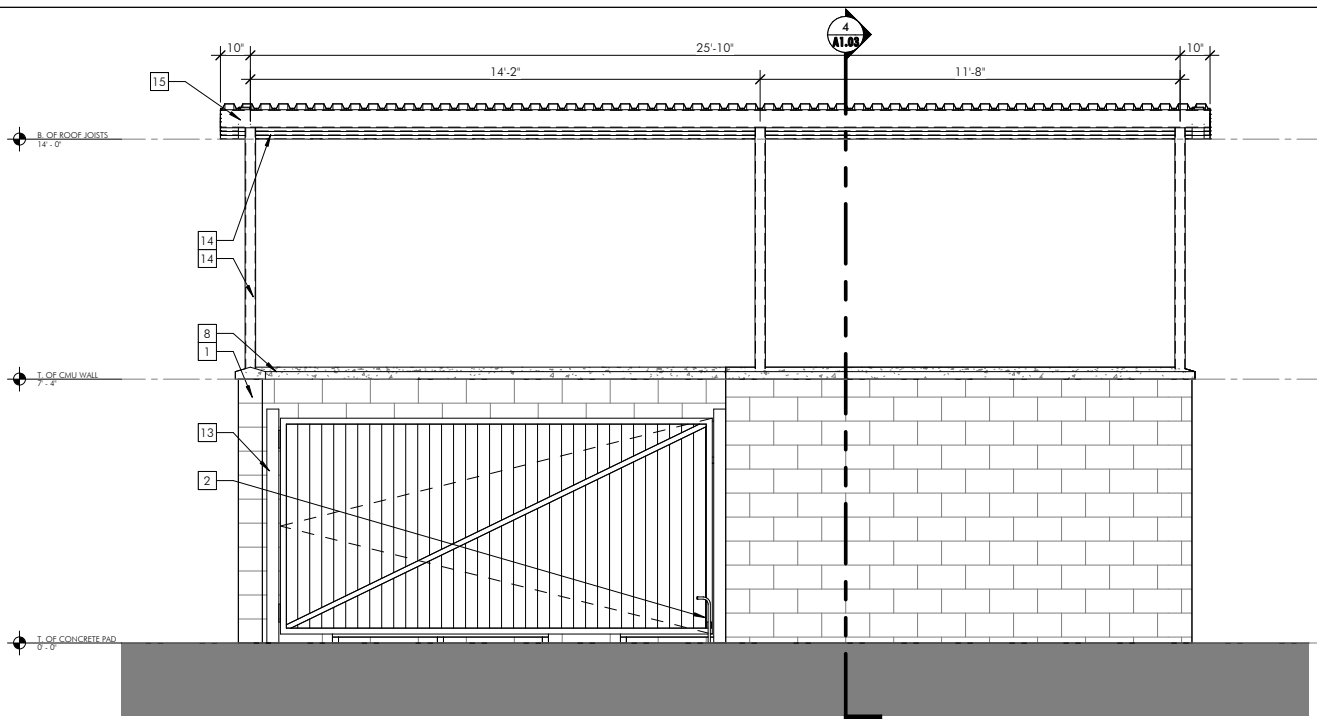

1 TRASH ENCLOSURE - FRONT ELEVATION

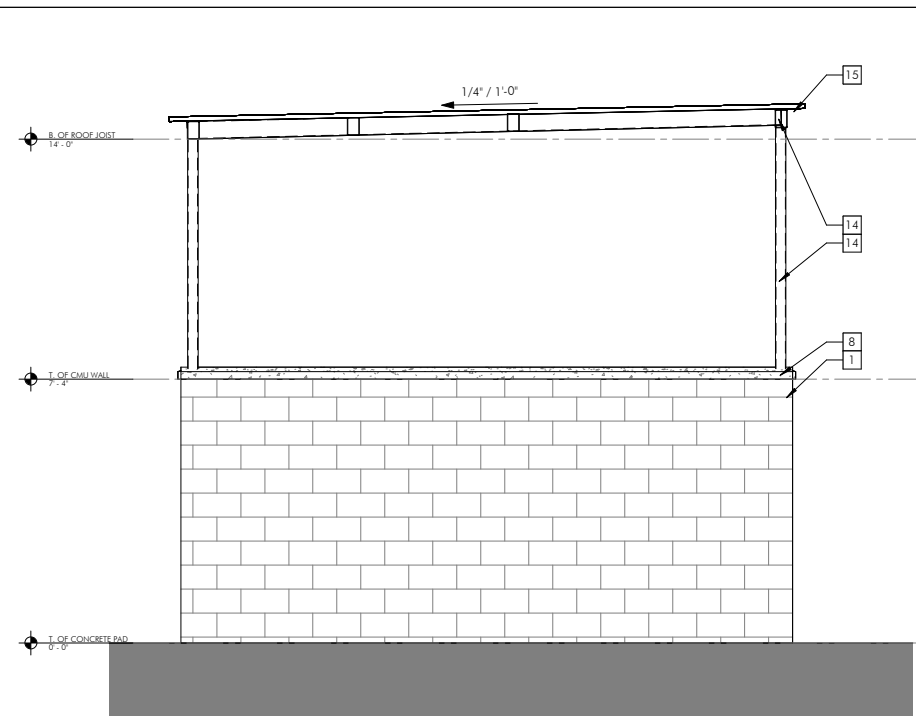

3 TRASH ENCLOSURE - SIDE ELEVATION

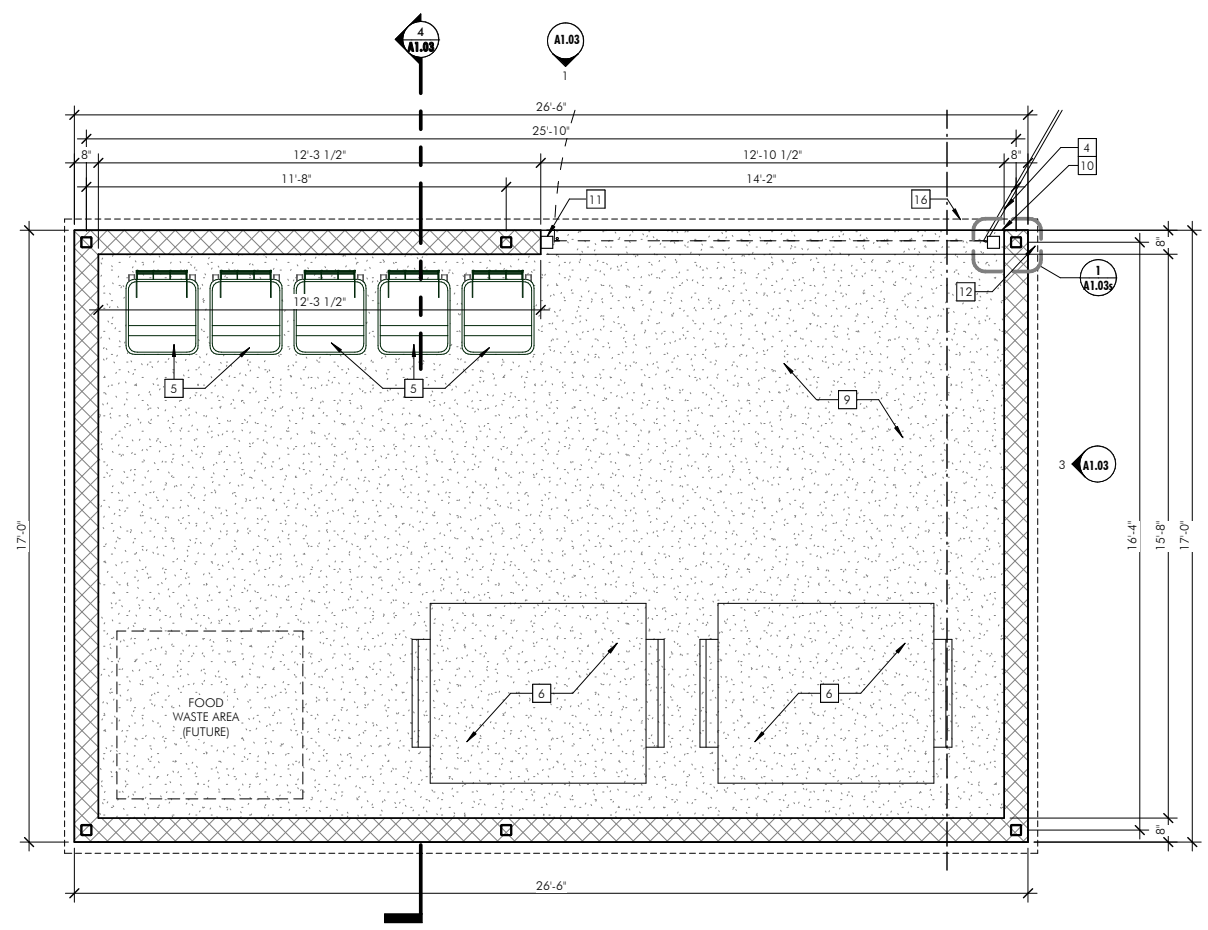

2 TRASH ENCLOSURE PLAN

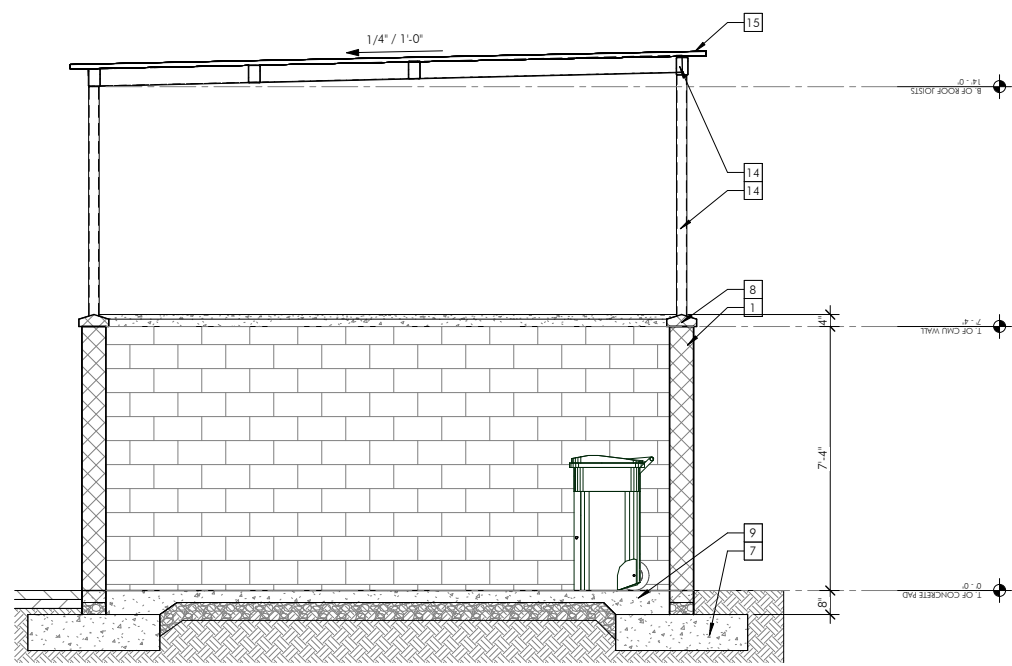

4 TRASH ENCLOSURE SECTION

GENERAL PLAN NOTES:

1. GENERAL NOTES APPLY TO ALL DRAWINGS.
2. DRAWINGS ARE DIAGRAMMATIC ONLY AND SHOULD NOT BE SCALED. NOTIFY ARCHITECT OF ANY DISCREPANCIES IMMEDIATELY UPON DISCOVERY. OBTAIN CLARIFICATION OF DIMENSIONS OR DISCREPANCIES PRIOR TO PROCEEDING WITH AREA OF REQUIRED WORK.
3. DIMENSIONS ARE TO FACE OF FRAMING. DIMENSIONS STATED AS CLEAR ARE TO FACE OF FINISH.
4. SEE WALL SECTIONS AND BUILDING ELEVATIONS FOR DESCRIPTION OF EXTERIOR WALL MATERIALS.
5. COORDINATE LOCATION OF RECESSED OR SEMI-RECESSED ITEMS TO AVOID BACK TO BACK INSTALLATION AND TO REDUCE NOISE TRANSFER THROUGH PARTITIONS.
6. INSTALL WALL BACKING FOR ALL WALL MOUNTED ITEMS, INCLUDING BUT NOT LIMITED TO THE FOLLOWING: DOOR STOPS, FIXTURES, WALL CABINETS, SHELVING, COUNTERS, TOILET ACCESSORIES, SECURITY EQUIPMENT, TACK BOARDS AND MARKER BOARDS, HAND RAILS AND WINDOW COVERING TRACKS.
7. SHOWER AND TUB ENCLOSURE DIMENSIONS VARY BY MANUFACTURER. COORDINATE FINAL SHOWER AND TUB SELECTION AND MANUFACTURER SIZING REQUIREMENTS PRIOR TO FRAMING.
8. WINDOW AND DOOR ROUGH OPENING REQUIREMENTS MAY VARY BY MANUFACTURER. COORDINATE FINAL OPENING REQUIREMENTS PER MANUFACTURER PRIOR TO FRAMING.
9. WORK SHOWN ON THESE DRAWINGS IS TO BE SUPPLIED, FURNISHED, CONSTRUCTED, INSTALLED ALL AS PER THE GENERAL CONDITIONS AND THE SPECIFICATIONS. EXCEPTIONS AS DESCRIBED BY THE FOLLOWING ABBREVIATIONS:
 - A. CFCI - CONTRACTOR FURNISHED - CONTRACTOR INSTALLED.
 - B. OFCI - OWNER FURNISHED - CONTRACTOR INSTALLED.
 - C. OFOI - OWNER FURNISHED - OWNER INSTALLED.
 - D. NIC OR N.I.C. - NOT IN CONTRACT OR NOT A PART OF THIS CONTRACT.

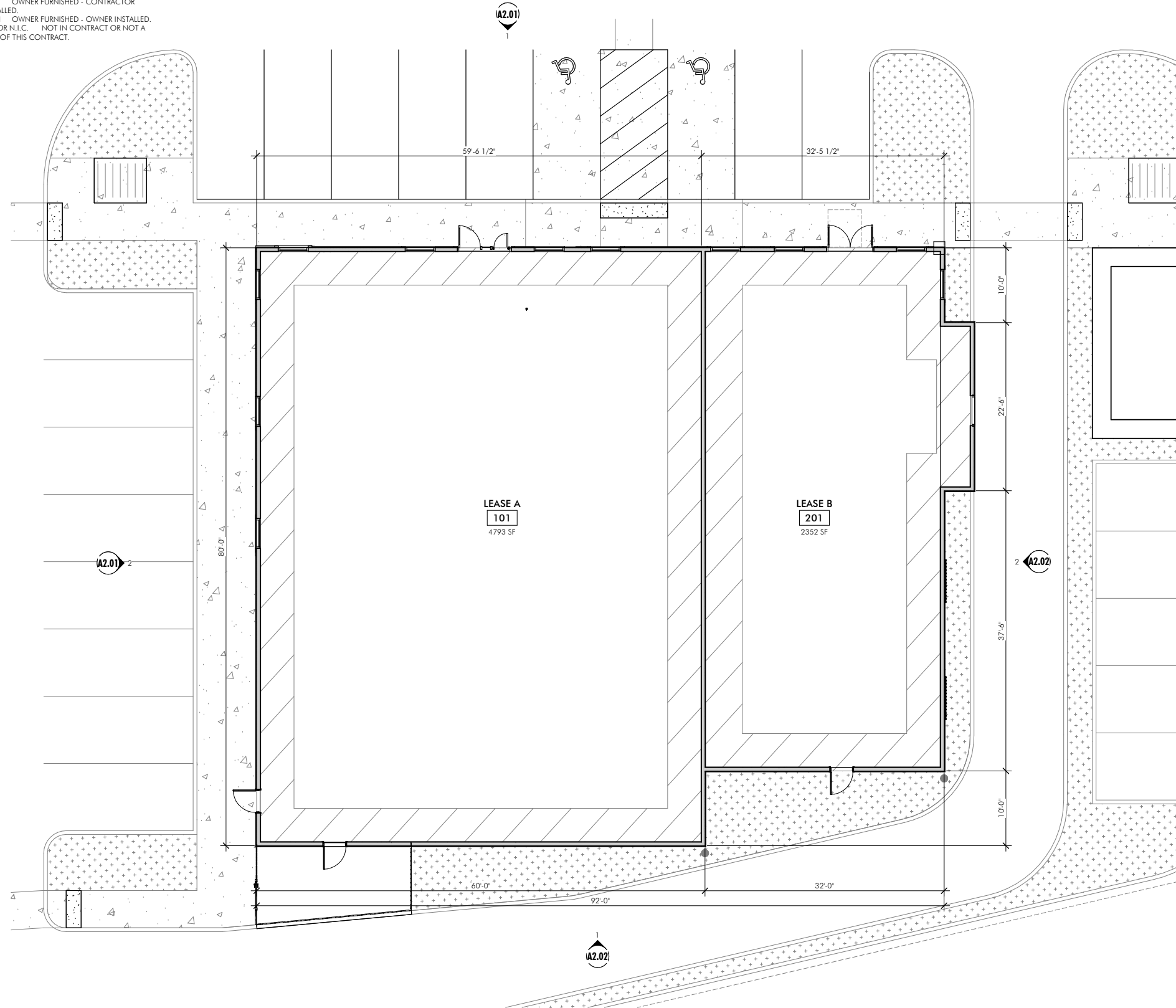

1 LEVEL 01 FLOOR PLAN
 0 2 4 8 16 24
 1/8" = 1'-0"

IN THE EVENT CONFLICTS ARE DISCOVERED BETWEEN THE ORIGINAL SIGNED AND SEALED DOCUMENTS PREPARED BY THE ARCHITECTS AND/OR THEIR CONSULTANTS, AND ANY COPY OF THE DOCUMENTS TRANSMITTED BY MAIL, FAX, ELECTRONICALLY OR OTHERWISE, THE ORIGINAL SIGNED AND SEALED DOCUMENTS SHALL GOVERN.

PROJECT # 2022-156
DATE: 7/10/2023
REVISIONS

Baseline Retail
Cornelius, Oregon

SHEET:

A1.21

IN THE EVENT CONFLICTS ARE DISCOVERED
BETWEEN THE ORIGINAL SIGNED AND SEALED
DOCUMENTS PREPARED BY THE ARCHITECTS
AND/OR THEIR CONSULTANTS, AND ANY COPY OF
THE DOCUMENTS TRANSMITTED BY MAIL, FAX,
ELECTRONICALLY OR OTHERWISE, THE ORIGINAL
SIGNED AND SEALED DOCUMENTS SHALL GOVERN.

PROJECT # 2022-156
DATE: 7/10/2023
REVISIONS

ELEVATION NOTES:

- 1 PREFINISHED PROFILED METAL PANEL.
- 2 FIBER CEMENT LAP SIDING 7" EXPOSURE.
- 3 FIBER CEMENT TRIM BOARD. PAINT FINISH.
- 4 ALUMINUM STOREFRONT
- 5 PREFINISHED METAL FLASHING.
- 6 SIGNAGE PANEL PROVIDE POWER.
- 7 STEEL AWNING. POWDER COAT FINISH. PROVIDE (2) LED PUCK LIGHTS BELOW EACH AWNING.
- 8 STEEL LATTICE.
- 9 EXTERIOR WALL PACK LIGHT.

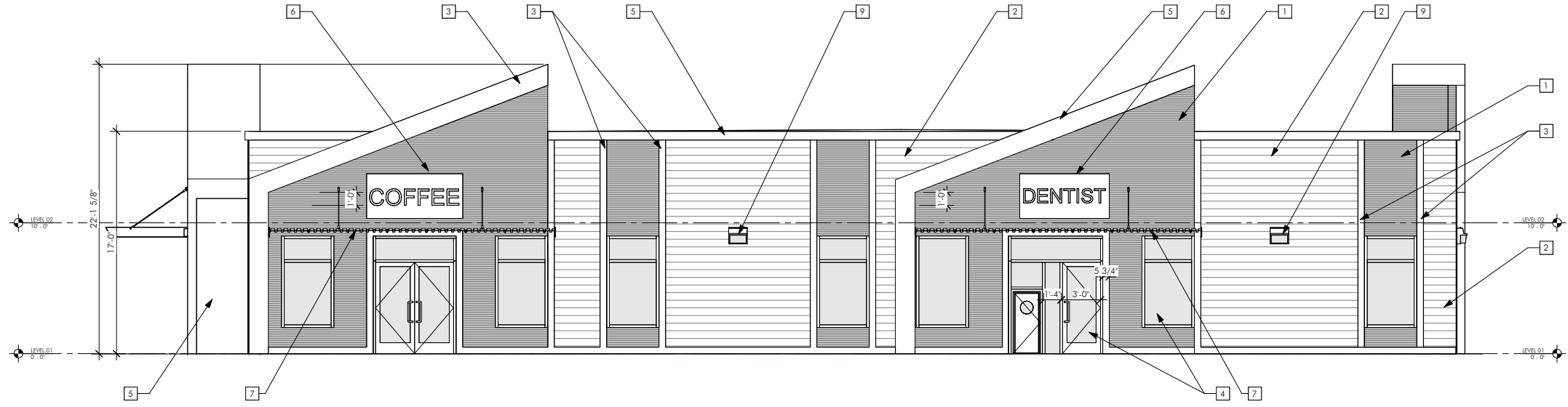

1 NORTH ELEVATION

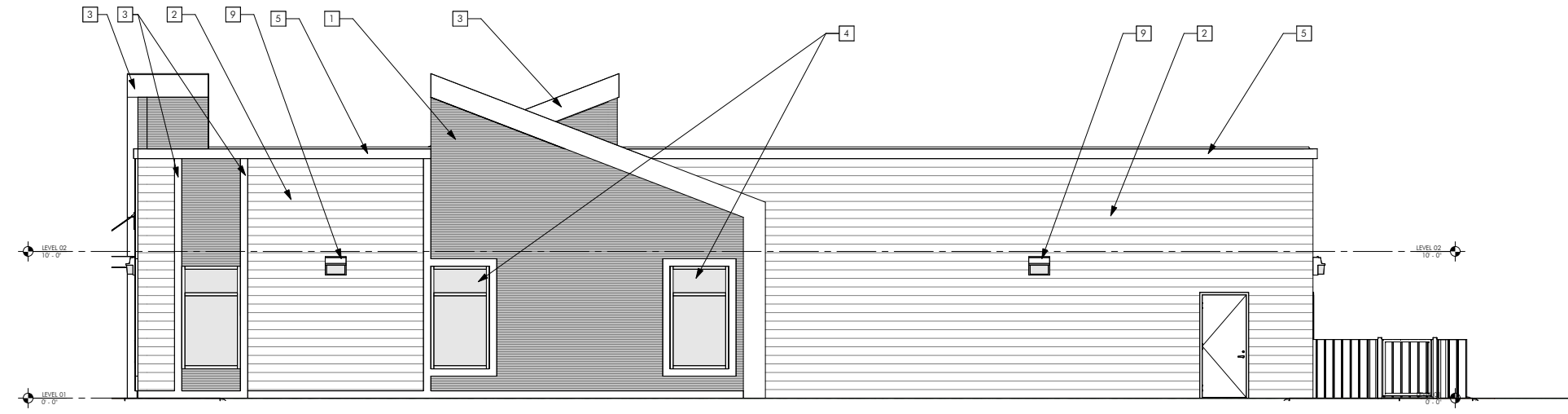
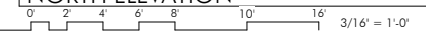

2 WEST ELEVATION

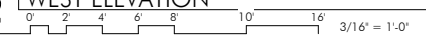

Baseline Retail
Cornelius, Oregon

IN THE EVENT CONFLICTS ARE DISCOVERED
BETWEEN THE ORIGINAL SIGNED AND SEALED
DOCUMENTS PREPARED BY THE ARCHITECTS
AND/OR THEIR CONSULTANTS, AND ANY COPY OF
THE DOCUMENTS TRANSMITTED BY MAIL, FAX,
ELECTRONICALLY OR OTHERWISE, THE ORIGINAL
SIGNED AND SEALED DOCUMENTS SHALL GOVERN.

PROJECT # 2022-156
DATE: 7/10/2023
REVISIONS

Baseline Retail
Cornelius, Oregon

ELEVATION NOTES:

- 1 PREFINISHED PROFILED METAL PANEL.
- 2 FIBER CEMENT LAP SIDING 7" EXPOSURE.
- 3 FIBER CEMENT TRIM BOARD, PAINT FINISH.
- 4 ALUMINUM STOREFRONT
- 5 PREFINISHED METAL FLASHING.
- 6 SIGNAGE PANEL PROVIDE POWER.
- 7 STEEL AWNING, POWDER COAT FINISH, PROVIDE (2) LED PLUCK LIGHTS BELOW EACH AWNING.
- 8 STEEL LATTICE.
- 9 EXTERIOR WALL PACK LIGHT.

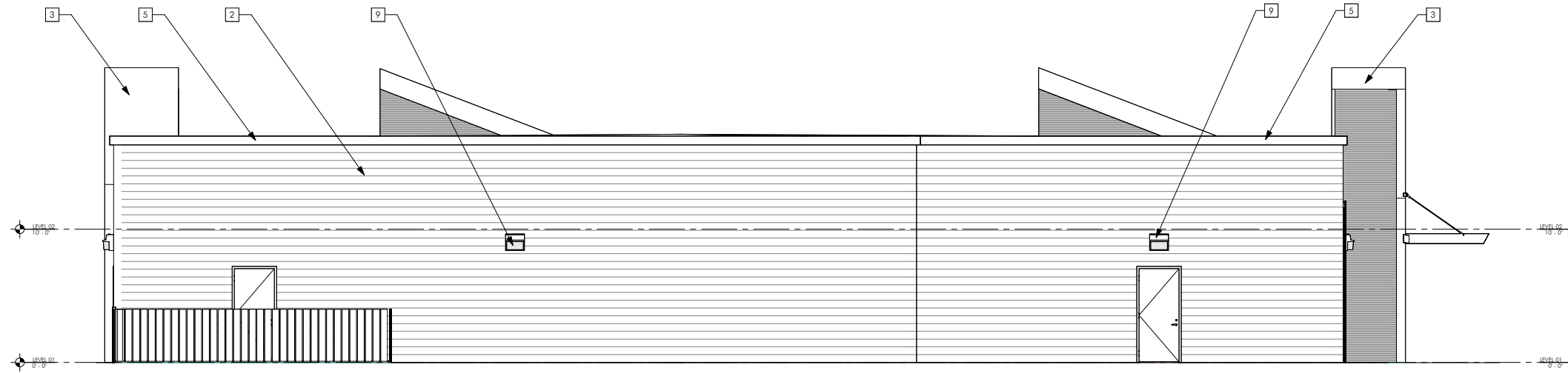

1 SOUTH ELEVATION

0' 2' 4' 6' 8' 10' 16' 3/16" = 1'-0"

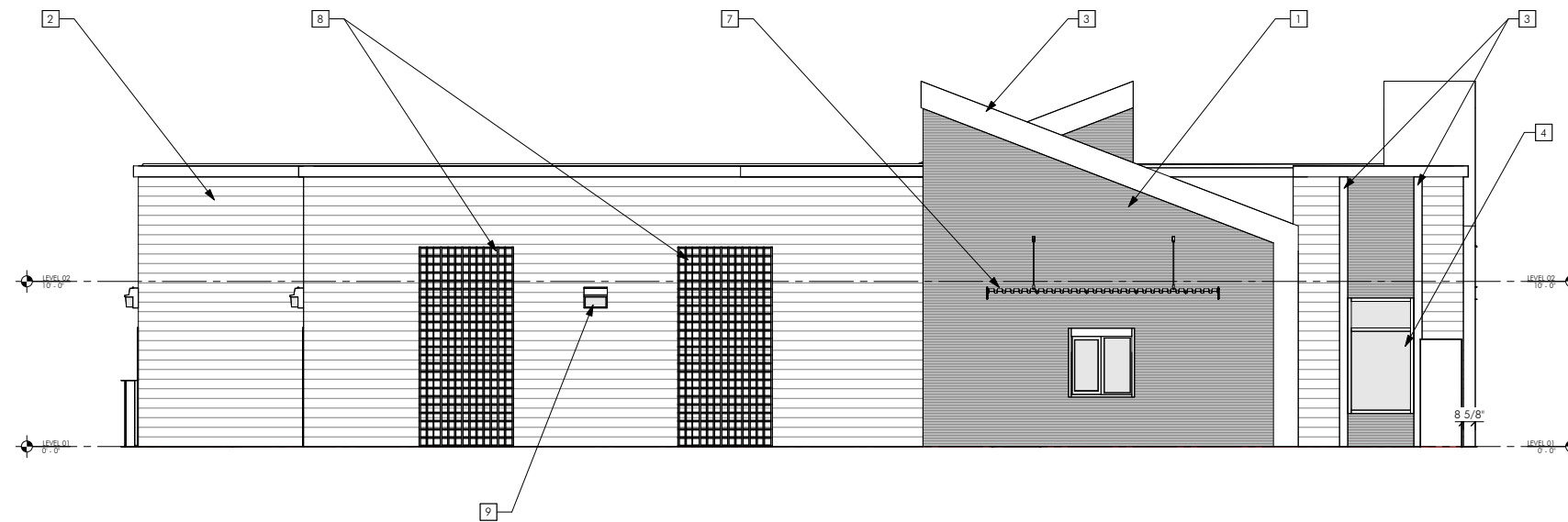

2 EAST ELEVATION

0' 2' 4' 6' 8' 10' 16' 3/16" = 1'-0"



**FIBER CEMENT PANEL SIDING
PAINT COLOR: SW 7069 IRON ORE**

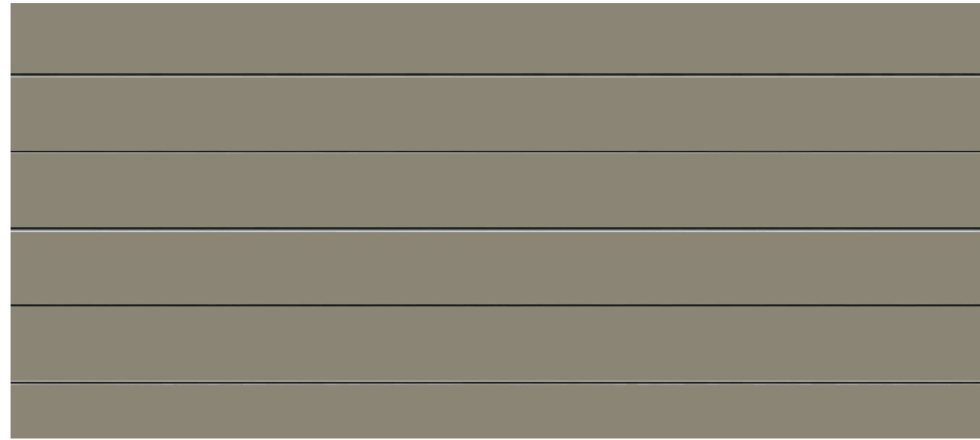

**FIBER CEMENT LAP SIDING, 7" REVEAL
PAINT COLOR: SW SW 7743 MOUNTAIN ROAD**

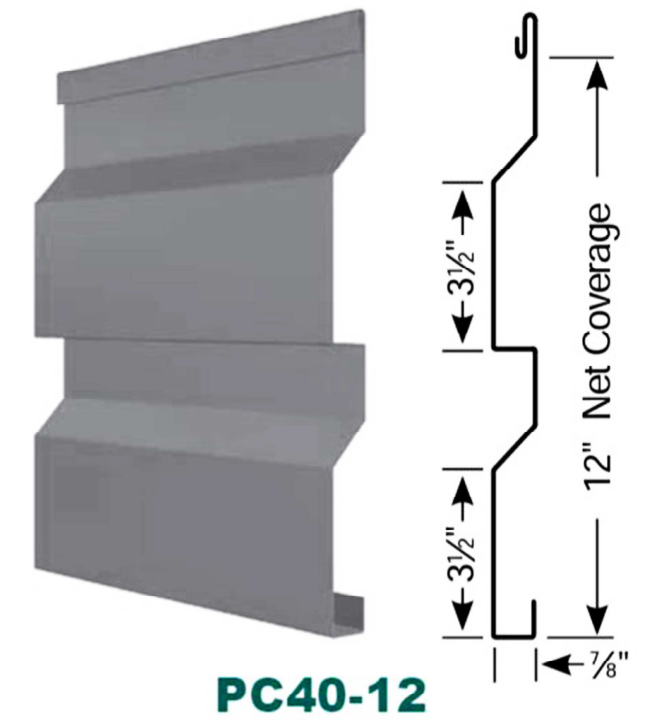

**PC40-12
PROFILED ALUMINUM SIDING**

**BASELINE RETAIL
SE CORNER OF S 1ST ST. AND W BASELINE ST.
Cornelius, Oregon 97113**



**ALUMINUM AND
GLASS STOREFRONT
AT RETAIL**



Exhibit B: Application Forms and Checklists (Updated September 2023)



Land Use Application

Community Development
Located at 1300 S. Kodiak Circle, Cornelius, Oregon 97113
www.ci.cornelius.or.us

OFFICIAL USE ONLY		
Date Received: _____	Date Complete: _____	↓ File Number ↓
Application Fee: _____	Receipt Number: _____	_____

APPLICATION TYPE

Type I – administrative review without public notice

- | | | |
|--|---|--|
| <input type="checkbox"/> Design Review I | <input type="checkbox"/> Lot Line Adjustment | <input type="checkbox"/> Administrative Relief |
| <input type="checkbox"/> Land Partition—Final Plat | <input type="checkbox"/> Subdivision—Final Plat | |
| <input type="checkbox"/> Other <i>please describe:</i> _____ | | |

Type II – administrative review with public notice

- | | | |
|--|---|---|
| <input type="checkbox"/> Design Review II | <input checked="" type="checkbox"/> Land Partition—Preliminary Plat | <input type="checkbox"/> Subdivision—Preliminary Plat |
| <input type="checkbox"/> Other <i>please describe:</i> _____ | | |

Type III – public hearing(s) required with public notice

- | | | |
|--|---|---|
| <input checked="" type="checkbox"/> Design Review III | <input type="checkbox"/> Conditional Use Permit | <input type="checkbox"/> Planned Unit Development |
| <input type="checkbox"/> Comprehensive Plan Amendment | <input type="checkbox"/> Zone Map Amendment | <input type="checkbox"/> Zone Text Amendment |
| <input type="checkbox"/> Annexation | <input type="checkbox"/> ROW/Easement Vacation | <input type="checkbox"/> Subdivision—Preliminary Plat |
| <input type="checkbox"/> Other <i>please describe:</i> _____ | | |

APPLICANT INFORMATION

Name: Nathan Palmer Signature:

Mail Address: 200 E Palm Valley Dr, Suite 1080, Oviedo, FL, 32765

Phone: Please contact applicant's consultant Fax: Please contact applicant's consultant E-mail: Please contact applicant's consultant

PROPERTY OWNER INFORMATION

Name: Ann Snyder Tilden, Trustee Richard H. Tilden Administrative Trust Signature: DocuSigned by: Ann Snyder Tilden

Mail Address: 6865 SW Canyon Drive, Portland, OR 97225 2FF509251D254E6... 7/31/2023

Phone: Please contact applicant's consultant Fax: Please contact applicant's consultant E-mail: Please contact applicant's consultant

SUBJECT SITE INFORMATION

Property Address: No situs; lot at the intersection of S 1st Avenue and W Baseline Street

Map & Tax Lot Number(s): Map 1S304BB, Tax Lot 300

Current Zoning: Highway Commercial (C-2) Total Size of Site: ±2.32 acres

Existing Use: N/A; vacant lot

Proposed Use: Mixed-use commercial (dentist's office, drive-through coffee shop)

Applicant's Consultant:
Melissa Slotemaker, AICP
AKS Engineering & Forestry
12965 SW Herman Road, Ste. 100
Tualatin, OR 97062
(503)-563-6151
slotemakerm@aks-eng.com

Revised April 2017

**LAND PARTITION (Preliminary Plat)
Written Narrative Requirements**



A. **Checklist:** Please provide one completed and signed copy of this four page checklist.



B. **Description of proposal:** Please describe what the existing conditions are on-site and the changes proposed to the site, structure, landscaping, parking, and land use, including the number of parcels created. Provide findings verifying that the intended use is allowed by the City's *Development Code*.



C. **Approval criteria findings:** Please provide a narrative that evaluates and verifies the proposal meets the approval criteria identified below:

Section 17.05.030(C) of the Development Code

1. *The proposal conforms with the City's Comprehensive Plan.*

Please note when making findings, the applicant shall address all applicable Comprehensive Plan policies.

2. *The proposal complies with all applicable statutory and ordinance requirements.*

Please note when making findings, the applicant shall address all applicable Development Code requirements. Specify conformance or proposed variance request from the requirements of the Development.

3. *Adequate public facilities are available to serve the proposal; and*

4. *All proposed lots conform to the size and dimensional requirements of this ordinance; and*

5. *All proposed improvements meet City standards.*

Section 18.155 of the Development Code

1. If the subject parcel is located in the R-10 or R-7 the proposal shall meet the Solar Access Protection design standards identified in *Section 18.155* The applicant will state which option, exemption or both is chosen and describe how it complies.



D. **Additional Requirements:** Please be advised that special studies, investigations and reports may be required to ensure that the proposal does not adversely affect the surrounding community, does not create hazardous conditions for persons or improvements on the site. These studies may include investigations and reports on noise attenuation, air quality, traffic control, soil conditions, flooding of waters and storm water run-off, natural resources, tree preservation, and other concerns.

N/A

- E. **Fee Ownership:** If applying for a Fee Ownership Land Division please Provide findings specifically addressing each of the approval criteria found in *Section 17.05.050*, of the City's *Development Code*. The criteria below are required in addition to the evaluation of the Land Partition criteria.
1. *As a whole, the development of which the unit is a part meets ordinance criteria for lot area, lot dimensions, setbacks, parking, lot coverage, landscaping, public facilities and street frontage.*
 2. *The development as a whole, the unit for which fee ownership is desired and any unit affected by the division shall meet all building, plumbing and fire code standards.*
 3. *Ingress and egress is provided to all lots.*
 4. *Parking is provided in accordance with ordinance standard for the individual unit either on the new lot or through easements as described in subsection 6, below. If assigned parking is provided, it shall meet ordinance standards.*
 5. *Adequate public facilities are provided to the new lot.*
 6. *The applicant provides deed covenants required that address: parking, maintenance of buildings and utilities, landscaping and common areas, ingress and egress. The deed covenants must be approved by the City Attorney and Planning Director.*



- F. **Sensitive Area Pre-Screening Site Assessment Letter:** Please provide a copy a completed and signed Sensitive Area Pre-Screening Site Assessment Letter from the City of Cornelius City Engineer.

Plan Requirements

All plans shall be presented at a minimum scale of 1" = 20', and on a maximum sheet size of 24" x 36". Please include all of the following information on the plan.

- A. **Existing Conditions Plan** includes the following:
- 1. North arrow, scale and date of plan.
 - 2. Vicinity map.
 - 3. All existing and proposed lot sizes, lot lines and dimensions.
 - 4. Points of existing access, interior streets, driveways, and parking areas.
 - 5. Location of all existing buildings and structures, including refuse storage locations and pedestrian/bike paths.
 - 6. Existing right-of-way and improvements, including sidewalk dimensions.
 - N/A 7. Dimension from right-of-way centerline to edge of existing property line and to required right-of-way dedication.
 - 8. Dimensions of all improvements, including setbacks.
 - 9. Location of existing public and private utilities, and 100-year floodplain.
 - 10. Topographical information, (2 ft. contour lines) of existing grades.
- B. **Proposed Preliminary Plat** includes the following:
- 1. Location, widths and names of all existing, proposed streets and public ways within or adjacent to the plat. Illustrate easements for utilities, other encumbrances and railroad right-of-ways. New streets shall be designated with proposed street names.
 - N/A 2. Dimension from right-of-way centerline to edge of existing property line and to required right-of-way dedication.
 - 3. Location of existing and proposed easements.
 - 4. Location of at least one temporary bench mark within the plat boundaries.
 - 5. Square footage of all proposed lots.
 - 6. The total gross acreage of the partition plat.
 - 7. Identify and label on the plat conformance with the Solar Ordinance requirements.
- C. **Preliminary Plat Reduction** includes the following:
- 1. Provide one proposed preliminary plat reduced to 8.5" x 11".
- D. **Proposed Improvement Plan** includes the following:
- 1. North arrow, scale and date of plan.
 - 2. All proposed lot sizes, lot lines and dimensions.
 - N/A 3. Dimension from right-of-way centerline to edge of existing and proposed property line and to required right-of-way dedication.
 - 4. Existing and proposed right-of-way and improvements, including sidewalk dimensions.
 - 5. Topographical information, (2 ft. contour lines) of existing and proposed grades.
 - 6. Location of proposed public and private utilities, proposed easements, and 100-year floodplain.



- 7. Plans and profiles of proposed sanitary and storm sewers, showing that gravity service is feasible for all lots.
- 8. Cross-section of all street and bike path improvements.



E. **Landscape Plan:**



- 1. Submit proposed landscaping of water quality, water quantity, wetland mitigation, common space and other non-buildable tracts. Plantings of water quality or quantity facilities shall be designed in accord with Clean Water Services (CWS) standard plant list.

I have provided the items required in this four page submittal checklist. I understand that any missing information, omissions or both may deem my project incomplete, which may lengthen the time to process the request.

Melissa Slotemaker
 Print name

 Signature



503-563-6151 / 503-563-6152
 Telephone Number /FAX Number
9/18/23
 Date

Community Development

Located at 1300 S. Kodiak Circle, Cornelius, Oregon 97113

www.ci.cornelius.or.us

Written Narrative Requirements

-  A. **Checklist.** Please provide one completed copy of this six-page checklist.
-  B. **Description of proposal.** Please describe what changes are proposed to the site, structure, landscaping, parking, and land use. Provide findings verifying that the intended use is allowed by the City's *Development Code* (Chapter 18).
-  C. **Approval criteria findings:** Please provide findings verifying that the proposal meets the Code's requirements found in *Section 18.100*, Land Use & Zoning Site Design Review, Development Requirements & Standards of the applicable zone, and the off-street parking and loading requirements of *Section 18.145.*, in addition, provide findings for any other applicable Code requirements. Specify conformance or proposed variance request from those requirements.
-  D. **Technical and design standards.** Please provide findings specifically addressing each criteria found in *Section 18.100.040* of the City's *Development Code* (Chapter 18).
-  E. **Proposed Operations:** Please provide the hours of operation, total number of employees, and maximum number of employees per shift.
-  F. **Additional Requirements:** Please be advised that special studies, investigations and reports may be required to ensure that the proposal does not adversely affect the surrounding community, and does not create hazardous conditions for persons or improvements on the site. These studies may include investigations and reports on noise attenuation, air quality, traffic control, soil conditions, flooding of waters and storm water run-off, natural resources, tree preservation, and other concerns.

Written Narrative Requirements (cont.)

<u>✓</u>	<p>G. <u>Site Analysis Information:</u></p> <p>1. Existing building area: <u>0</u> sq. ft. Proposed building addition or subtraction: <u>7,100</u> sq. ft.</p> <p>2. Existing building height: <u>0</u> ft. Proposed building height: <u>22</u> ft.</p> <p>3. Existing parking area: <u>0</u> sq. ft. Existing number of parking spaces: <u>0</u> # sp. Proposed parking addition or subtraction: <u>14,940</u> sq. ft. Proposed number of parking spaces: <u>83</u> # sp. Proposed use: <u>Medical office/drive-through restaurant</u> Parking requirement: <u>N/A</u></p> <p>4. Existing landscaped area: <u>0</u> sq. ft. Percentage of site: <u>0</u> % Proposed landscape addition or subtraction: <u>13,600</u> sq. ft. Percentage of site: <u>13</u> %</p>
----------	--

- | | |
|----------|--|
| <u>✓</u> | <p>H. <u>Neighborhood Review Meeting:</u> information required (<i>Dev. Code Section 18.10.030.</i>). (Only required for Type III Reviews)</p> |
| <u>✓</u> | <p>1. A copy of the notice sent to surrounding property owners.</p> |
| <u>✓</u> | <p>2. A copy of the mailing list used to send out meeting notices.</p> |
| <u>✓</u> | <p>3. An affidavit of mailing notice.</p> |
| <u>✓</u> | <p>4. Representative copies of written materials and plans presented at the Neighborhood Review Meeting.</p> |
| <u>✓</u> | <p>5. Notes of the meeting, including the meeting date, time, and location, the names and addresses of those who attended, and oral and written comments received.</p> |

<u>✓</u>	<p>I. <u>Other Requirements:</u> Please provide documentation that the requirements from other agencies and/or jurisdictions for your proposal have been permitted OR submit your schedule for application and approval of the required permits. If applicable, include a copy of a signed Sensitive Area Pre-Screening Letter from the City Engineer. Based upon the findings of the Sensitive Area Pre-Screening Letter, a Clean Water Services Service Provider Letter may be required.</p>
----------	--

<u>N/A</u>	<p>J. <u>Temporary Construction Office.</u> Please provide information on the site plan showing the location and state the duration of the temporary construction office.</p>
------------	--

DESIGN REVIEW TYPE II & III

Plan Requirements

All plans, except architectural elevations, shall be presented at a minimum of 1" = 20' engineering scale and on a maximum sheet size of 24" x 36." Please also include one 'unbound' set that is 8 1/2" x 11" in size. Each of the following plans and drawings shall be submitted on separate sheets. Architectural elevations may be presented at an architectural scale. Please include all of the following information.

-  ✓ A. **Existing Conditions Plan:**
-  1. North arrow, scale and date of plan.
 -  2. Vicinity map.
 -  3. The entire lot(s), including area and property lines dimensioned.
 -  4. Points of existing access, interior streets, driveways, and parking areas.
 -  5. Location of all existing buildings and structures.
 -  6. Existing right-of-way and improvements.
 -  7. Dimension from centerline to edge of existing right-of-way.
 -  8. Existing topographical information, showing 2 ft. contours.
 -  9. Surrounding development and conditions within 100 ft. of the property; such as zoning, land uses, buildings, driveways, and trees.
 -  10. Location of existing public and private utilities, easements, and 100-year floodplain.
 -  11. Sensitive areas, as defined by the Clean Water Services standards.
 -  12. Wetland boundaries, upland wooded area boundaries, riparian area boundaries, rock out-croppings, and streams. *Wetlands must be professionally delineated.*
 -  13. Existing trees larger than 6" in dbh (diameter at breast height), including genus, species and size. Dbh is measured at 54" above grade.
-  B. **Dimensioned Site Plan:**
-  1. North arrow, scale and date of plan.
 -  2. The entire lot(s), including area, property lines dimensioned and labeled "front," "side," and "rear."
 -  3. Proposed points of access, interior streets, driveways, and parking areas.
 -  4. Proposed location of buildings and structures, including refuse storage locations, pedestrian/bike paths, swimming pools, tennis courts, and tot-lots.
 -  5. Proposed right-of-way, dedications and improvements.
 -  6. Dimension from centerline to edge of proposed right-of-way.
 -  7. Dimensions of all improvements, including setbacks, parking spaces, driveways, and distance between buildings.
 -  8. Location of storm water quality/detention facilities.
 -  9. Boundaries of development phases, if applicable.
 -  10. Sensitive areas, as defined by the Clean Water Services standards.



11. Wetland boundaries, upland wooded area boundaries, riparian area boundaries, rock out-croppings, and streams. *Wetlands must be professionally delineated.*



C.

Grading Plan:



1. North arrow, scale and date of plan.



2. The entire lot(s).



3. Points of access, interior streets, driveways, and parking areas.



4. Location of buildings and structures, including refuse storage locations, pedestrian/bike paths, swimming pools, tennis courts, and tot-lots.



5. Proposed rights-of-way, dedications and improvements.



6. Dimension from centerline to edge of proposed right-of-way.



7. Existing and proposed topographical information, showing 2 ft. contours and appropriate spot elevations for features such as walls, retaining walls (top and bottom elevations), catch basins, stairs, sidewalks, and parking areas.



8. Location of 100-year flood plain.



9. Location of storm water quality/detention facilities.



10. Boundaries of development phases, if applicable.



11. Natural Resource Areas, Significant trees, and Historic trees, if applicable.



12. Sensitive areas, as defined by the Clean Water Services standards.

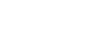

13. Wetland boundaries, upland wooded area boundaries, riparian area boundaries, rock out-croppings, and streams. *Wetlands must be professionally delineated.*



14. Existing trees larger than 6" dbh. Indicate which trees are proposed to be saved and which are proposed to be removed.



D.

Utility Plan:



1. North arrow, scale and date of plan.



2. The entire lot(s).



3. Points of access, interior streets, driveways, and parking areas.



4. Location of buildings and structures, including refuse storage locations, pedestrian/bike paths, swimming pools, tennis courts, and tot lots.



5. Proposed right-of-way, dedications and improvements.



6. Proposed topographical information, showing 2 ft. contours.



7. Location of 100-year flood plain.



8. Location of existing and proposed public and private utilities, easements, surface water drainage patterns, and storm water quality/detention facilities.









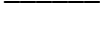







9. Boundaries of development phases, if applicable.









10. Sensitive areas, as defined by the Clean Water Services standards.



11. Wetland boundaries, upland wooded area boundaries, riparian area boundaries, rock out-croppings, and streams. *Wetlands must be professionally delineated.*

-  ✓ E. **Landscape Plan:**
-  1. North arrow, scale and date of plan.
 -  2. The entire lot(s).
 -  3. Points of access, interior streets, driveways, and parking areas.
 -  4. Location of buildings and structures, including refuse storage locations, pedestrian/bike paths, swimming pools, tennis courts, and tot lots.
 -  5. Proposed right-of-way, dedications and improvements.
 -  6. Boundaries of development phases, if applicable.
 -  7. Sensitive areas, as defined by the Clean Water Services standards.
 -  8. Wetland boundaries, upland wooded area boundaries, riparian area boundaries, rock out-croppings, and streams. *Wetlands must be professionally delineated.*
 -  9. Existing trees, larger than 6" dbh, proposed to be saved. Include genus, species, and size.
 -  10. The location and design of proposed landscaped areas, indicating all plant materials, including genus, species, common name, plant sizes, and spacing.
 -  11. List of plant materials, including genus, species, common name, size, quantity, spacing and condition.
 -  12. Other pertinent landscape features, including walls, retaining walls, berms, fences, and fountains.
 -  13. A note on the plan indicating that an irrigation system will be installed to maintain the landscape materials.

-  ✓ F. **Lighting Plan:**
-  1. Location of all exterior lighting, including those mounted on poles, walls, bollards and the ground.
 -  2. Type, style, height, and the number of fixtures per light.
 -  3. Wattage per fixture and lamp type, such as sodium, mercury, and halide.
 -  4. 8 ½" x 11" manufacturer's illustrations and specifications (cut sheets) of all proposed lighting poles and fixtures.
 -  5. For all exterior lighting, indicate the area and pattern of illumination measured at ½-foot candlepower.

-  ✓ G. **Architectural Renderings and Elevations, or both:** Please provide information that identifies the general character of the buildings and structures; indicate dimensions, materials, colors, and textures proposed for any structures. This includes buildings, retaining walls, refuse storage facilities, play structures, and fences

-  ✓ H. **Materials Board:** Please provide one 8½" x 11" or 8½" x 14" Materials Board with examples of all building materials, colors, and textures of exterior surfaces.

I have provided the items required in this six-page submittal checklist. I understand that any missing information, omissions or both may deem my project incomplete, which may lengthen the time to process the request.



9/18/2023

Signature

Date

Melissa Slotemaker, AICP

503-563-6151

Print Name

Telephone Number

Exhibit C: Ownership Information



FIRST AMERICAN TITLE

Property Research Report

SUBJECT PROPERTY

Ns
R409962
1S304BB00300
Washington

OWNER

Tilden, Richard H Rev Trust & Tilden, Ann Snyder

DATE PREPARED

Date: 05/11/2023

PREPARED BY

gparilla@firstam.com



First American Title

Customer Service Department
503.219.8746
cs.oregon@firstam.com

©2018 First American Financial Corporation and/or its affiliates.

All rights reserved. | NYSE: FAF | 39203000418

IMPORTANT – READ CAREFULLY: THIS REPORT IS NOT AN INSURED PRODUCT OR SERVICE OR A REPRESENTATION OF THE CONDITION OF TITLE TO REAL PROPERTY. IT IS NOT AN ABSTRACT, LEGAL OPINION, OPINION OF TITLE, TITLE INSURANCE COMMITMENT OR PRELIMINARY REPORT, OR ANY FORM OF TITLE INSURANCE OR GUARANTY. THIS REPORT IS ISSUED EXCLUSIVELY FOR THE BENEFIT OF THE APPLICANT THEREFOR, AND MAY NOT BE USED OR RELIED UPON BY ANY OTHER PERSON. THIS REPORT MAY NOT BE REPRODUCED IN ANY MANNER WITHOUT FIRST AMERICAN'S PRIOR WRITTEN CONSENT. FIRST AMERICAN DOES NOT REPRESENT OR WARRANT THAT THE INFORMATION HEREIN IS COMPLETE OR FREE FROM ERROR, AND THE INFORMATION HEREIN IS PROVIDED WITHOUT ANY WARRANTIES OF ANY KIND, AS-IS, AND WITH ALL FAULTS. AS A MATERIAL PART OF THE CONSIDERATION GIVEN IN EXCHANGE FOR THE ISSUANCE OF THIS REPORT, RECIPIENT AGREES THAT FIRST AMERICAN'S SOLE LIABILITY FOR ANY LOSS OR DAMAGE CAUSED BY AN ERROR OR OMISSION DUE TO INACCURATE INFORMATION OR NEGLIGENCE IN PREPARING THIS REPORT SHALL BE LIMITED TO THE FEE CHARGED FOR THE REPORT, IF ANY. RECIPIENT ACCEPTS THIS REPORT WITH THIS LIMITATION AND AGREES THAT FIRST AMERICAN WOULD NOT HAVE ISSUED THIS REPORT BUT FOR THE LIMITATION OF LIABILITY DESCRIBED ABOVE. FIRST AMERICAN MAKES NO REPRESENTATION OR WARRANTY AS TO THE LEGALITY OR PROPRIETY OF RECIPIENT'S USE OF THE INFORMATION HEREIN.



First American Title

Customer Service Department
503.219.8746
cs.oregon@firstam.com
Date: 05/11/2023

OWNERSHIP INFORMATION

Owner: Tilden, Richard H Rev Trust & Tilden, Ann Snyder Rev Trust

Parcel #: R409962

CoOwner:

Ref Parcel #: 1S304BB00300

Site: Ns Cornelius OR 97113

TRS: 01S / 03W / 04 / NW

Mail: PO Box 25404 Portland OR 97298

County: Washington

PROPERTY DESCRIPTION

Map Grid: 592-D5
Census Tract: 032902 Block: 2004
Neighborhood: CPO12C - Cpo 12 Cornelius
School Dist: 15 Forest Grove
Impr Type:
Subdiv/Plat: Cornelius Environs
Land Use: 2200
Std Land Use: CMSC - Commercial Miscellaneous
Zoning: Cornelius-C2 - Community Commercial
Lat/Lon: 45.51967535 / -123.06974386
Watershed: Scoggins Creek-Tualatin River
Legal: CORNELIUS ENVIRONS, LOT PT 10, ACRES
2.32

ASSESSMENT AND TAXATION

Market Land: \$1,176,330.00
Market Impr: \$0.00
Market Total: \$1,176,330.00 (2022)
% Improved: 0.00%
Assessed Total: \$329,130.00 (2022)
Levy Code: 15.38
Tax: \$5,207.20 (2022)
Millage Rate: 15.8211
Exemption:
Exemption Type:

PROPERTY CHARACTERISTICS

Bedrooms:	Total SqFt:	Year Built:
Baths, Total:	First Floor:	Eff Year Built:
Baths, Full:	Second Floor:	Lot Size Ac: 2.32 Acres
Baths, Half:	Basement Fin:	Lot Size SF: 101,059 SqFt
Total Units:	Basement Unfin:	Lot Width:
# Stories:	Basement Total:	Lot Depth:
# Fireplaces:	Attic Fin:	Roof Material:
Cooling:	Attic Unfin:	Roof Shape:
Heating:	Attic Total:	Ext Walls:
Building Style:	Garage:	Const Type:

SALES AND LOAN INFORMATION

Owner	Date	Doc #	Sale Price	Deed Type	Loan Amt	Loan Type
DEPARTMENT OF TRANSPORTATION	02/01/2022	7930		Deed		Conv/Unk
DEPARTMENT OF TRANSPORTATION	02/01/2022	7931		Quit Claim		Conv/Unk
RICHARD H TILDEN	10/29/1998	121072		Deed		Conv/Unk
TILDEN RICHARD H TRUST PT	10/29/1998	121073		Deed		Conv/Unk
TILDEN ANN S TRUST PT	10/29/1998	121074		Deed		Conv/Unk
RICHARD ANN TILDEN				Deed		Conv/Unk

Sentry Dynamics, Inc. and its customers make no representations, warranties or conditions, express or implied, as to the accuracy or completeness of information contained in this report.

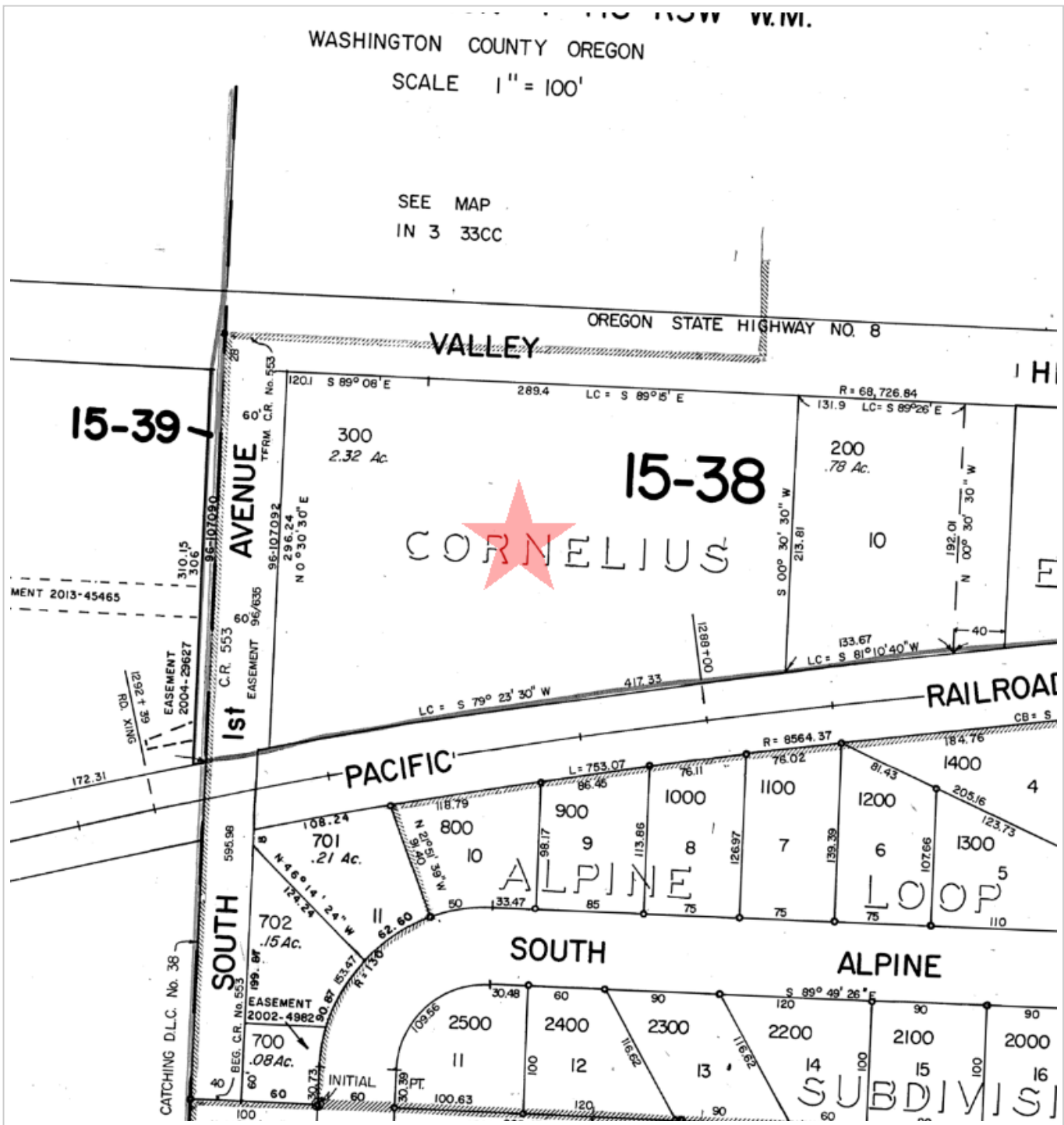

First American Title

Parcel ID: R409962

Site Address: Ns

Sentry Dynamics, Inc. and its customers make no representations, warranties or conditions, express or implied, as to the accuracy or completeness of information contained in this report.

Aerial Map



First American Title

Parcel ID: R409962

Sentry Dynamics, Inc. and its customers make no representations, warranties or conditions, express or implied, as to the accuracy or completeness of information contained in this report.

STATE OF OREGON }
County of Washington } SS

I, Jerry R. Hanson, Director of Assessment and Taxation and Ex-Officio County Clerk for said county, do hereby certify that the within instrument of writing was received and recorded in book of records of said county.

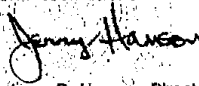
Jerry R. Hanson, Director of
Assessment and Taxation, Ex-
Officio County Clerk

Doc : 98121074
Rect: 219624 41.00
10/29/1998 10:02:06am

1-3

8615

FILED FOR RECORD AT REQUEST OF/
AFTER RECORDING RETURN TO:

Christine P. Brown, Esq.
Garvey, Schubert & Barer
Eleventh Floor
121 S.W. Morrison Street
Portland, Oregon 97204

UNTIL A CHANGE IS REQUESTED, ALL
TAX STATEMENTS SHALL BE SENT TO
THE FOLLOWING ADDRESS:

Ann Snyder Tilden and Richard H. Tilden
Trustees of the Ann Snyder Tilden
Revocable Trust, U/A Dated 9/8/98
6865 SW Canyon Drive
Portland, Oregon 97225

WARRANTY DEED

KNOW ALL MEN BY THESE PRESENTS, that Ann Snyder Tilden, individually, hereinafter called Grantor, for and in consideration other than money or money's worth, grants, bargains, sells and conveys to Ann Snyder Tilden and Richard H. Tilden, as Trustees of the Ann Snyder Tilden Revocable Trust under agreement dated September 8, 1998, hereinafter called the Grantee, and unto Grantee and Grantee's successors and assigns, any and all of her interest in all of that certain real property with the tenements, hereditaments and appurtenances thereunto belonging or in any way appertaining, situated in the County of Washington, State of Oregon, described as follows:

Beginning at a point on the south line of the Tualatin Valley Highway eastbound, which point bears South 00°30'30" West 28.0 feet and South 89°08' East 40.0 feet from the northwest corner of Lot 10, CORNELIUS ENVIRONS, a subdivision of record in Washington County, Oregon, and running thence along said highway line, South 89°08' East 120.1 feet and on a 68,726.84 curve left (the long chord of which bears South 89°15' East) 289.4 feet, thence South 00°30'30" West 213.81 feet to the northern line of the Southern Pacific Company's Right of Way; thence along said northerly line, on a 8,624.37 foot curve left (the long chord of which bears South 79°23'30" West) 417.33 feet; thence North 00°30'30" East, parallel with the west line of said Lot 10, 296.24 feet to the point of beginning.

To have and to hold the same unto the Grantee and Grantee's successors and assigns forever.

The Grantor hereby covenants to and with Grantee and Grantee's, successors and assigns, that Grantor is lawfully seized in fee simple of the above granted premises, free from all encumbrances, except those of record as of the date this deed is signed, and that Grantor will warrant and forever defend the

GRANTOR:
Ann Snyder Tilden
6865 SW Canyon Drive
Portland, Oregon 97225

GRANTEE:
Ann Snyder Tilden and Richard H. Tilden
Trustees of the Ann Snyder Tilden Revocable
Trust, U/A Dated September 8, 1998
6865 SW Canyon Drive
Portland, Oregon 97225

Warranty Deed Page 1 of 2

Deed No. 3 Record Third

Transaction Title Insurance
Accommodation Recording 9806427

premises and every part and parcel thereof against the lawful claims and demands of all persons whomsoever, except those claiming under the above described encumbrances.

The liability and obligations of the Grantor to Grantee and Grantee's heirs and assigns under the warranties and covenants contained herein or provided by law shall be limited to the extent of coverage that would be available to Grantor under a standard policy of title insurance. The limitations contained herein expressly do not relieve Grantor of any liability or obligations under this instrument, but merely define the scope, nature, and amount of such liability or obligations.

In construing this deed, where the context so requires, the singular includes the plural and all grammatical changes shall be made so that this deed shall apply equally to corporations and to individuals.

IN WITNESS WHEREOF, the Grantor has executed this instrument on the date set forth below; if a corporate Grantor, it has caused its name to be signed and its seal, if any, affixed by an officer or other person duly authorized to do so by order of its board of directors.

THIS INSTRUMENT WILL NOT ALLOW USE OF THE PROPERTY DESCRIBED IN THIS INSTRUMENT IN VIOLATION OF APPLICABLE LAND USE LAWS AND REGULATIONS. BEFORE SIGNING OR ACCEPTING THIS INSTRUMENT, THE PERSON ACQUIRING FEE TITLE TO THE PROPERTY SHOULD CHECK WITH THE APPROPRIATE CITY OR COUNTY PLANNING DEPARTMENT TO VERIFY APPROVED USES AND TO DETERMINE ANY LIMITS ON LAWSUITS AGAINST FARMING OR FOREST PRACTICES AS DEFINED IN ORS 30.930.

DATED this 21st day of October, 1998.

Ann Snyder Tilden, Grantor

STATE OF OREGON)
) ss.
County of Washington)

This instrument was acknowledged before me on October 21st, 1998 by Ann Snyder Tilden.

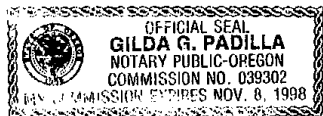



Notary Public for Oregon

Exhibit D: Washington County Assessor's Map

WASHINGTON COUNTY OREGON

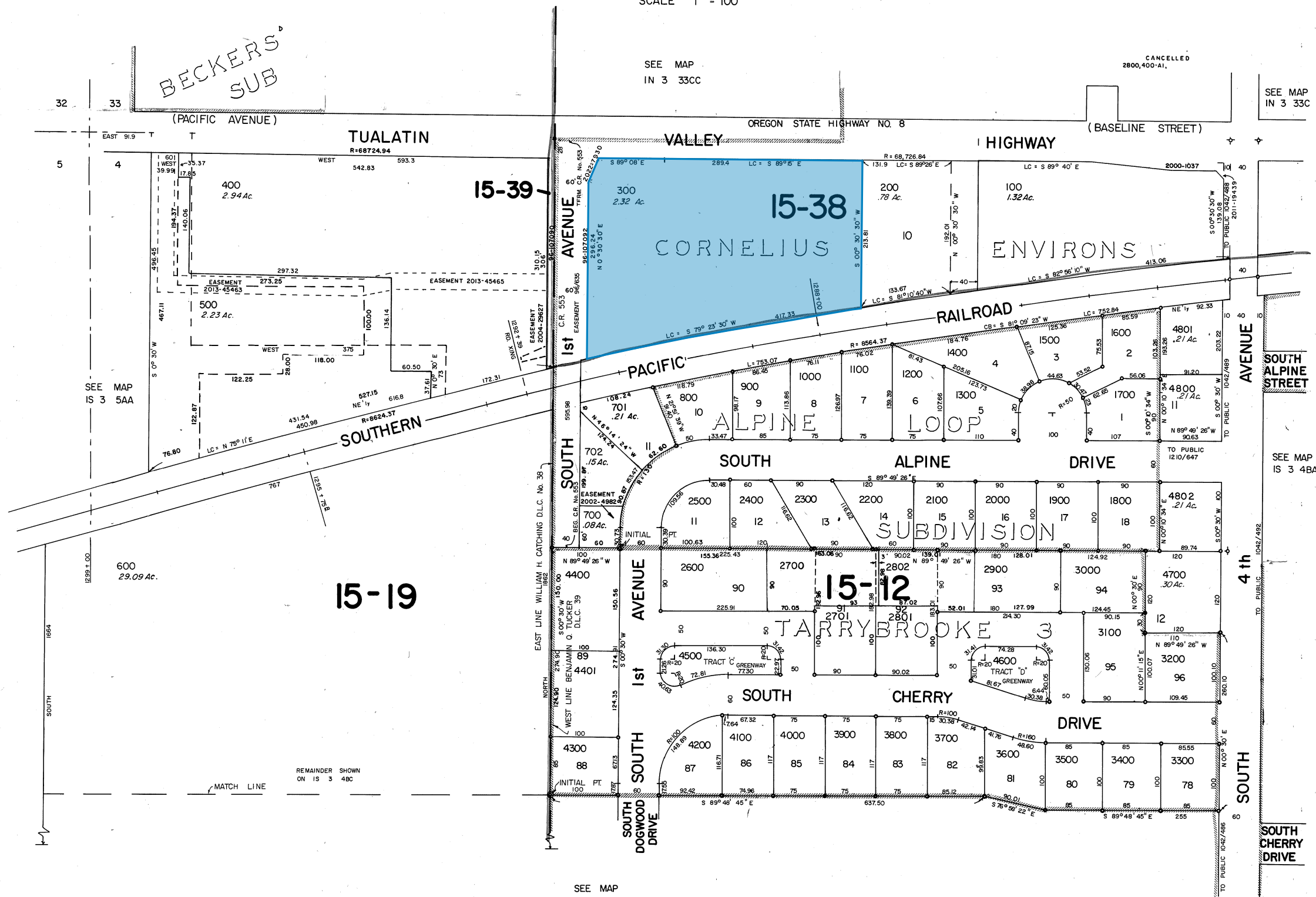
SCALE 1" = 100'



BECKER'S SUB

SEE MAP IN 3 33C

CANCELLED 2800,400-A1,

SEE MAP IN 3 33C

SEE MAP IS 3 5AA

SEE MAP IS 3 4BA

SEE MAP IS 3 4BC

FOR ASSESSMENT PURPOSES ONLY DO NOT RELY ON FOR ANY OTHER USE

CORNELIUS FOREST GROVE IS 3 4BB

D. Moore 3-14-28

Exhibit E: Clean Water Services Service Provider Letter

Service Provider Letter

This form and the attached conditions will serve as your Service Provider Letter in accordance with Clean Water Services Design and Construction Standards (R&O 19-5, as amended by R&O 19-22).

Jurisdiction:	<u>City of Cornelius</u>	Review Type:	<u>Allowed Use</u>
Site Address / Location:	<u>S 1st Ave/Baseline St</u> <u>Cornelius 97113</u>	SPL Issue Date:	<u>July 17, 2023</u>
		SPL Expiration Date:	<u>July 16, 2025</u>

Applicant Information:

Name NATHAN PALMER
 Company _____
 Address 200 E PALM VALLEY DR, SUITE 1080
OVIEDO, FL 32765
 Phone/Fax (614) 586-3303
 E-mail: npalmer@leadersre.com

Owner Information:

Name _____
 Company _____
 Address _____
 Phone/Fax _____
 E-mail: _____

Tax lot ID

1S304BB00300

Development Activity

Commercial Development

Pre-Development Site Conditions:

Sensitive Area Present: On-Site Off-Site
 Vegetated Corridor Width: 50
 Vegetated Corridor Condition: Degraded

Post Development Site Conditions:

Sensitive Area Present: On-Site Off-Site
 Vegetated Corridor Width: 50

Enhancement of Remaining Vegetated Corridor Required:

Square Footage to be enhanced:

15,694

Encroachments into Pre-Development Vegetated Corridor:

Type and location of Encroachment:	Square Footage:
<u>Stormwater Pipe (Temporary Encroachment; Restoration Planting In-Place Required)</u>	<u>232</u>
<u>Stormwater Outfall (Permanent Encroachment; No Mitigation Required)</u>	<u>70</u>

Mitigation Requirements:

Type/Location	Sq. Ft./Ratio/Cost
_____	_____
_____	_____
_____	_____

Conditions Attached Development Figures Attached () Planting Plan Attached Geotech Report Required

This Service Provider Letter does NOT eliminate the need to evaluate and protect water quality sensitive areas if they are subsequently discovered on your property.

In order to comply with Clean Water Services water quality protection requirements the project must comply with the following conditions:

1. No structures, development, construction activities, gardens, lawns, application of chemicals, uncontained areas of hazardous materials as defined by Oregon Department of Environmental Quality, pet wastes, dumping of materials of any kind, or other activities shall be permitted within the sensitive area or Vegetated Corridor which may negatively impact water quality, except those allowed in R&O 19-5, Chapter 3, as amended by R&O 19-22.
2. Prior to any site clearing, grading or construction the Vegetated Corridor and water quality sensitive areas shall be surveyed, staked, and temporarily fenced per approved plan. During construction the Vegetated Corridor shall remain fenced and undisturbed except as allowed by R&O 19-5, Section 3.06.1, as amended by R&O 19-22 and per approved plans.
3. **If there is any activity within the sensitive area, the applicant shall gain authorization for the project from the Oregon Department of State Lands (DSL) and US Army Corps of Engineers (USACE). The applicant shall provide Clean Water Services or its designee (appropriate city) with copies of all DSL and USACE project authorization permits. No wetland impacts proposed for this project.**
4. An approved Oregon Department of Forestry Notification is required for one or more trees harvested for sale, trade, or barter, on any non-federal lands within the State of Oregon.
5. Prior to any ground disturbing activities, an erosion control permit is required. Appropriate Best Management Practices (BMP's) for Erosion Control, in accordance with Clean Water Services' Erosion Prevention and Sediment Control Planning and Design Manual, shall be used prior to, during, and following earth disturbing activities.
6. Prior to construction, a Stormwater Connection Permit from Clean Water Services or its designee is required pursuant to Ordinance 27, Section 4.B.
7. Activities located within the 100-year floodplain shall comply with R&O 19-5, Section 5.10, as amended by R&O 19-22.
8. Removal of native, woody vegetation shall be limited to the greatest extent practicable.
9. The water quality swale and detention pond shall be planted with Clean Water Services approved native species, and designed to blend into the natural surroundings.
10. **Should final development plans differ significantly from those submitted for review by Clean Water Services, the applicant shall provide updated drawings, and if necessary, obtain a revised Service Provider Letter.**
11. The Vegetated Corridor width for sensitive areas within the project site shall be a minimum of 50 feet wide, as measured horizontally from the delineated boundary of the sensitive area.
12. **For Vegetated Corridors up to 50 feet wide, the applicant shall enhance the entire Vegetated Corridor to meet or exceed good corridor condition as defined in R&O 19-5, Section 3.14.2, Table 3-3, as amended by R&O 19-22.**
13. Prior to any site clearing, grading or construction, the applicant shall provide Clean Water Services with a Vegetated Corridor enhancement/restoration plan. Enhancement/restoration of the Vegetated Corridor shall be provided in accordance with R&O 19-5, Appendix A, as amended by R&O 19-22, and shall include planting specifications for all Vegetated Corridor, including any cleared areas larger than 25 square feet in Vegetated Corridor rated ""good.""
14. Prior to installation of plant materials, all invasive vegetation within the Vegetated Corridor shall be removed per methods described in Clean Water Services' Integrated Pest Management Plan, 2019. During removal of invasive vegetation care shall be taken to minimize impacts to existing native tree and shrub species.
15. Clean Water Services and/or City shall be notified 72 hours prior to the start and completion of enhancement/restoration activities. Enhancement/restoration activities shall comply with the guidelines provided in Planting Requirements (R&O 19-5, Appendix A, as amended by R&O 19-22).

- 16. Maintenance and monitoring requirements shall comply with R&O 19-5, Section 2.12.2, as amended by R&O 19-22. If at any time during the warranty period the landscaping falls below the 80% survival level, the owner shall reinstall all deficient planting at the next appropriate planting opportunity and the two year maintenance period shall begin again from the date of replanting.
- 17. Performance assurances for the Vegetated Corridor shall comply with R&O 19-5, Section 2.07.2, Table 2-1 and Section 2.11, Table 2-2, as amended by R&O 19-22.
- 18. Clean Water Services shall require an easement over the Sensitive Area and Vegetated Corridor conveying storm and surface water management to Clean Water Services or the City that would prevent the owner of the Vegetated Corridor from activities and uses inconsistent with the purpose of the corridor and any easements therein.

FINAL PLANS

- 19. **Final construction plans shall include landscape plans.** In the details section of the plans, a description of the methods for removal and control of exotic species, location, distribution, condition and size of plantings, existing plants and trees to be preserved, and installation methods for plant materials is required. Plantings shall be tagged for dormant season identification and shall remain on plant material after planting for monitoring purposes.
- 20. **A Maintenance Plan shall be included on final plans** including methods, responsible party contact information, and dates (minimum two times per year, by June 1 and September 30).
- 21. **Final construction plans shall clearly depict the location and dimensions of the sensitive area and the Vegetated Corridor** (indicating good, marginal, or degraded condition). Sensitive area boundaries shall be marked in the field.
- 22. Protection of the Vegetated Corridors and associated sensitive areas shall be provided by the installation of permanent fencing and signage between the development and the outer limits of the Vegetated Corridors. **Fencing and signage details to be included on final construction plans.**





This Service Provider Letter is not valid unless CWS-approved site plan is attached.



**Stacy Benjamin
Environmental Plan Review**

Attachments (3)

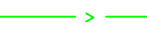
LEGEND (COLOR COPY):

-  ON-SITE PEM/SLOPE WETLAND A:
2,582 SF± (0.06 ACRES±)
-  DEGRADED CONDITION VEGETATED CORRIDOR AREA:
15,996 SF± (0.37 ACRES±)
-  TOTAL ON-SITE ROADSIDE DRAINAGE DITCH 1: 278 LF±
-  STW STORMWATER UTILITY LINE
-  PHOTO POINT AND ORIENTATION

WETLAND A SHOWN WAS DELINEATED BY AKS ENGINEERING & FORESTRY, LLC ON AUGUST 02, 2022 AND MAY 05, 2023 AND WAS LOCATED WITH SUB-METER ACCURACY USING A TRIMBLE GEO 7X HANDHELD GPS RECEIVER.

1-FOOT INTERVAL GROUND CONTOURS, EXISTING CONDITIONS, TREE SURVEY OF TREES >6" DBH, AND PROJECT AREA BOUNDARY DERIVED FROM AKS LAND SURVEY ON SEPTEMBER 01 AND 02, 2022 WITH SUB-METER ACCURACY.

CWS FILE NO. 23-001847
 Approved
 Clean Water Services
 FOR ENVIRONMENTAL REVIEW
 By SNB Date 7/17/2023
 SPL ATTACHMENT 1 OF 3

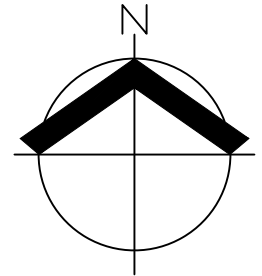
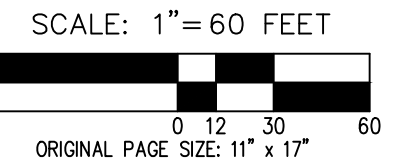
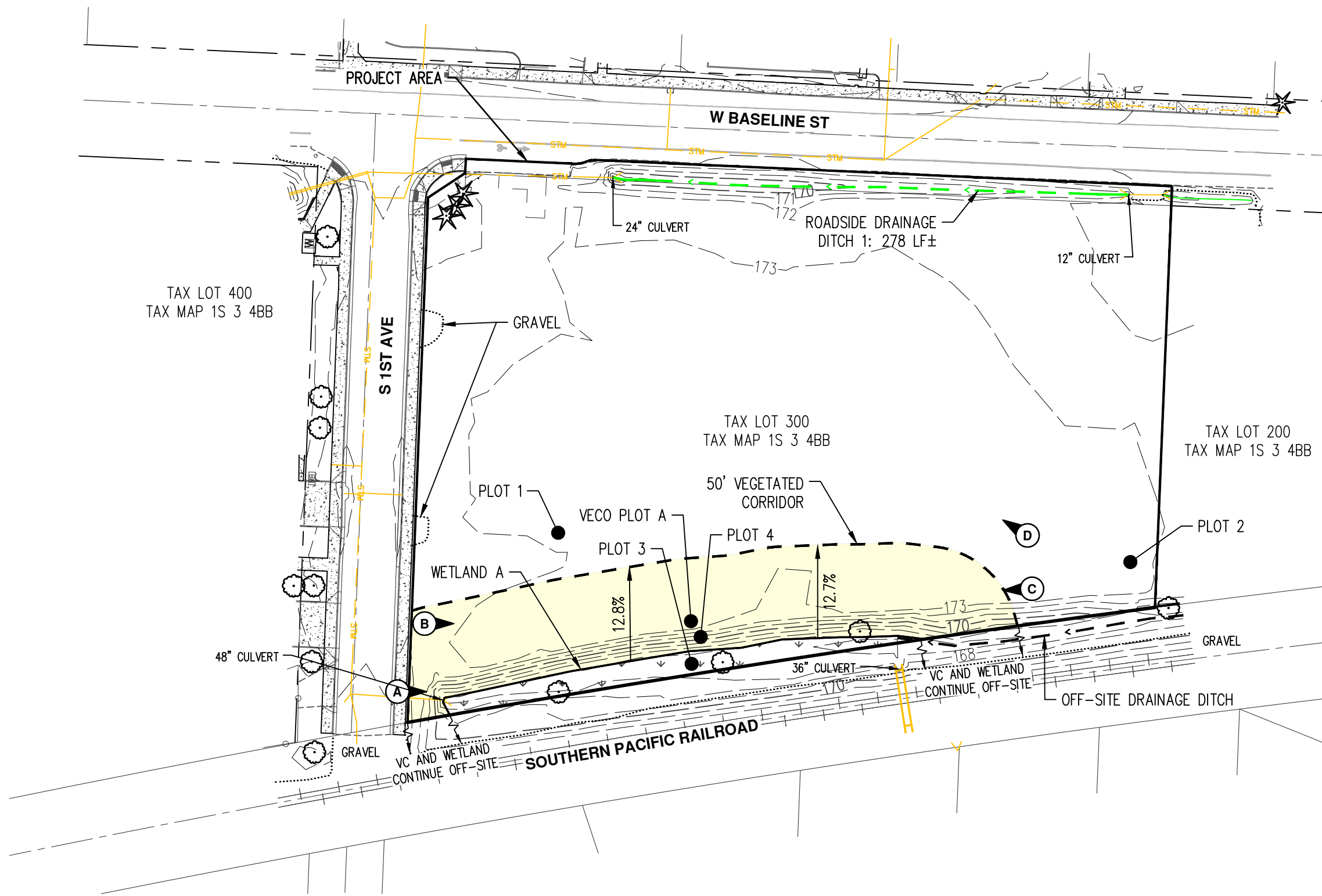

DATE: 06/16/2023



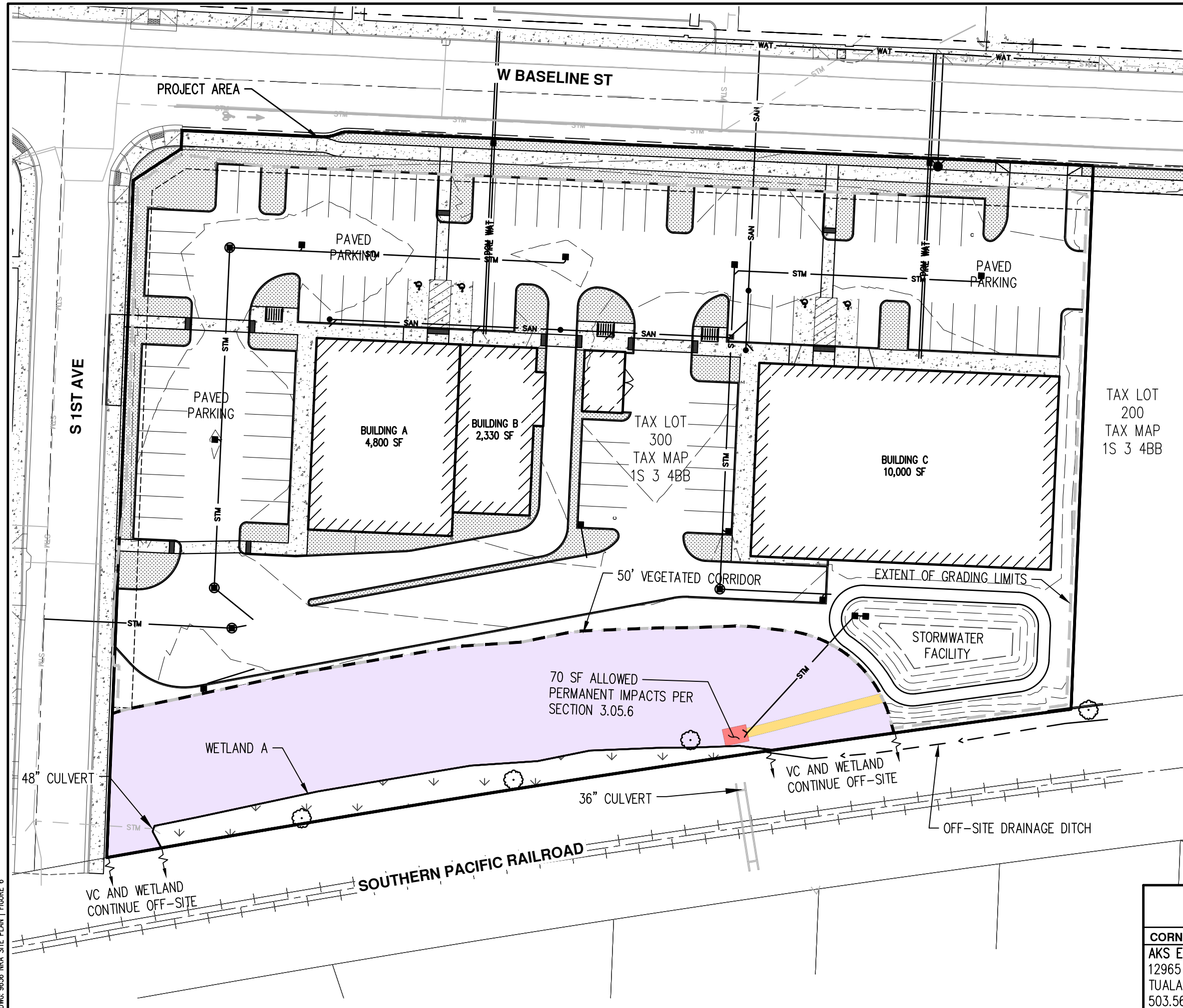

NATURAL RECOURCES EXISTING CONDITIONS	FIGURE
CORNELIUS SOUTH COMMERCIAL SITE ASSESSMENT REPORT	5
AKS ENGINEERING & FORESTRY, LLC 12965 SW HERMAN RD, STE 100 TUALATIN, OR 97062 503.563.6151 WWW.AKS-ENG.COM	DRWN: GPM CHKD: RAS AKS JOB: 9656





CWS FILE NO. 23-001847
 Approved
 Clean Water Services
 FOR ENVIRONMENTAL REVIEW
 By SNB Date 7/17/2023
 SPL ATTACHMENT 2 OF 3

LEGEND (COLOR COPY):

-  PEM/SLOPE WETLAND A AREA TO REMAIN: 2,582 SF± (0.06 ACRES±)
-  DEGRADED CONDITION VEGETATED CORRIDOR TO BE ENHANCED TO GOOD CONDITION: 15,694 SF± (0.36 ACRES±)
-  TEMPORARY VEGETATED CORRIDOR IMPACT AREA TO BE RESTORED TO GOOD CONDITION: 232 SF± (0.01 ACRES±)
-  PERMANENT VEGETATED CORRIDOR IMPACT AREA: 70 SF±

WETLAND A SHOWN WAS DELINEATED BY AKS ENGINEERING & FORESTRY, LLC ON AUGUST 02, 2022 AND MAY 05, 2023 AND WERE LOCATED WITH SUB-METER ACCURACY USING A TRIMBLE GEO 7X HANDHELD GPS RECEIVER.

SCALE: 1" = 40 FEET



ORIGINAL PAGE SIZE: 11" x 17"

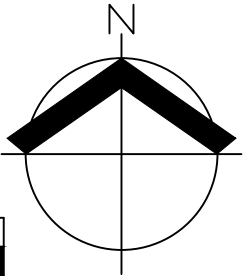

DATE: 06/16/2023

NATURAL RECOURCES SITE PLAN		FIGURE
CORNELIUS SOUTH COMMERCIAL SITE ASSESSMENT REPORT		6
AKS ENGINEERING & FORESTRY, LLC 12965 SW HERMAN RD, STE 100 TUALATIN, OR 97062 503.563.6151 WWW.AKS-ENG.COM		DRWN: RAS CHKD: SKT AKS JOB: 9656

DMC: 9656 NRA SITE PLAN | FIGURE 6

Cornelius South Commercial Vegetated Corridor Planting Specifications

Planting specifications for ±232 square feet of temporary vegetated corridor encroachment to be replanted in place, and ±15,694 square feet of enhancement of the *degraded* condition vegetated corridor to *good* condition.

Total planting area ±15,926 square feet

TEMPORARY ENCROACHMENT REPLANTING AREA (+232 square feet)

Scientific Name	Common Name	Size*	Spacing/Seeding Rate	Quantity
Shrubs (total 12)**				
<i>Holodiscus discolor</i>	Oceanspray	1 gallon	4-5 feet on center	3
<i>Crataegus douglasii</i>	Douglas hawthorn	1 gallon	4-5 feet on center	3
<i>Rosa gymnocarpa</i>	Baldhip rose	1 gallon	4-5 feet on center	2
<i>Mahonia aquifolium</i>	Tall Oregon grape	1 gallon	4-5 feet on center	2
<i>Symphoricarpos albus</i>	Snowberry	1 gallon	4-5 feet on center	2
Seed Mix				
<i>Bromus carinatus</i>	native California brome	seed	1 lb/acre	As needed for bare soil areas >25 square feet
<i>Festuca roemerii</i>	Roemer's fescue	seed	1 lb/acre	

*Bare root plants may be substituted for container plants based on availability. If bare root plants are used, they must be planted during the late winter/early spring dormancy period.

**Minimum quantities to be planted.

DEGRADED VEGETATED CORRIDOR ENHANCMENT AREA (+15,694 square feet)

Scientific Name	Common Name	Size*	Spacing/Seeding Rate	Quantity
Trees (total 157)**				
<i>Pseudotsuga menziesii</i>	Douglas-fir	1 gallon	10 feet on center	79
<i>Acer macrophyllum</i>	bigleaf maple	1 gallon	10 feet on center	78
Shrubs (total 785)**				
<i>Holodiscus discolor</i>	Oceanspray	1 gallon	4-5 feet on center	157
<i>Crataegus douglasii</i>	Douglas hawthorn	1 gallon	4-5 feet on center	157
<i>Rosa gymnocarpa</i>	Baldhip rose	1 gallon	4-5 feet on center	157
<i>Mahonia aquifolium</i>	Tall Oregon grape	1 gallon	4-5 feet on center	157
<i>Symphoricarpos albus</i>	Snowberry	1 gallon	4-5 feet on center	157
Seed Mix				
<i>Bromus carinatus</i>	native California brome	seed	1 lb/acre	As needed for bare soil areas >25 square feet
<i>Festuca roemerii</i>	Roemer's fescue	seed	1 lb/acre	

*Bare root plants may be substituted for container plants based on availability. If bare root plants are used, they must be planted during the late winter/early spring dormancy period.

**Minimum quantities to be planted.

CWS FILE NO. <u>23-001847</u>	
Approved Clean Water Services FOR ENVIRONMENTAL REVIEW	
By <u>SNB</u>	Date <u>7/17/2023</u>
SPL ATTACHMENT <u>3</u> OF <u>3</u>	

Exhibit F: Preliminary Stormwater Report

Cornelius South Commercial Cornelius, Oregon

Preliminary Stormwater Report

Date: July 2023

Client: Nathan Palmer
npalmer@leadersre.com

Engineering Contact: Cody Street
streetc@aks-eng.com

Engineering Firm: AKS Engineering & Forestry, LLC

AKS Job Number: 9656



RENEWAL DATE: 12/31/23



www.aks-eng.com

Table of Contents

1.0	Purpose of Report	1
2.0	Project Location/Description	1
3.0	Regulatory Design Criteria	1
3.1.	Stormwater Quantity	1
3.2.	Stormwater Hydromodification	2
3.3.	Stormwater Quality.....	2
4.0	Design Methodology	2
5.0	Design Parameters	2
5.1.	Design Storms	2
5.2.	Pre-Developed Site Conditions	3
5.2.1.	Site Topography	3
5.2.2.	Existing Land Use	3
5.3.	Soil Type	3
5.4.	Post-Developed Site Conditions.....	3
5.4.1.	Site Topography	3
5.4.2.	Proposed Land Use/Development	3
5.4.3.	Post-Developed Site Parameters	4
5.4.4.	Description of Off-Site Contributing Basins	4
6.0	Stormwater Analyses	4
6.1.	Proposed Stormwater Conduit Sizing and Inlet Spacing.....	4
6.2.	Proposed Water Quality Treatment	4
6.3.	Stormwater Hydromodification Management	4
6.4.	Stormwater Quantity Control Facility Design	5
6.5.	Downstream Analysis.....	5

Tables

Table 5-1:	Rainfall Intensities.....	3
Table 5-2:	Hydrologic Soil Group Ratings.....	3
Table 6-1:	Total Pre and Post Developed Flows.....	5

Figures

- Figure 1:** Site Vicinity Map
- Figure 2:** Pre-Developed Basin Delineation
- Figure 3:** Post-Developed Basin Delineation
- Figure 4:** Stormwater Treatment Map

Appendices

- Appendix A:** HydroCAD Reports for Pre-Developed Conditions Storm Events
- Appendix B:** HydroCAD Reports for Post-Developed Conditions Storm Events
- Appendix C:** Stormwater Quality Calculations
- Appendix D:** USDA-NRCS Soil Resource Report
- Appendix E:** TR55 Runoff Curve Numbers

Preliminary Stormwater Report

CORNELIUS SOUTH COMMERCIAL CORNELIUS, OREGON

1.0 Purpose of Report

The purpose of this report is to analyze the effects the proposed development will have on the existing and proposed stormwater conveyance system; document the criteria, methodology, and informational sources used to design the proposed stormwater system; and present the results of the preliminary hydraulic analysis.

2.0 Project Location/Description

The subject site is located at the southeast intersection of South 1st Avenue and West Baseline Street, in the city of Cornelius and consists of a 2.33-acre parcel (Washington County Tax Lot 300, 1S 3 4BB). The proposed project will develop the site as a partitioned commercial site with ±0.43 acres placed within a tract to preserve the vegetated corridor and wetland. This report will address the stormwater analysis for the improved area of this proposed development.

The proposed project will redevelop Tax Lot 300 into a tract and two parcels. Both parcels will be developed for commercial purposes including new parking lots, buildings, driveway, and associated utilities. The project will also include new street frontage along West Baseline Street as part of the City's planned improvements. Stormwater runoff from within the project boundary will be captured and conveyed to one of the two on-site detention systems. Other runoff within the West Baseline Street and South 1st Avenue rights-of-way will remain untreated and conveyed to the existing public stormwater system. For the purposes of this report, the two parcels within the project boundary will be referred to 1S-1 and 1S-2. The proposed private stormwater management systems will be designed to provide the required stormwater quality treatment and hydromodification requirements, per Clean Water Services standards.

3.0 Regulatory Design Criteria

3.1. Stormwater Quantity

Per *Clean Water Services (CWS) Design and Construction Standards Manual for Sanitary Sewer and Surface Water Management (R&O 19-05), Section 4.02.2, Water Quantity Control Requirements for Conveyance Capacity, criteria for requiring on-site detention for conveyance capacity (25-year storm event)* is required when any of the following conditions exist:

1. *There is an identified downstream deficiency, and the District or City determines that detention rather than conveyance system enlargement is the more effective solution.*
2. *There is an identified regional detention site within the boundary of the development.*
3. *Water quantity facilities are required by District-adopted watershed management plans or adopted subbasin master plans.*

On site stormwater quantity will be met by creating an underground detention system and a stormwater facility. The underground detention system and the stormwater facility have been sized to detain the post-developed storm event flow to the pre-developed 25-year storm event flow.

Further description of the on-site stormwater quantity management for the project is provided in Section 6.4 of this report. There is no increase of flow to the public storm drain infrastructure from the improvements.

3.2. Stormwater Hydromodification

Per CWS R&O 19-05 Section 4.03.2, *Hydromodification Assessment Requirement*, stormwater hydromodification is required unless the project meets any of the following criteria:

1. *The project results in the addition and/or modification of less than 12,000 square feet of impervious surface.*
2. *The project is located in an area with a District approved subbasin strategy with an identified regional stormwater management approach for hydromodification.*

Per listed criteria in the Hydromodification Approach Project Category Table 4-2, the project is identified as Category #2. Therefore, the project will meet CWS hydromodification requirements by providing peak-flow matching detention within a LIDA facility and an underground detention system, using the criteria established within CWS Section 4.08.6.

3.3. Stormwater Quality

Stormwater quality treatment for this project will be provided by a stormwater filter manhole prior to an underground detention system, located in 1S-1, and an extended dry detention basin, located within 1S-2. The stormwater facilities have been designed per CWS standards as established in CWS section 4.04.

4.0 Design Methodology

The Santa Barbara Urban Hydrograph (SBUH) Method was used to analyze stormwater runoff from the site. This method utilizes the SCS Type 1A 24-hour design storm. HydroCAD 10.0 computer software aided in the analysis. Representative CN numbers were obtained from the USDA-NCRS Technical Release 55 and are included in Appendix E.

5.0 Design Parameters

5.1. Design Storms

Per CWS requirements, the following rainfall intensities and durations were used in analyzing the proposed stormwater facility:

Recurrence Interval (Years)	Storm Period (hours)	Total Precipitation Depth (Inches)
WQ	4	0.36
2	24	2.50
5	24	3.10
10	24	3.45
25	24	3.90

5.2. Pre-Developed Site Conditions

5.2.1. Site Topography

Existing on-site grades generally vary from $\pm 0.5\%$ to $\pm 2.5\%$, aside from the $\pm 35.0\%$ to $\pm 50.0\%$ slopes within the wetland boundary. The site has a high point of ± 173.5 feet located in central-west side of the property and a low point of ± 167.0 feet located at the toe of the existing ditch within the wetland boundary near the south-east corner of the property. The site slopes radially from the central-west side of the site, draining to the north, south, east, and west.

5.2.2. Existing Land Use

The existing site consists of an agricultural field with straight row crops.

5.3. Soil Type

The soil beneath the project site and associated drainage basins is classified as Amity silt loam, Woodburn silt loam, and Verboort silt clay loam, according to the USDA Natural Resources Conservation Service (NRCS) Soil Survey for Washington County. The following table outlines the Hydrologic Soil Group rating for each soil type:

NRCS Map Unit Identification	NRCS Soil Classification	Hydrologic Soil Group Rating
2	Amity Silt Loam	C/D
45A	Woodburn Silt loam, 0%-3%	C
45B	Woodburn Silt Loam, 3%-7%	C
2027A	Verboort Silty Clay Loam, 0%-3%	D

Further information on this soil type is included in the NRCS Soil Resource Report located in Appendix D of this report.

5.4. Post-Developed Site Conditions

5.4.1. Site Topography

The portion of the subject site, to be developed as commercial, will be modified from the pre-developed site topography to allow for the construction of commercial buildings and associated parking lot, landscaped areas, utilities, and stormwater facilities. Additionally, portions of existing conditions within the West Baseline Street and South 1st Avenue rights-of-way will be modified.

5.4.2. Proposed Land Use/Development

The site land use will consist of two parcels for commercial purposes and a tract for preservation of the vegetated corridor and wetland.

5.4.3. Post-Developed Site Parameters

Appendix B provides the HydroCAD reports and input parameters that were used for the analyzed storm events with respect to the drainage basins contributing to the redeveloped site. These reports include all the parameters (e.g., impervious/pervious areas, time of concentration, etc.) used to model the site hydrology.

5.4.4. Description of Off-Site Contributing Basins

To the west of the subject site, there is an existing public stormwater main that conveys runoff from West Baseline Street, South 1st Avenue, and portions of properties north and west of the subject site. The existing offsite runoff will continue to be conveyed via the existing stormwater system that flows from West Baseline Street through South 1st Avenue.

6.0 Stormwater Analyses

6.1. Proposed Stormwater Conduit Sizing and Inlet Spacing

The proposed on-site catch basins will be spaced per City and CWS requirements to properly convey stormwater runoff. The proposed storm pipes will be sized to meet CWS sizing requirements using Manning's equation to convey the peak flows from the 25-year storm event.

6.2. Proposed Water Quality Treatment Clean Water Services [Onsite]

An extended dry basin and underground detention system have been designed per CWS *Design and Construction Standards Manual for Sanitary Sewer and Surface Water Management (R&O 19-5, as amended by R&O 19-22)*, Section 4.08 Stormwater Management Approach Sizing. The underground detention system will be preceded by a storm filter manhole that will provide water quality treatment for the impervious areas of 1S-1. The extended dry basin was sized to provide water quality treatment for the impervious areas of 1S-2.

The Water Quality Volume will be routed through the proposed water quality manhole and extended dry basin which will provide water quality treatment per CWS standards. Detailed calculations and checks against CWS criteria are included in the Appendices.

ODOT Public Right-of-Way [Offsite]

The improvements within the ODOT right-of-way add ±2,675 square feet of new impervious surface and ±6,782 square feet of modified impervious surface. The runoff from the improvements within the ODOT right-of-way drains into CWS jurisdiction, and CWS will require water quality management. The untreated area in the ODOT right-of-way will be addressed by paying CWS a fee-in-lieu of providing stormwater quality treatment.

6.3. Stormwater Hydromodification Management

The proposed project will generate ± 2.1 acres of impervious area, thus classifying as a large project. Per CWS Hydromod Planning Tool, the subject site is located within a developed region, discharging into a low risk level existing basin. Based on these parameters and CWS Table 4-2, the project classifies as Category 2 Hydromodification Approach.

Per Category 2, the subject site will provide peak flow matching detention, using design criteria as found in CWS Section 4.08.6, utilizing an approved LIDA stormwater facility and underground detention system. Specifically, the subject site post-developed 2, 5, and 10-year storm event runoff flows will not exceed the

site pre-developed 50% of 2, 5, and 10-year storm event flows. Table 6-1 summarizes the pre and post developed flows from the site. Detailed calculations are included in Appendix A-C of this report.

6.4. Stormwater Quantity Control Facility Design

The proposed project provides stormwater quantity management for the development by utilizing an underground storage facility and extended dry basin, both designed per CWS standards. The following table outlines the results of the total outflow of the site, which limits the post-development peak flows to less than or equal to the allowable pre-development peak flows for each storm event as outlined within CWS stormwater detention and hydromodification management requirements.

Recurrence Interval (Years)	Peak Pre-Development Flows (cfs)	Peak Post-Development Flows (cfs)*	Peak Flow Increase or (Decrease) – (cfs)
2	*0.23	0.23	0.00
5	0.73	0.43	(0.31)
10	0.89	0.65	(0.25)
25	1.10	0.95	(0.16)

*The peak pre-development flow for the 2-year storm event is 0.46 cfs, therefore 50% of the 2-year peak flow is 0.23 cfs.

The proposed underground detention system has sufficient capacity to detain the required post-developed flows to the allowable pre-developed flows and meets the requirements established by CWS (R&O 19-05). The proposed extended dry basin has sufficient capacity to detain the required post-developed flows to the allowable pre-developed flows and meets the requirements established by CWS (R&O 19-05). The extended dry basin has been designed per CWS requirements with 1-foot freeboard, during the 25-year storm event, and a permanent pool storage depth of 0.2 feet.

6.5. Downstream Analysis

The stormwater runoff from 1S-1 and 1S-2, along with the offsite runoff, will be conveyed to the existing public stormwater main on South 1st Avenue. This public stormwater main directs flow to an existing 36" bypass pipe constructed to redirect flows from north of the Pacific Railroad to Heather Street. A review of the 25-year design storm event was performed utilizing the SBUH method. The SBUH analysis indicates a net decrease (-0.16 cfs) in peak flow during the 25-year storm event under post-developed conditions. Therefore, the existing stormwater network downstream of the project site is expected to be adequate. A visual investigation of the downstream system was conducted to a distance of one-quarter mile downstream and there are no observable downstream impacts to structures.

Figure 1: Site Vicinity Map

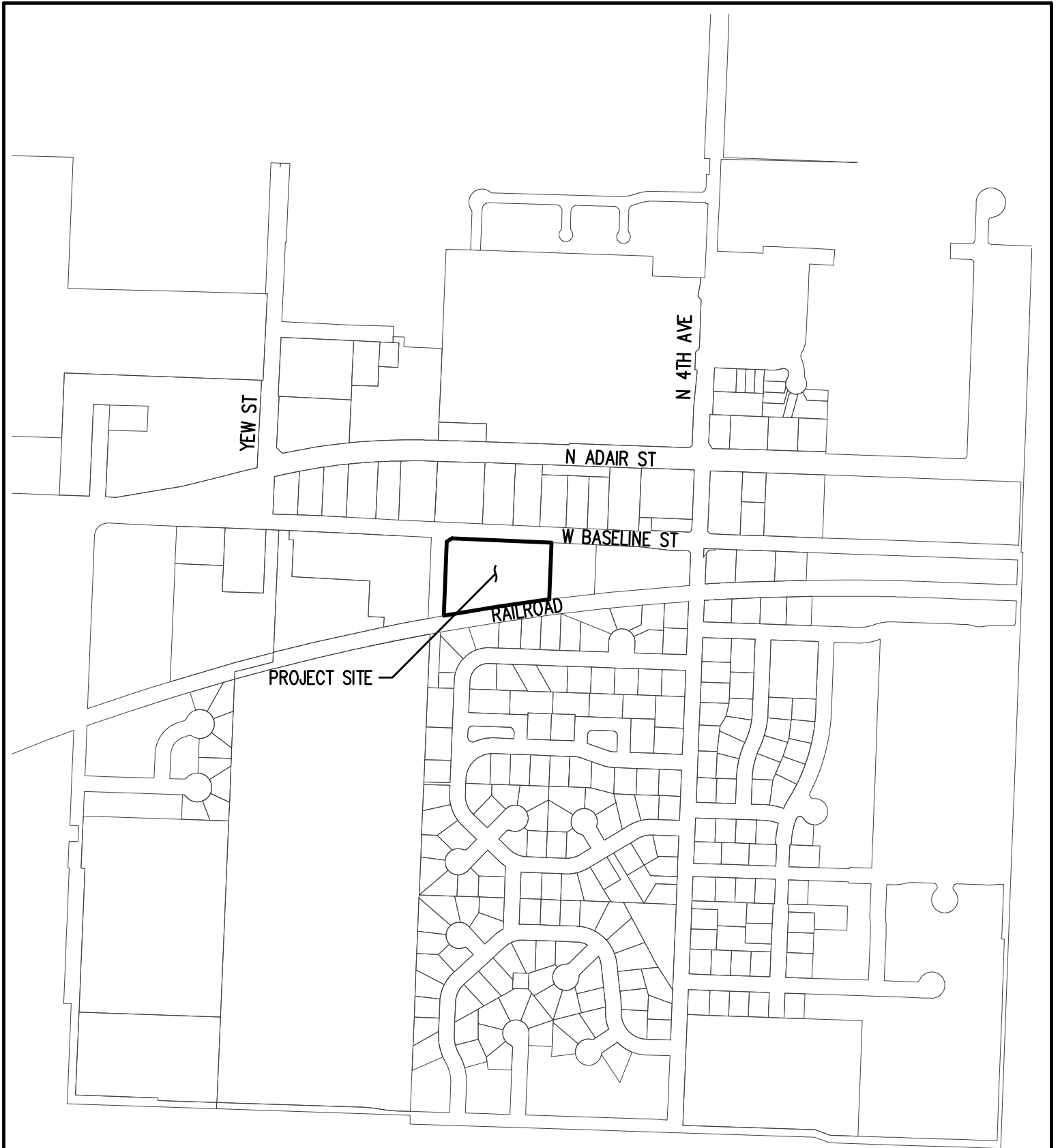

DATE: 07/10/2023

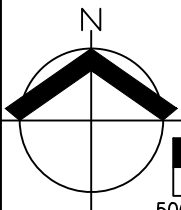

SCALE: 1" = 500 FEET

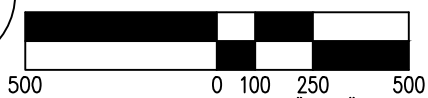

ORIGINAL PAGE SIZE: 8.5" x 11"

CORNELIUS SOUTH COMMERCIAL: VICINITY MAP

AKS ENGINEERING & FORESTRY, LLC
 12965 SW HERMAN RD, STE 100
 TUALATIN, OR 97062
 503.563.6151 WWW.AKS-ENG.COM



FIGURE
1

DRWN: JG

CHKD: CMS

AKS JOB:

9656

Figure 2: Pre-Developed Basin Delineation

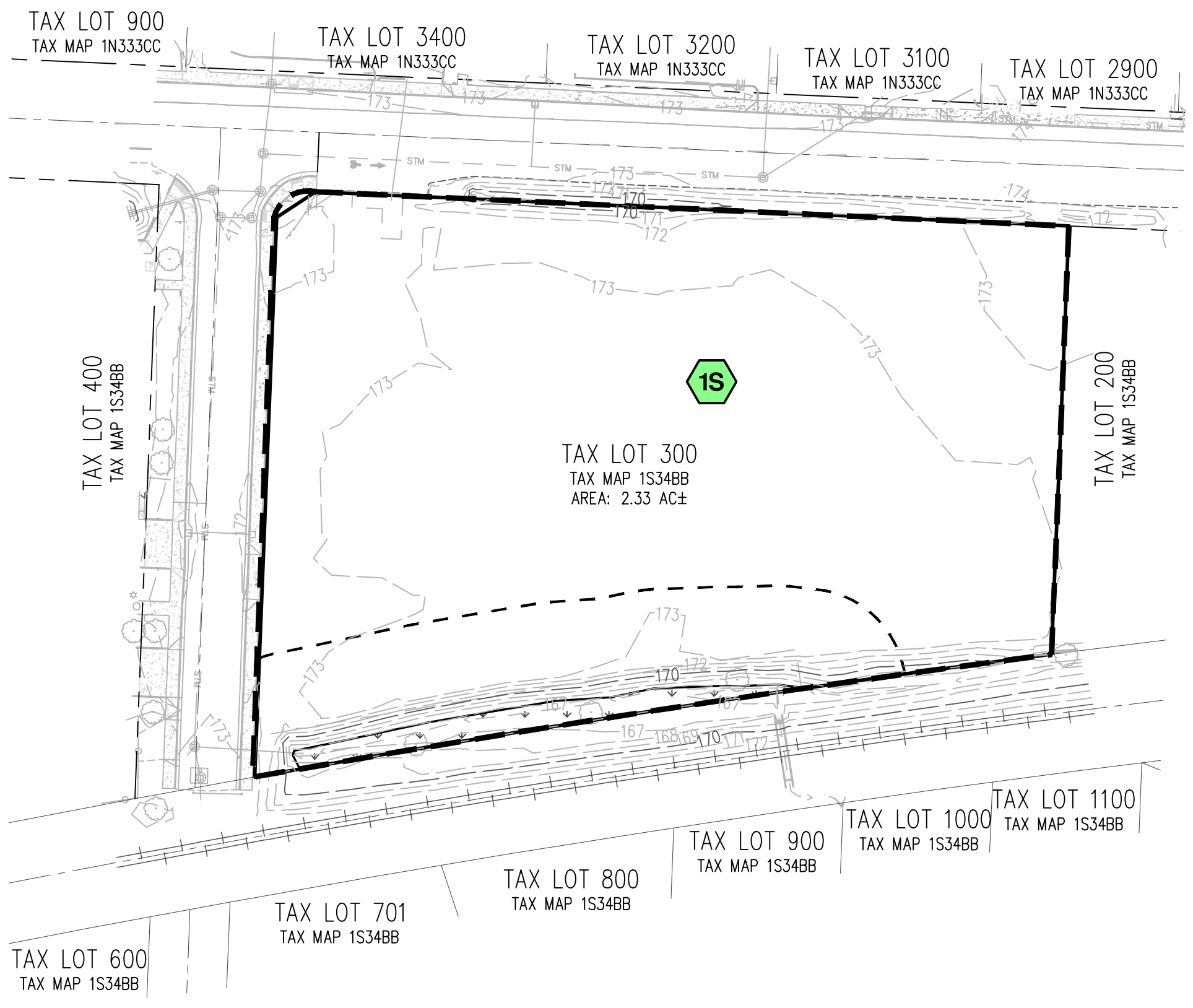

LEGEND

EXISTING GROUND CONTOUR (1 FT) ---

EXISTING GROUND CONTOUR (5 FT) -173-

SUBCATCHMENT 

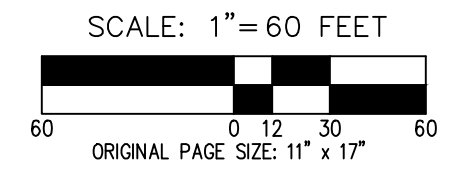
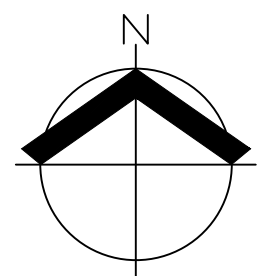

DATE: 07/28/2023

PRE-DEVELOPED BASIN DELINEATION	FIGURE
CORNELIUS SOUTH COMMERCIAL	2
AKS ENGINEERING & FORESTRY, LLC 12965 SW HERMAN RD, STE 100 TUALATIN, OR 97062 503.563.6151 WWW.AKS-ENG.COM	DRWN: JG CHKD: CMS AKS JOB: 9656



DWG: 9656 PRE-DEVELOPED | PRE

Figure 3: Post-Developed Basin Delineation

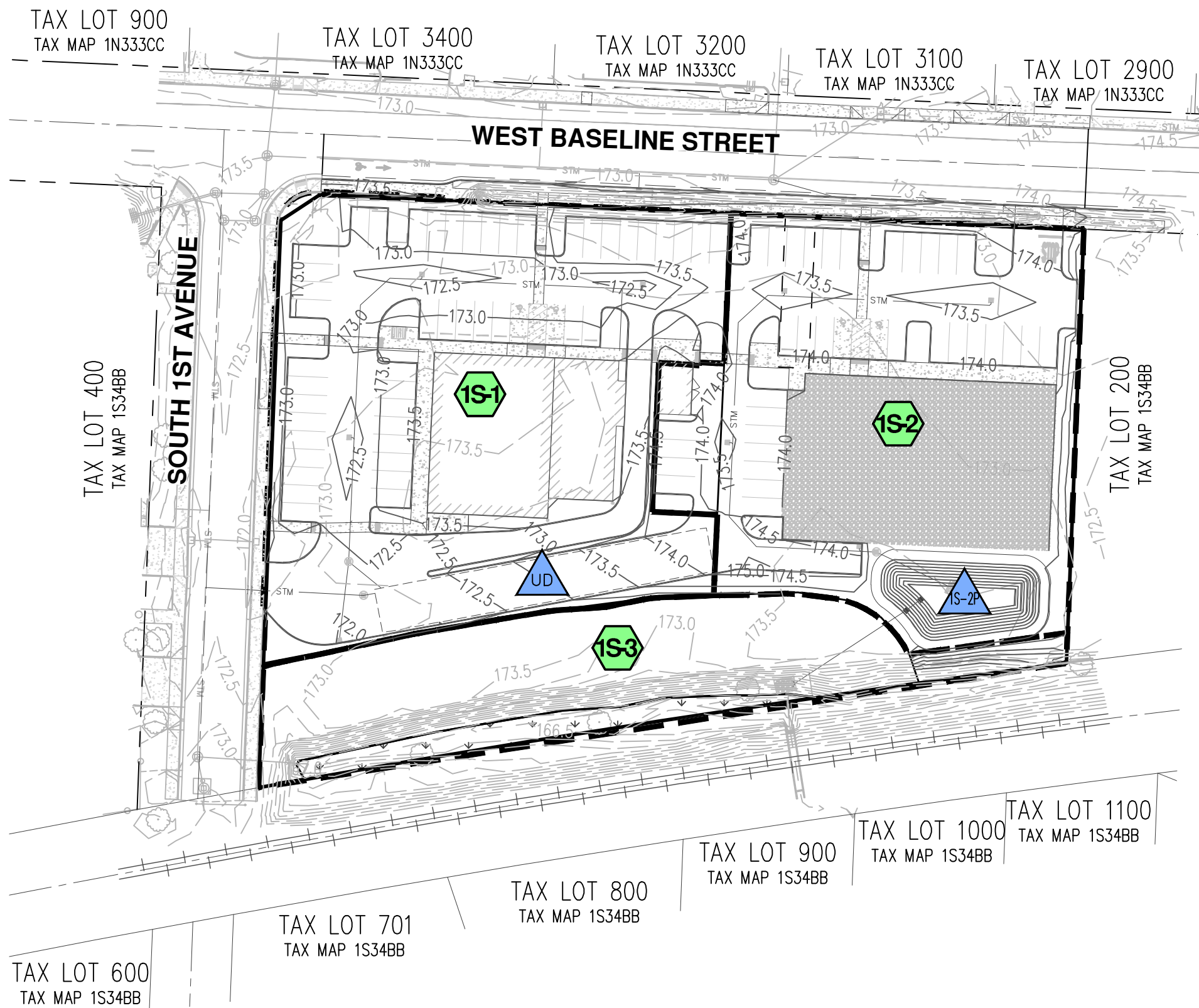

LEGEND

EXISTING GROUND CONTOUR (0.5 FT)	---
EXISTING GROUND CONTOUR (2.5 FT)	—173.0—
FINISHED GRADE CONTOUR (0.5 FT)	---
FINISHED GRADE CONTOUR (2.5 FT)	—173.0—
SUBCATCHMENT	1S-1
STORMWATER FACILITY	1S-2P

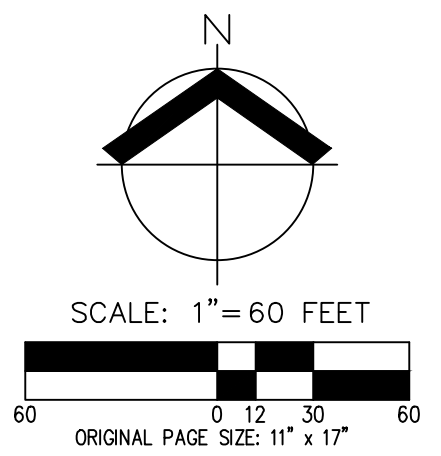

DATE: 07/28/2023

POST-DEVELOPED BASIN DELINEATION	FIGURE
CORNELIUS SOUTH COMMERCIAL	3
AKS ENGINEERING & FORESTRY, LLC 12965 SW HERMAN RD, STE 100 TUALATIN, OR 97062 503.563.6151 WWW.AKS-ENG.COM	DRWN: JG CHKD: CMS AKS JOB: 9656



DWG: 9656 POST-DEVELOPED | POST

Figure 4: Stormwater Treatment Map

WEST BASELINE STREET UNTREATED
 NEW IMPERVIOUS: ±2,675 SF
 MODIFIED IMPERVIOUS: ±6,782 SF

TAX LOT 900 TAX MAP 1N333CC
 TAX LOT 3400 TAX MAP 1N333CC
 TAX LOT 3200 TAX MAP 1N333CC
 TAX LOT 3100 TAX MAP 1N333CC
 TAX LOT 2900 TAX MAP 1N333CC

WEST BASELINE STREET

SOUTH 1ST AVENUE UNTREATED
 NEW IMPERVIOUS: ±0 SF
 MODIFIED IMPERVIOUS: ±420 SF

TAX LOT 400
 TAX MAP 1S34BB

SOUTH 1ST AVENUE

TAX LOT 200
 TAX MAP 1S34BB

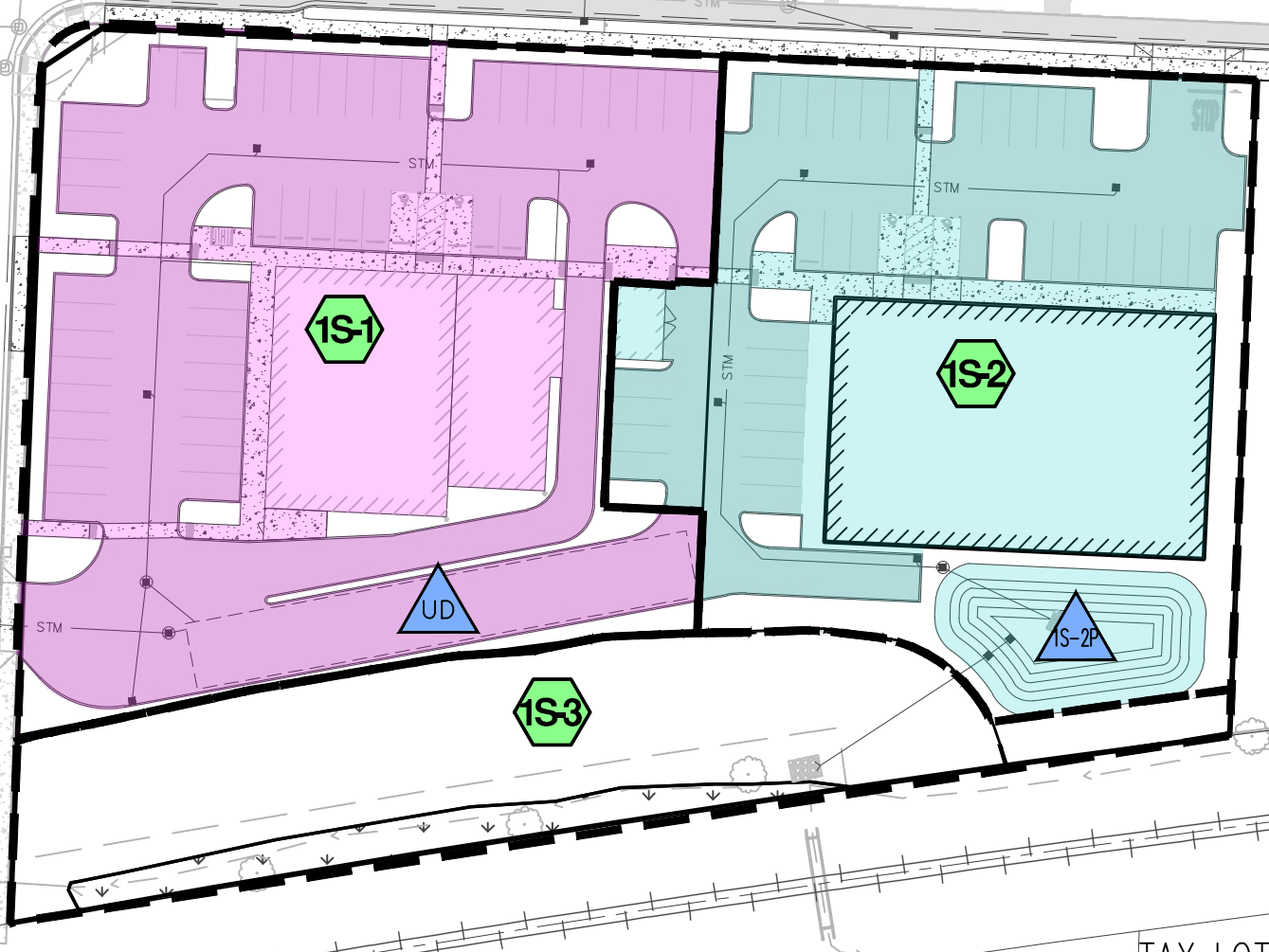

ONSITE

EXTENDED DRY BASIN (1S-2P)

INDICATES NEW IMPERVIOUS AREA RECEIVING TREATMENT WITHIN EXTENDED DRY BASIN (1S-2P) - ±31,594 SF

TOTAL TREATMENT AREA (SF) = ±31,594

UNDERGROUND DETENTION (UD)

INDICATES NEW IMPERVIOUS AREA RECEIVING TREATMENT WITHIN UNDERGROUND DETENTION (UD) - ±37,396 SF

TOTAL TREATMENT AREA (SF) = ±37,196

TOTAL ONSITE IMPERVIOUS AREA SUMMARY	
TOTAL IMPERVIOUS AREA	- ±68,990 SF
TOTAL IMPERVIOUS AREA TREATED	- ±68,990 SF

LEGEND

SUBCATCHMENT 

STORMWATER FACILITY 

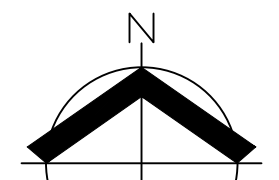

SCALE: 1" = 60 FEET



ORIGINAL PAGE SIZE: 11" x 17"

DATE: 07/28/2023

STORMWATER TREATMENT MAP		FIGURE
CORNELIUS SOUTH COMMERCIAL		4
AKS ENGINEERING & FORESTRY, LLC 12965 SW HERMAN RD, STE 100 TUALATIN, OR 97062 503.563.6151 WWW.AKS-ENG.COM		DRWN: JG CHKD: CMS AKS JOB: 9656



DMG: 9656 POST-DEVELOPED TREATMENT | POST TREATMENT

Appendix A: HydroCAD Reports for Pre-Developed Conditions Storm Events

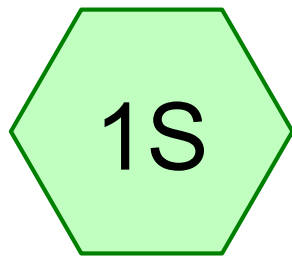

Site

Total

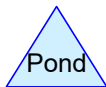
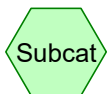

9656 Prelim Pre-Developed

Prepared by AKS Engineering & Forestry, LLC

Printed 7/10/2023

HydroCAD® 10.00-22 s/n 01338 © 2018 HydroCAD Software Solutions LLC

Area Listing (all nodes)

Area (sq-ft)	CN	Description (subcatchment-numbers)
10,627	65	Brush, Good, HSG C (1S)
9,750	73	Brush, Good, HSG D (1S)
42,964	85	Row crops, straight row, Good, HSG C (1S)
39,421	89	Row crops, straight row, Good, HSG D (1S)
102,762	83	TOTAL AREA

9656 Prelim Pre-Developed

Type IA 24-hr 2-YR Rainfall=2.50"

Prepared by AKS Engineering & Forestry, LLC

Printed 7/10/2023

HydroCAD® 10.00-22 s/n 01338 © 2018 HydroCAD Software Solutions LLC

Time span=0.00-24.00 hrs, dt=0.05 hrs, 481 points

Runoff by SBUH method, Split Pervious/Imperv.

Reach routing by Dyn-Stor-Ind method - Pond routing by Dyn-Stor-Ind method

Subcatchment 1S: Site

Runoff Area=102,762 sf 0.00% Impervious Runoff Depth>1.05"

Flow Length=200' Slope=0.0400 '/' Tc=14.6 min CN=83/0 Runoff=0.46 cfs 8,966 cf

Link Pre: Total

Inflow=0.46 cfs 8,966 cf

Primary=0.46 cfs 8,966 cf

Total Runoff Area = 102,762 sf Runoff Volume = 8,966 cf Average Runoff Depth = 1.05"
100.00% Pervious = 102,762 sf 0.00% Impervious = 0 sf

9656 Prelim Pre-Developed

Prepared by AKS Engineering & Forestry, LLC

HydroCAD® 10.00-22 s/n 01338 © 2018 HydroCAD Software Solutions LLC

Type IA 24-hr 2-YR Rainfall=2.50"

Printed 7/10/2023

Summary for Subcatchment 1S: Site

Runoff = 0.46 cfs @ 8.03 hrs, Volume= 8,966 cf, Depth> 1.05"

Runoff by SBUH method, Split Pervious/Imperv., Time Span= 0.00-24.00 hrs, dt= 0.05 hrs
Type IA 24-hr 2-YR Rainfall=2.50"

Area (sf)	CN	Description
42,964	85	Row crops, straight row, Good, HSG C
39,421	89	Row crops, straight row, Good, HSG D
9,750	73	Brush, Good, HSG D
10,627	65	Brush, Good, HSG C
102,762	83	Weighted Average
102,762	83	100.00% Pervious Area

Tc (min)	Length (feet)	Slope (ft/ft)	Velocity (ft/sec)	Capacity (cfs)	Description
14.6	200	0.0400	0.23		Sheet Flow, Pre-Developed Grass: Short n= 0.150 P2= 2.50"

Subcatchment 1S: Site

Hydrograph

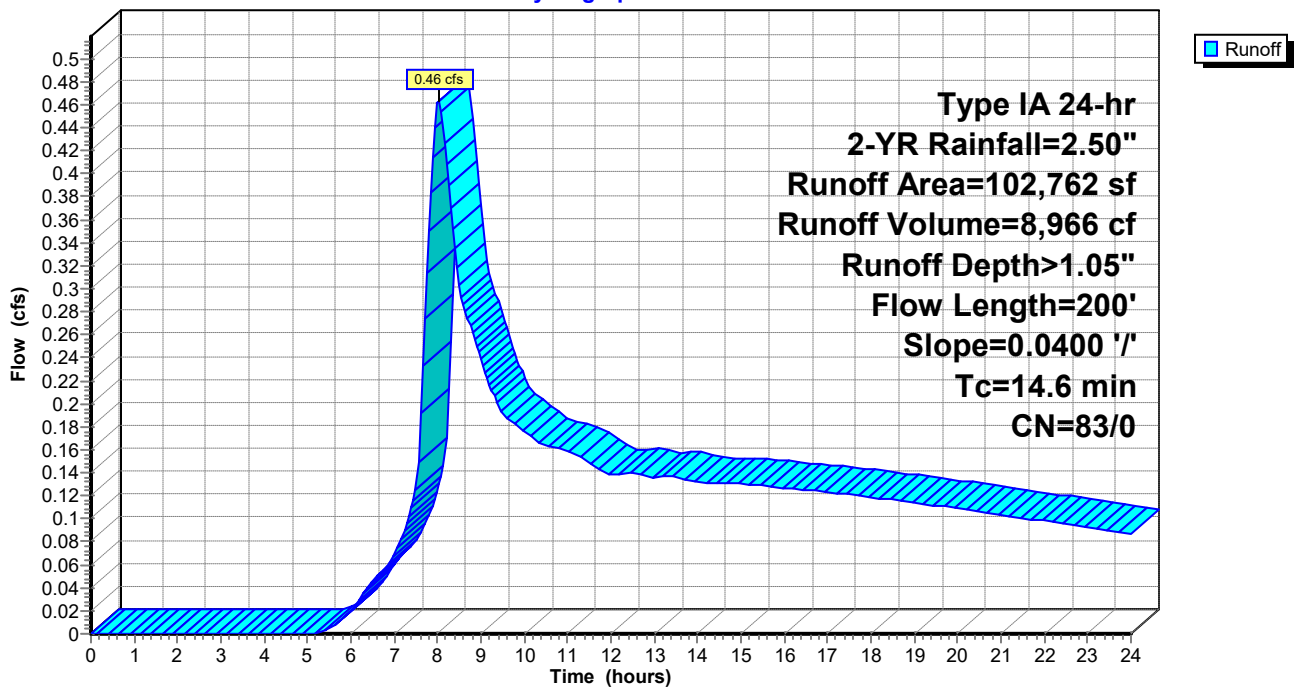

9656 Prelim Pre-Developed

Prepared by AKS Engineering & Forestry, LLC

HydroCAD® 10.00-22 s/n 01338 © 2018 HydroCAD Software Solutions LLC

Type IA 24-hr 2-YR Rainfall=2.50"

Printed 7/10/2023

Summary for Link Pre: Total

Inflow Area = 102,762 sf, 0.00% Impervious, Inflow Depth > 1.05" for 2-YR event
Inflow = 0.46 cfs @ 8.03 hrs, Volume= 8,966 cf
Primary = 0.46 cfs @ 8.03 hrs, Volume= 8,966 cf, Atten= 0%, Lag= 0.0 min

Primary outflow = Inflow, Time Span= 0.00-24.00 hrs, dt= 0.05 hrs

Link Pre: Total

Hydrograph

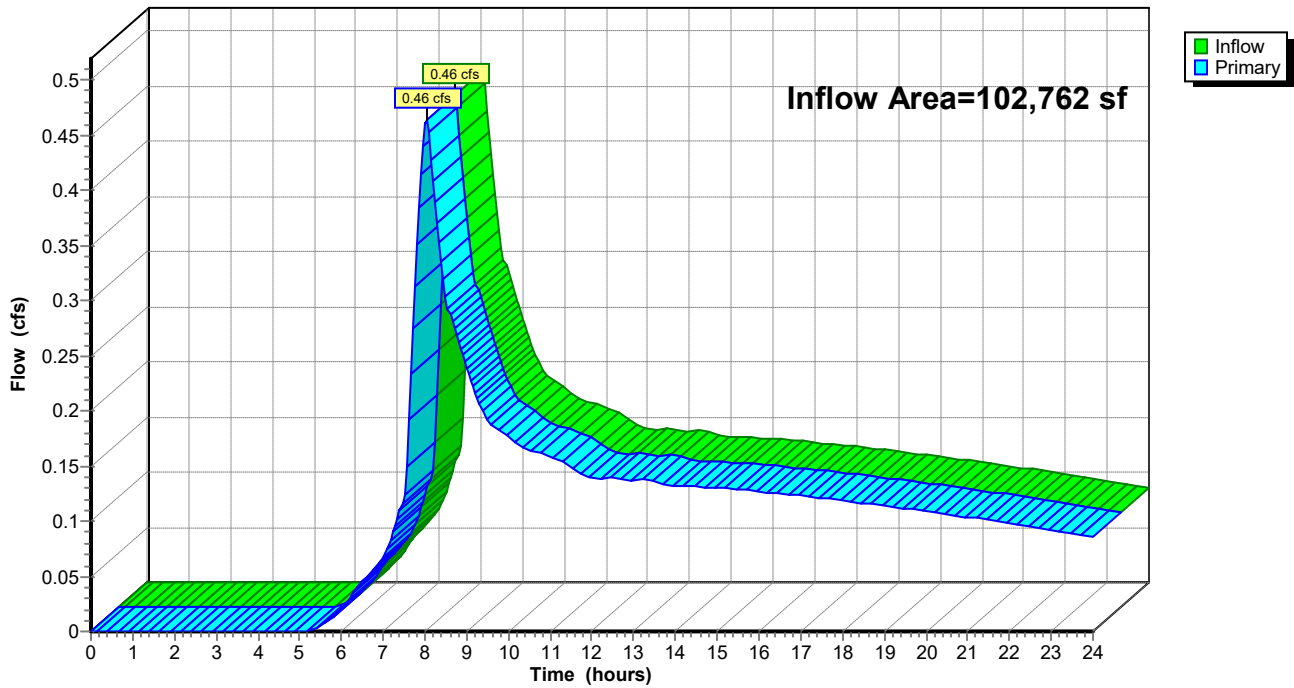

9656 Prelim Pre-Developed

Type IA 24-hr 5-YR Rainfall=3.10"

Prepared by AKS Engineering & Forestry, LLC

Printed 7/10/2023

HydroCAD® 10.00-22 s/n 01338 © 2018 HydroCAD Software Solutions LLC

Time span=0.00-24.00 hrs, dt=0.05 hrs, 481 points

Runoff by SBUH method, Split Pervious/Imperv.

Reach routing by Dyn-Stor-Ind method - Pond routing by Dyn-Stor-Ind method

Subcatchment 1S: Site

Runoff Area=102,762 sf 0.00% Impervious Runoff Depth>1.52"

Flow Length=200' Slope=0.0400 '/' Tc=14.6 min CN=83/0 Runoff=0.73 cfs 12,980 cf

Link Pre: Total

Inflow=0.73 cfs 12,980 cf

Primary=0.73 cfs 12,980 cf

Total Runoff Area = 102,762 sf Runoff Volume = 12,980 cf Average Runoff Depth = 1.52"
100.00% Pervious = 102,762 sf 0.00% Impervious = 0 sf

9656 Prelim Pre-Developed

Prepared by AKS Engineering & Forestry, LLC

HydroCAD® 10.00-22 s/n 01338 © 2018 HydroCAD Software Solutions LLC

Type IA 24-hr 5-YR Rainfall=3.10"

Printed 7/10/2023

Summary for Subcatchment 1S: Site

Runoff = 0.73 cfs @ 8.02 hrs, Volume= 12,980 cf, Depth> 1.52"

Runoff by SBUH method, Split Pervious/Imperv., Time Span= 0.00-24.00 hrs, dt= 0.05 hrs
Type IA 24-hr 5-YR Rainfall=3.10"

Area (sf)	CN	Description
42,964	85	Row crops, straight row, Good, HSG C
39,421	89	Row crops, straight row, Good, HSG D
9,750	73	Brush, Good, HSG D
10,627	65	Brush, Good, HSG C
102,762	83	Weighted Average
102,762	83	100.00% Pervious Area

Tc (min)	Length (feet)	Slope (ft/ft)	Velocity (ft/sec)	Capacity (cfs)	Description
14.6	200	0.0400	0.23		Sheet Flow, Pre-Developed Grass: Short n= 0.150 P2= 2.50"

Subcatchment 1S: Site

Hydrograph

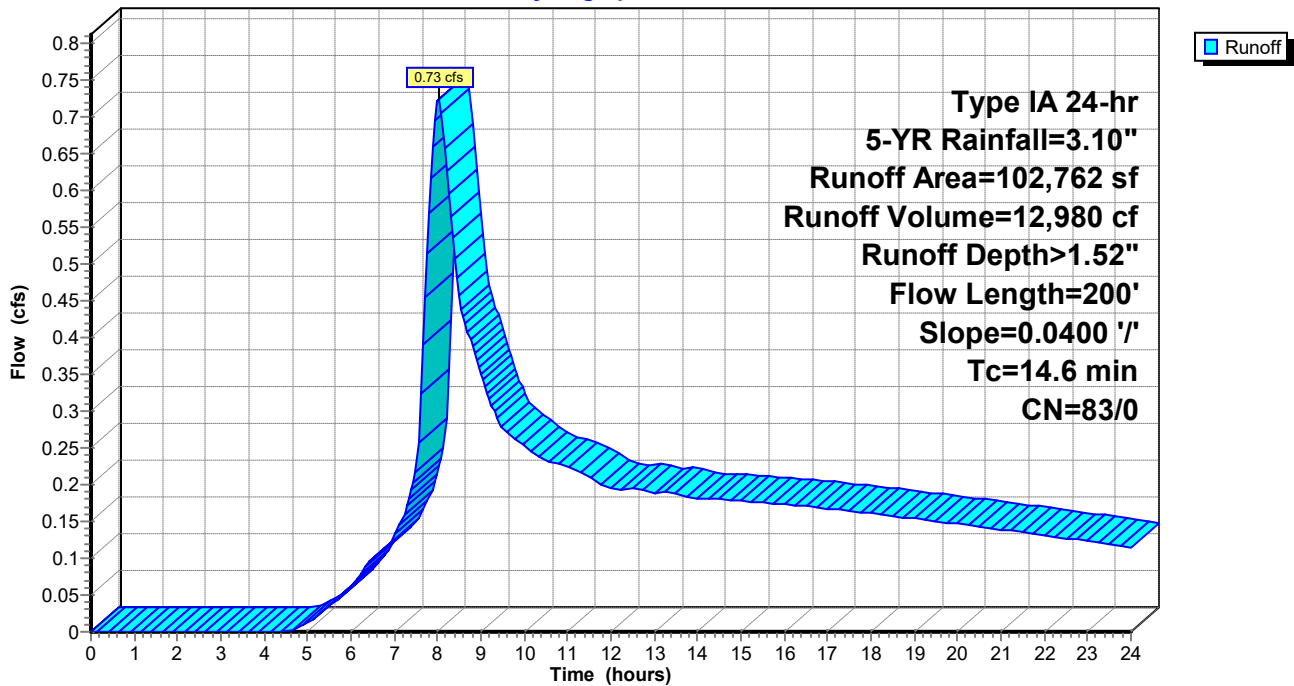

9656 Prelim Pre-Developed

Prepared by AKS Engineering & Forestry, LLC

HydroCAD® 10.00-22 s/n 01338 © 2018 HydroCAD Software Solutions LLC

Type IA 24-hr 5-YR Rainfall=3.10"

Printed 7/10/2023

Summary for Link Pre: Total

Inflow Area = 102,762 sf, 0.00% Impervious, Inflow Depth > 1.52" for 5-YR event
Inflow = 0.73 cfs @ 8.02 hrs, Volume= 12,980 cf
Primary = 0.73 cfs @ 8.02 hrs, Volume= 12,980 cf, Atten= 0%, Lag= 0.0 min

Primary outflow = Inflow, Time Span= 0.00-24.00 hrs, dt= 0.05 hrs

Link Pre: Total

Hydrograph

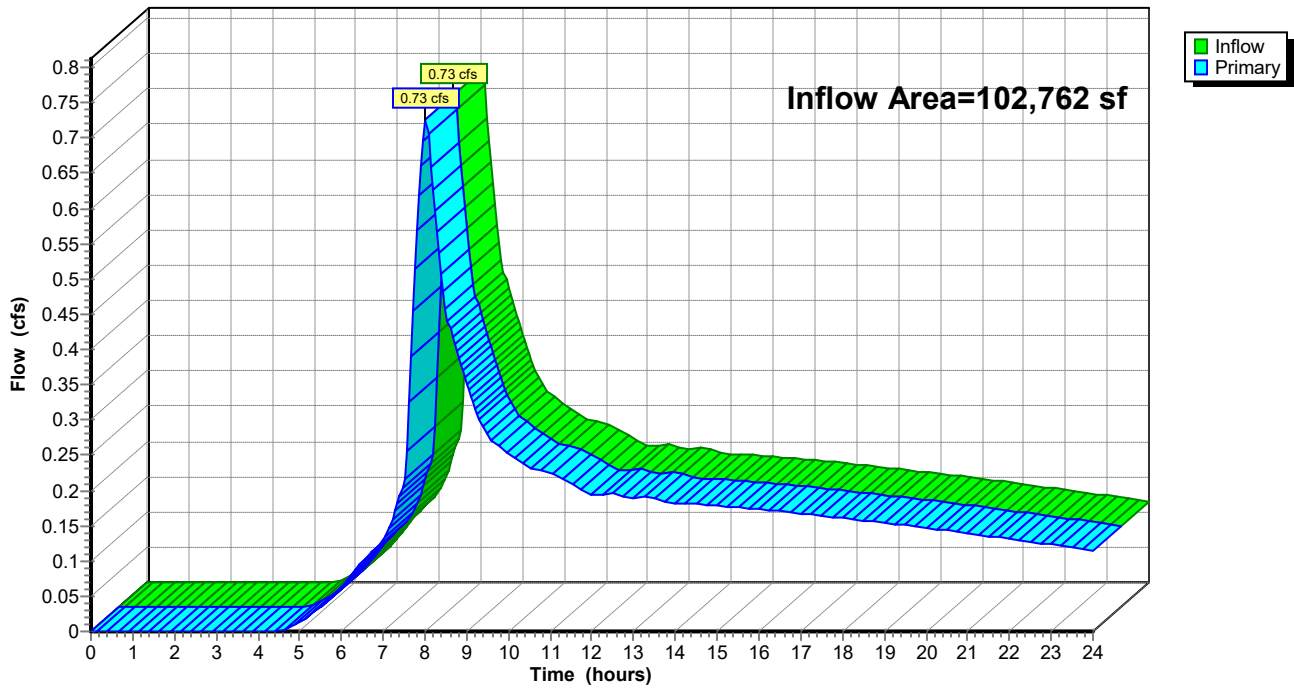

9656 Prelim Pre-Developed

Type IA 24-hr 10-YR Rainfall=3.45"

Prepared by AKS Engineering & Forestry, LLC

Printed 7/10/2023

HydroCAD® 10.00-22 s/n 01338 © 2018 HydroCAD Software Solutions LLC

Time span=0.00-24.00 hrs, dt=0.05 hrs, 481 points

Runoff by SBUH method, Split Pervious/Imperv.

Reach routing by Dyn-Stor-Ind method - Pond routing by Dyn-Stor-Ind method

Subcatchment 1S: Site

Runoff Area=102,762 sf 0.00% Impervious Runoff Depth>1.80"

Flow Length=200' Slope=0.0400 '/' Tc=14.6 min CN=83/0 Runoff=0.89 cfs 15,441 cf

Link Pre: Total

Inflow=0.89 cfs 15,441 cf

Primary=0.89 cfs 15,441 cf

Total Runoff Area = 102,762 sf Runoff Volume = 15,441 cf Average Runoff Depth = 1.80"
100.00% Pervious = 102,762 sf 0.00% Impervious = 0 sf

9656 Prelim Pre-Developed

Prepared by AKS Engineering & Forestry, LLC

HydroCAD® 10.00-22 s/n 01338 © 2018 HydroCAD Software Solutions LLC

Type IA 24-hr 10-YR Rainfall=3.45"

Printed 7/10/2023

Summary for Subcatchment 1S: Site

Runoff = 0.89 cfs @ 8.02 hrs, Volume= 15,441 cf, Depth> 1.80"

Runoff by SBUH method, Split Pervious/Imperv., Time Span= 0.00-24.00 hrs, dt= 0.05 hrs
Type IA 24-hr 10-YR Rainfall=3.45"

Area (sf)	CN	Description
42,964	85	Row crops, straight row, Good, HSG C
39,421	89	Row crops, straight row, Good, HSG D
9,750	73	Brush, Good, HSG D
10,627	65	Brush, Good, HSG C
102,762	83	Weighted Average
102,762	83	100.00% Pervious Area

Tc (min)	Length (feet)	Slope (ft/ft)	Velocity (ft/sec)	Capacity (cfs)	Description
14.6	200	0.0400	0.23		Sheet Flow, Pre-Developed Grass: Short n= 0.150 P2= 2.50"

Subcatchment 1S: Site

Hydrograph

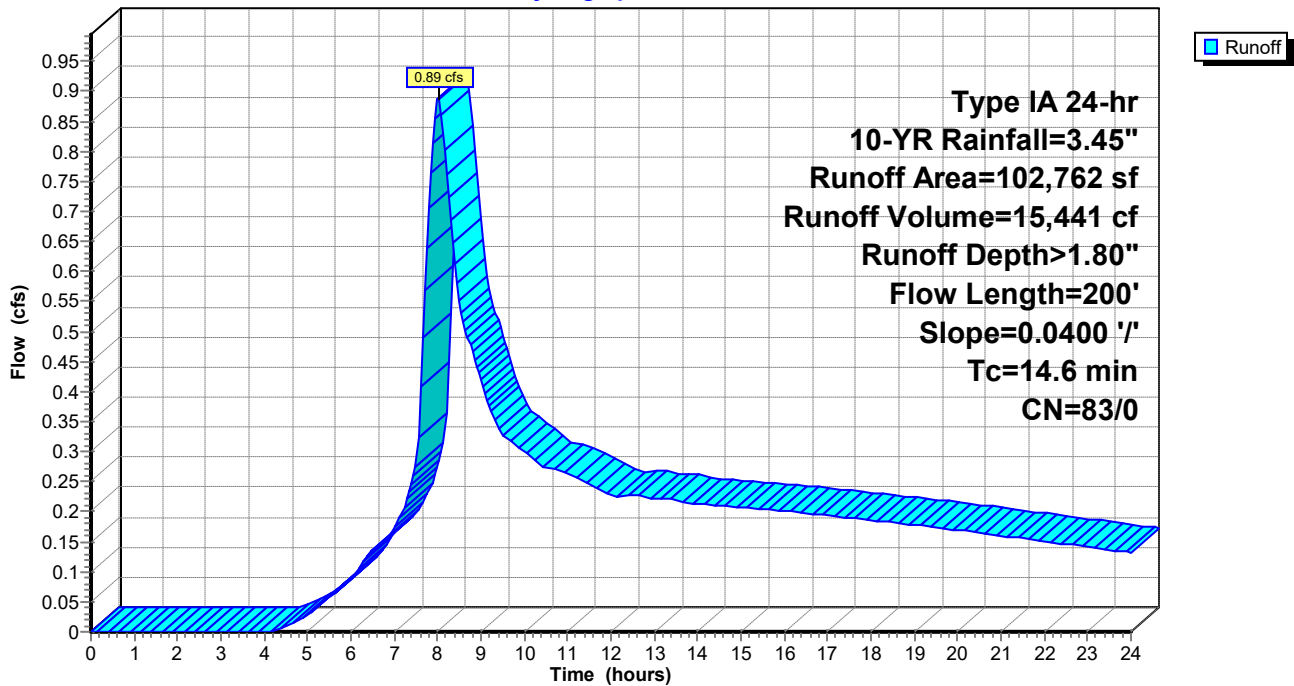

Summary for Link Pre: Total

Inflow Area = 102,762 sf, 0.00% Impervious, Inflow Depth > 1.80" for 10-YR event
Inflow = 0.89 cfs @ 8.02 hrs, Volume= 15,441 cf
Primary = 0.89 cfs @ 8.02 hrs, Volume= 15,441 cf, Atten= 0%, Lag= 0.0 min

Primary outflow = Inflow, Time Span= 0.00-24.00 hrs, dt= 0.05 hrs

Link Pre: Total

Hydrograph

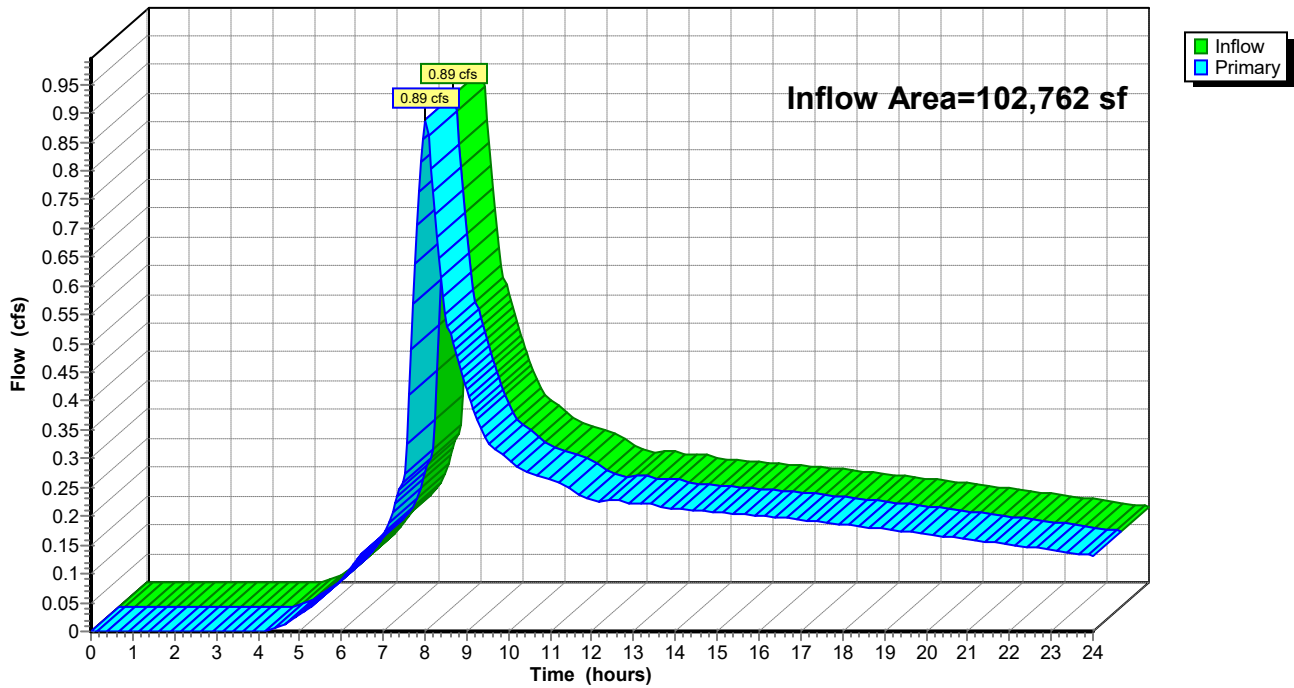

9656 Prelim Pre-Developed

Type IA 24-hr 25-YR Rainfall=3.90"

Prepared by AKS Engineering & Forestry, LLC

Printed 7/10/2023

HydroCAD® 10.00-22 s/n 01338 © 2018 HydroCAD Software Solutions LLC

Time span=0.00-24.00 hrs, dt=0.05 hrs, 481 points

Runoff by SBUH method, Split Pervious/Imperv.

Reach routing by Dyn-Stor-Ind method - Pond routing by Dyn-Stor-Ind method

Subcatchment 1S: Site

Runoff Area=102,762 sf 0.00% Impervious Runoff Depth>2.18"

Flow Length=200' Slope=0.0400 '/' Tc=14.6 min CN=83/0 Runoff=1.10 cfs 18,702 cf

Link Pre: Total

Inflow=1.10 cfs 18,702 cf

Primary=1.10 cfs 18,702 cf

Total Runoff Area = 102,762 sf Runoff Volume = 18,702 cf Average Runoff Depth = 2.18"
100.00% Pervious = 102,762 sf 0.00% Impervious = 0 sf

9656 Prelim Pre-Developed

Prepared by AKS Engineering & Forestry, LLC

HydroCAD® 10.00-22 s/n 01338 © 2018 HydroCAD Software Solutions LLC

Type IA 24-hr 25-YR Rainfall=3.90"

Printed 7/10/2023

Summary for Subcatchment 1S: Site

Runoff = 1.10 cfs @ 8.01 hrs, Volume= 18,702 cf, Depth> 2.18"

Runoff by SBUH method, Split Pervious/Imperv., Time Span= 0.00-24.00 hrs, dt= 0.05 hrs
Type IA 24-hr 25-YR Rainfall=3.90"

Area (sf)	CN	Description
42,964	85	Row crops, straight row, Good, HSG C
39,421	89	Row crops, straight row, Good, HSG D
9,750	73	Brush, Good, HSG D
10,627	65	Brush, Good, HSG C
102,762	83	Weighted Average
102,762	83	100.00% Pervious Area

Tc (min)	Length (feet)	Slope (ft/ft)	Velocity (ft/sec)	Capacity (cfs)	Description
14.6	200	0.0400	0.23		Sheet Flow, Pre-Developed Grass: Short n= 0.150 P2= 2.50"

Subcatchment 1S: Site

Hydrograph

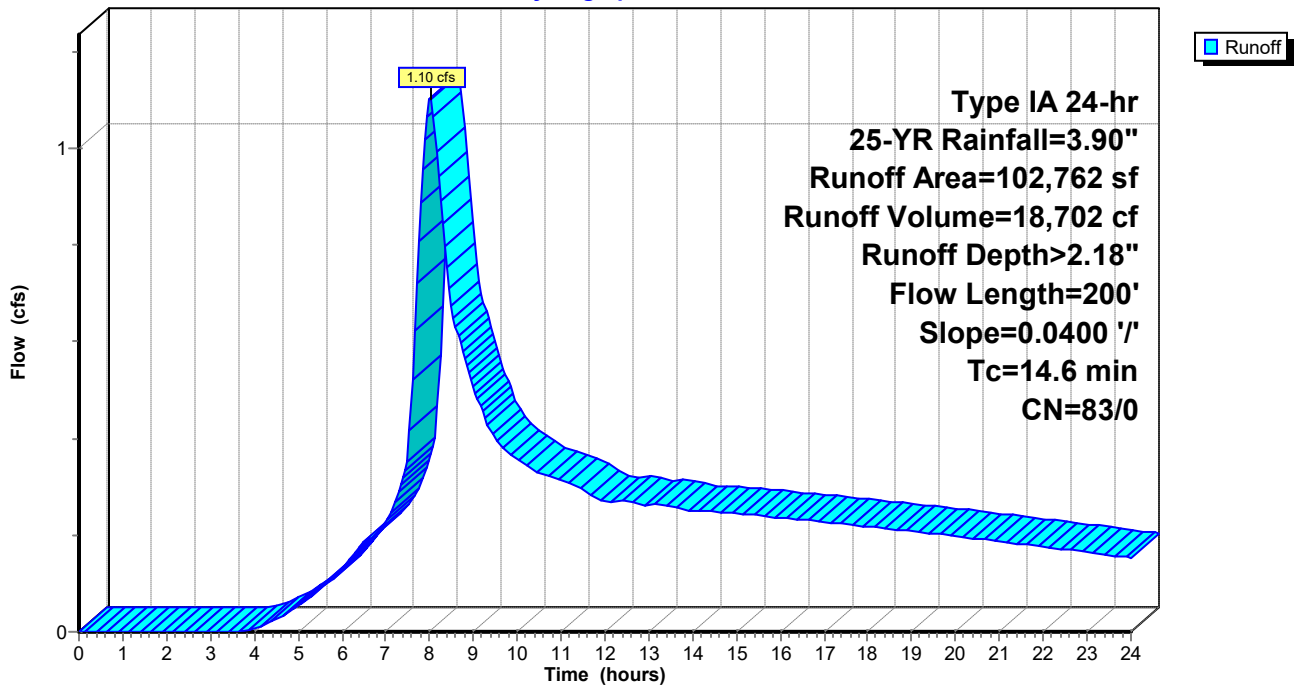

Summary for Link Pre: Total

Inflow Area = 102,762 sf, 0.00% Impervious, Inflow Depth > 2.18" for 25-YR event
Inflow = 1.10 cfs @ 8.01 hrs, Volume= 18,702 cf
Primary = 1.10 cfs @ 8.01 hrs, Volume= 18,702 cf, Atten= 0%, Lag= 0.0 min

Primary outflow = Inflow, Time Span= 0.00-24.00 hrs, dt= 0.05 hrs

Link Pre: Total

Hydrograph

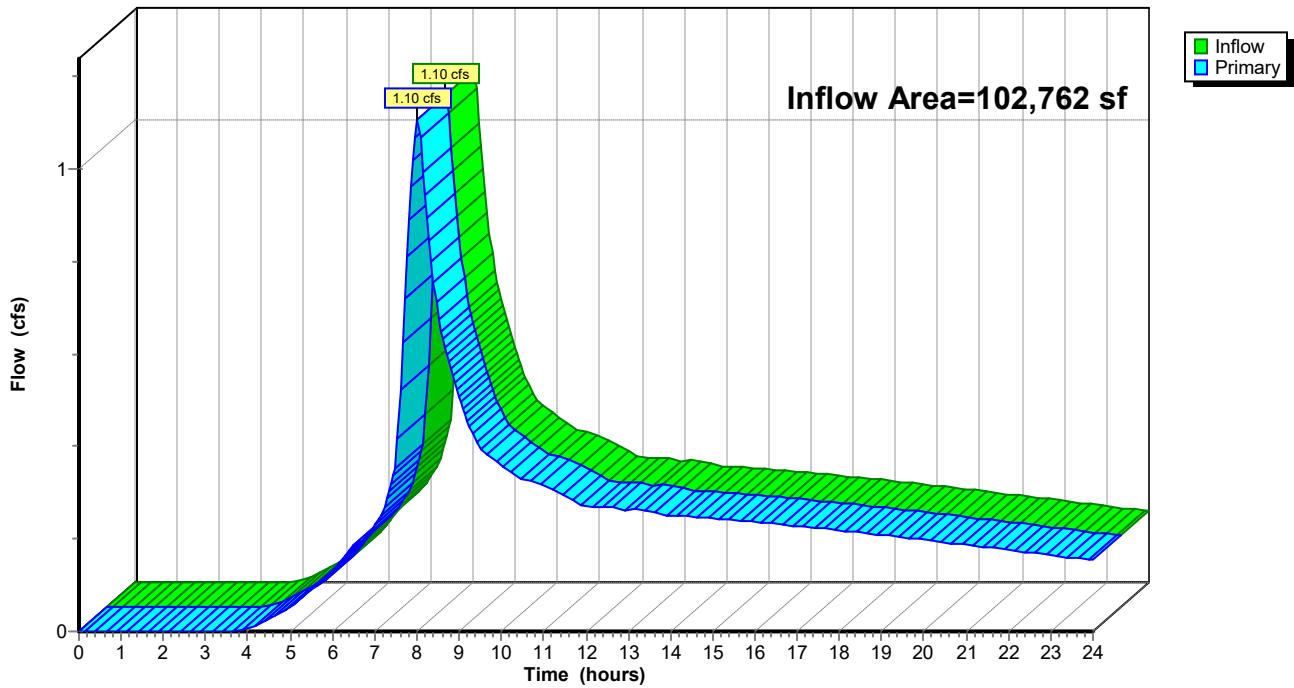

Appendix B: HydroCAD Reports for Post-Developed Conditions Storm Events

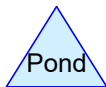
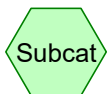
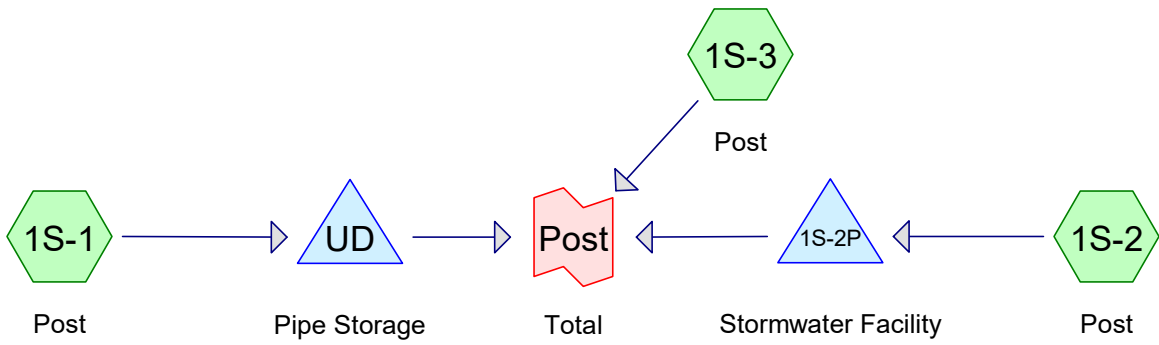

Routing Diagram for 9656 Prelim Post-Developed
 Prepared by AKS Engineering & Forestry, LLC, Printed 7/28/2023
 HydroCAD® 10.00-22 s/n 01338 © 2018 HydroCAD Software Solutions LLC

9656 Prelim Post-Developed

Prepared by AKS Engineering & Forestry, LLC

Printed 7/28/2023

HydroCAD® 10.00-22 s/n 01338 © 2018 HydroCAD Software Solutions LLC

Area Listing (all nodes)

Area (sq-ft)	CN	Description (subcatchment-numbers)
13,395	80	>75% Grass cover, Good, HSG D (1S-1, 1S-2)
10,627	65	Brush, Good, HSG C (1S-3)
9,750	73	Brush, Good, HSG D (1S-3)
68,990	98	Paved parking, HSG D (1S-1, 1S-2)
102,762	90	TOTAL AREA

9656 Prelim Post-Developed

Type IA 24-hr 2-YR Rainfall=2.50"

Prepared by AKS Engineering & Forestry, LLC

Printed 7/28/2023

HydroCAD® 10.00-22 s/n 01338 © 2018 HydroCAD Software Solutions LLC

Time span=0.00-24.00 hrs, dt=0.05 hrs, 481 points

Runoff by SBUH method, Split Pervious/Imperv.

Reach routing by Dyn-Stor-Ind method - Pond routing by Dyn-Stor-Ind method

Subcatchment 1S-1: Post	Runoff Area=44,783 sf 83.50% Impervious Runoff Depth>2.04" Tc=5.0 min CN=80/98 Runoff=0.52 cfs 7,610 cf
Subcatchment 1S-2: Post	Runoff Area=37,602 sf 84.02% Impervious Runoff Depth>2.05" Tc=5.0 min CN=80/98 Runoff=0.44 cfs 6,412 cf
Subcatchment 1S-3: Post	Runoff Area=20,377 sf 0.00% Impervious Runoff Depth>0.42" Tc=10.0 min CN=69/0 Runoff=0.01 cfs 708 cf
Pond 1S-2P: Stormwater Facility	Peak Elev=171.90' Storage=2,554 cf Inflow=0.44 cfs 6,412 cf Outflow=0.10 cfs 4,260 cf
Pond UD: Pipe Storage	Peak Elev=171.29' Storage=3,461 cf Inflow=0.52 cfs 7,610 cf Outflow=0.12 cfs 4,237 cf
Link Post: Total	Inflow=0.23 cfs 9,205 cf Primary=0.23 cfs 9,205 cf

Total Runoff Area = 102,762 sf Runoff Volume = 14,730 cf Average Runoff Depth = 1.72"
32.86% Pervious = 33,772 sf 67.14% Impervious = 68,990 sf

9656 Prelim Post-Developed

Prepared by AKS Engineering & Forestry, LLC

HydroCAD® 10.00-22 s/n 01338 © 2018 HydroCAD Software Solutions LLC

Type IA 24-hr 2-YR Rainfall=2.50"

Printed 7/28/2023

Summary for Subcatchment 1S-1: Post

Runoff = 0.52 cfs @ 7.91 hrs, Volume= 7,610 cf, Depth> 2.04"

Runoff by SBUH method, Split Pervious/Imperv., Time Span= 0.00-24.00 hrs, dt= 0.05 hrs
Type IA 24-hr 2-YR Rainfall=2.50"

Area (sf)	CN	Description
37,396	98	Paved parking, HSG D
7,387	80	>75% Grass cover, Good, HSG D
44,783	95	Weighted Average
7,387	80	16.50% Pervious Area
37,396	98	83.50% Impervious Area

Tc (min)	Length (feet)	Slope (ft/ft)	Velocity (ft/sec)	Capacity (cfs)	Description
5.0					Direct Entry,

Subcatchment 1S-1: Post

Hydrograph

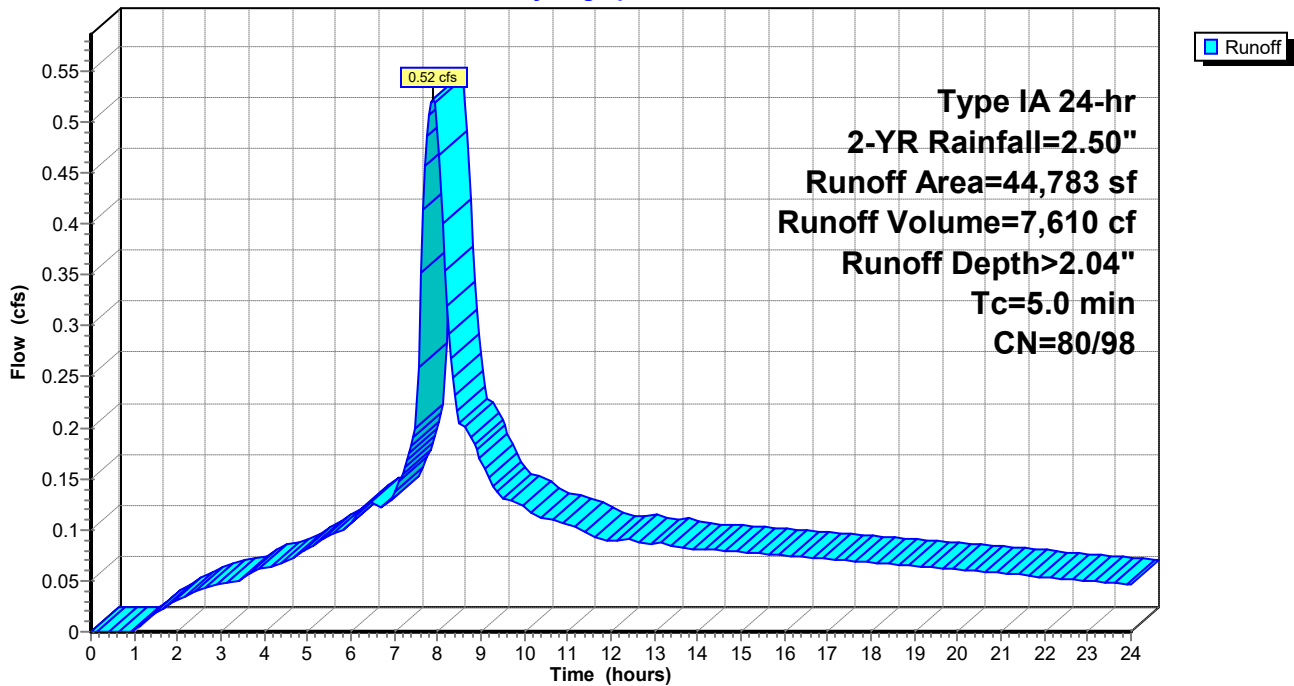

9656 Prelim Post-Developed

Prepared by AKS Engineering & Forestry, LLC

HydroCAD® 10.00-22 s/n 01338 © 2018 HydroCAD Software Solutions LLC

Type IA 24-hr 2-YR Rainfall=2.50"

Printed 7/28/2023

Summary for Subcatchment 1S-2: Post

Runoff = 0.44 cfs @ 7.91 hrs, Volume= 6,412 cf, Depth> 2.05"

Runoff by SBUH method, Split Pervious/Imperv., Time Span= 0.00-24.00 hrs, dt= 0.05 hrs
Type IA 24-hr 2-YR Rainfall=2.50"

Area (sf)	CN	Description
31,594	98	Paved parking, HSG D
6,008	80	>75% Grass cover, Good, HSG D
37,602	95	Weighted Average
6,008	80	15.98% Pervious Area
31,594	98	84.02% Impervious Area

Tc (min)	Length (feet)	Slope (ft/ft)	Velocity (ft/sec)	Capacity (cfs)	Description
5.0					Direct Entry,

Subcatchment 1S-2: Post

Hydrograph

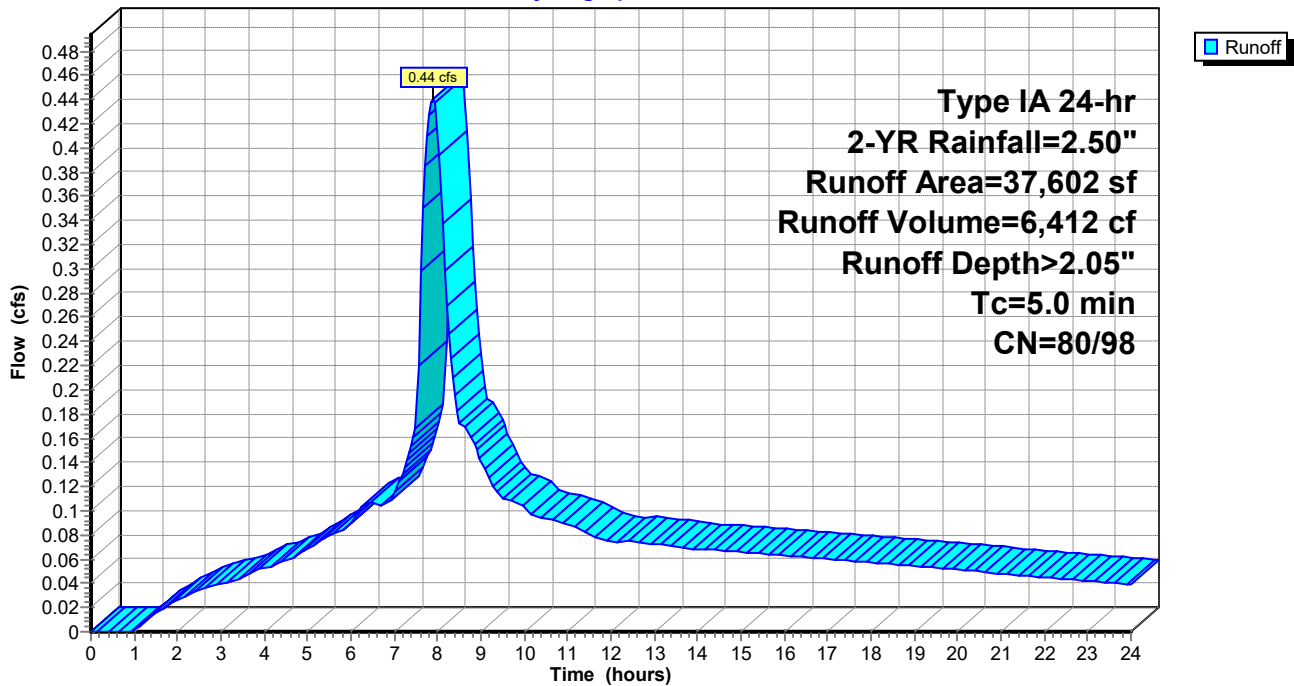

9656 Prelim Post-Developed

Prepared by AKS Engineering & Forestry, LLC

HydroCAD® 10.00-22 s/n 01338 © 2018 HydroCAD Software Solutions LLC

Type IA 24-hr 2-YR Rainfall=2.50"

Printed 7/28/2023

Summary for Subcatchment 1S-3: Post

Runoff = 0.01 cfs @ 8.86 hrs, Volume= 708 cf, Depth> 0.42"

Runoff by SBUH method, Split Pervious/Imperv., Time Span= 0.00-24.00 hrs, dt= 0.05 hrs
 Type IA 24-hr 2-YR Rainfall=2.50"

Area (sf)	CN	Description
10,627	65	Brush, Good, HSG C
9,750	73	Brush, Good, HSG D
20,377	69	Weighted Average
20,377	69	100.00% Pervious Area

Tc (min)	Length (feet)	Slope (ft/ft)	Velocity (ft/sec)	Capacity (cfs)	Description
10.0					Direct Entry,

Subcatchment 1S-3: Post

Hydrograph

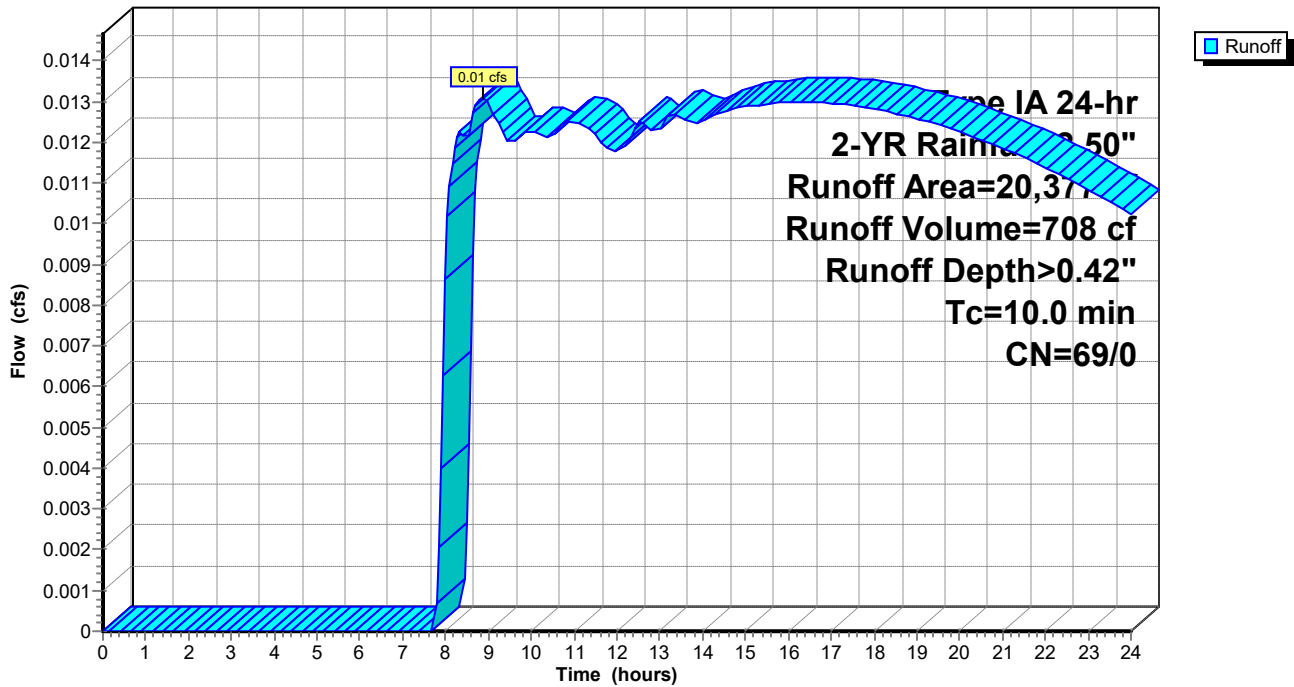

9656 Prelim Post-Developed

Type IA 24-hr 2-YR Rainfall=2.50"

Prepared by AKS Engineering & Forestry, LLC

Printed 7/28/2023

HydroCAD® 10.00-22 s/n 01338 © 2018 HydroCAD Software Solutions LLC

Summary for Pond 1S-2P: Stormwater Facility

Inflow Area = 37,602 sf, 84.02% Impervious, Inflow Depth > 2.05" for 2-YR event
 Inflow = 0.44 cfs @ 7.91 hrs, Volume= 6,412 cf
 Outflow = 0.10 cfs @ 10.01 hrs, Volume= 4,260 cf, Atten= 77%, Lag= 126.1 min
 Primary = 0.10 cfs @ 10.01 hrs, Volume= 4,260 cf

Routing by Dyn-Stor-Ind method, Time Span= 0.00-24.00 hrs, dt= 0.05 hrs
 Peak Elev= 171.90' @ 10.01 hrs Surf.Area= 1,640 sf Storage= 2,554 cf

Plug-Flow detention time= 395.9 min calculated for 4,251 cf (66% of inflow)
 Center-of-Mass det. time= 194.1 min (878.9 - 684.8)

Volume	Invert	Avail.Storage	Storage Description
#1	169.50'	5,893 cf	Custom Stage Data (Prismatic) Listed below (Recalc)

Elevation (feet)	Surf.Area (sq-ft)	Voids (%)	Inc.Store (cubic-feet)	Cum.Store (cubic-feet)
169.50	550	0.0	0	0
170.50	955	100.0	753	753
171.50	1,430	100.0	1,193	1,945
172.50	1,960	100.0	1,695	3,640
173.50	2,545	100.0	2,253	5,893

Device	Routing	Invert	Outlet Devices
#1	Primary	169.30'	12.0" Round Culvert L= 65.0' Ke= 0.620 Inlet / Outlet Invert= 169.30' / 169.00' S= 0.0046 '/' Cc= 0.900 n= 0.013, Flow Area= 0.79 sf
#2	Device 1	169.50'	0.5" Vert. Orifice/Grate C= 0.620
#3	Device 1	171.50'	2.5" Vert. Detention Orifice C= 0.620
#4	Primary	172.40'	2.2' long (Profile 17) Broad-Crested Rectangular Weir Head (feet) 0.49 0.98 1.48 1.97 2.46 2.95 Coef. (English) 2.84 3.13 3.26 3.30 3.31 3.31

Primary OutFlow Max=0.10 cfs @ 10.01 hrs HW=171.90' TW=0.00' (Dynamic Tailwater)

- 1=Culvert (Passes 0.10 cfs of 4.54 cfs potential flow)
- 2=Orifice/Grate (Orifice Controls 0.01 cfs @ 7.67 fps)
- 3=Detention Orifice (Orifice Controls 0.09 cfs @ 2.69 fps)
- 4=Broad-Crested Rectangular Weir (Controls 0.00 cfs)

Pond 1S-2P: Stormwater Facility

Hydrograph

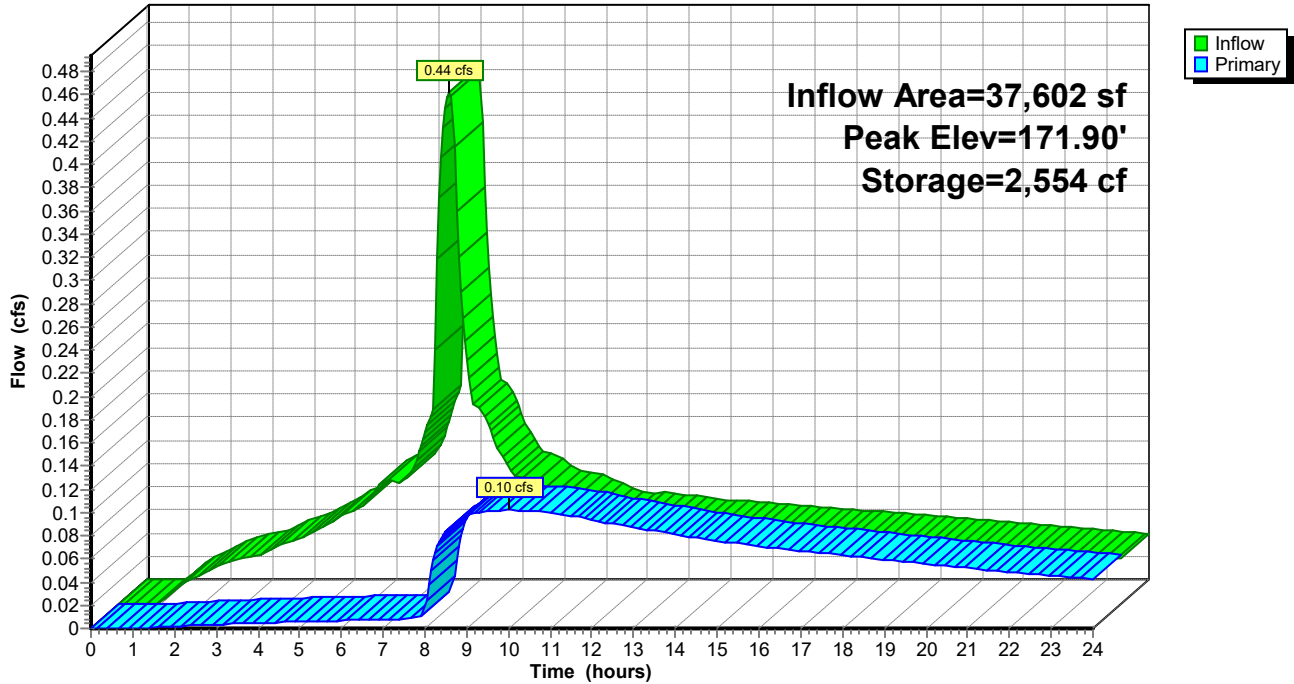

9656 Prelim Post-Developed

Prepared by AKS Engineering & Forestry, LLC

HydroCAD® 10.00-22 s/n 01338 © 2018 HydroCAD Software Solutions LLC

Type IA 24-hr 2-YR Rainfall=2.50"

Printed 7/28/2023

Summary for Pond UD: Pipe Storage

Inflow Area = 44,783 sf, 83.50% Impervious, Inflow Depth > 2.04" for 2-YR event
 Inflow = 0.52 cfs @ 7.91 hrs, Volume= 7,610 cf
 Outflow = 0.12 cfs @ 10.07 hrs, Volume= 4,237 cf, Atten= 77%, Lag= 129.5 min
 Primary = 0.12 cfs @ 10.07 hrs, Volume= 4,237 cf

Routing by Dyn-Stor-Ind method, Time Span= 0.00-24.00 hrs, dt= 0.05 hrs
 Peak Elev= 171.29' @ 10.07 hrs Surf.Area= 1,017 sf Storage= 3,461 cf

Plug-Flow detention time= 474.1 min calculated for 4,237 cf (56% of inflow)
 Center-of-Mass det. time= 226.7 min (911.9 - 685.2)

Volume	Invert	Avail.Storage	Storage Description
#1	168.00'	4,021 cf	48.0" Round CMP_Round 48" x 2 L= 160.0' S= 0.0010 1/1'

Device	Routing	Invert	Outlet Devices
#1	Primary	168.00'	12.0" Round Culvert L= 80.0' Ke= 0.600 Inlet / Outlet Invert= 168.00' / 166.18' S= 0.0227 1/1' Cc= 0.900 n= 0.013, Flow Area= 0.79 sf
#2	Device 1	168.00'	0.5" Horiz. Orifice/Grate C= 0.620 Limited to weir flow at low heads
#3	Device 1	171.10'	6.0" Vert. Orifice/Grate C= 0.620
#4	Device 1	172.00'	12.0" Horiz. Orifice/Grate C= 0.620 Limited to weir flow at low heads

Primary OutFlow Max=0.12 cfs @ 10.07 hrs HW=171.29' TW=0.00' (Dynamic Tailwater)

- 1=Culvert (Passes 0.12 cfs of 5.92 cfs potential flow)
- 2=Orifice/Grate (Orifice Controls 0.01 cfs @ 9.03 fps)
- 3=Orifice/Grate (Orifice Controls 0.11 cfs @ 1.54 fps)
- 4=Orifice/Grate (Controls 0.00 cfs)

Pond UD: Pipe Storage

Hydrograph

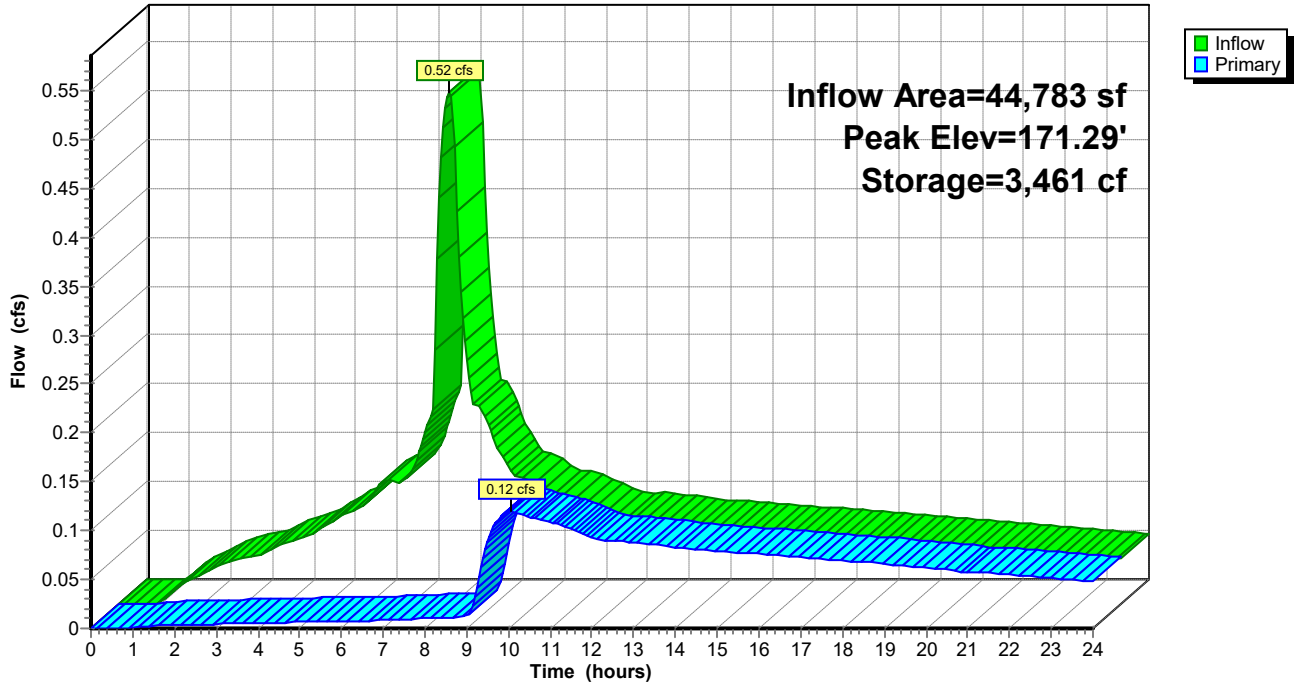

9656 Prelim Post-Developed

Prepared by AKS Engineering & Forestry, LLC

HydroCAD® 10.00-22 s/n 01338 © 2018 HydroCAD Software Solutions LLC

Type IA 24-hr 2-YR Rainfall=2.50"

Printed 7/28/2023

Summary for Link Post: Total

Inflow Area = 102,762 sf, 67.14% Impervious, Inflow Depth > 1.07" for 2-YR event
Inflow = 0.23 cfs @ 10.06 hrs, Volume= 9,205 cf
Primary = 0.23 cfs @ 10.06 hrs, Volume= 9,205 cf, Atten= 0%, Lag= 0.0 min

Primary outflow = Inflow, Time Span= 0.00-24.00 hrs, dt= 0.05 hrs

Link Post: Total

Hydrograph

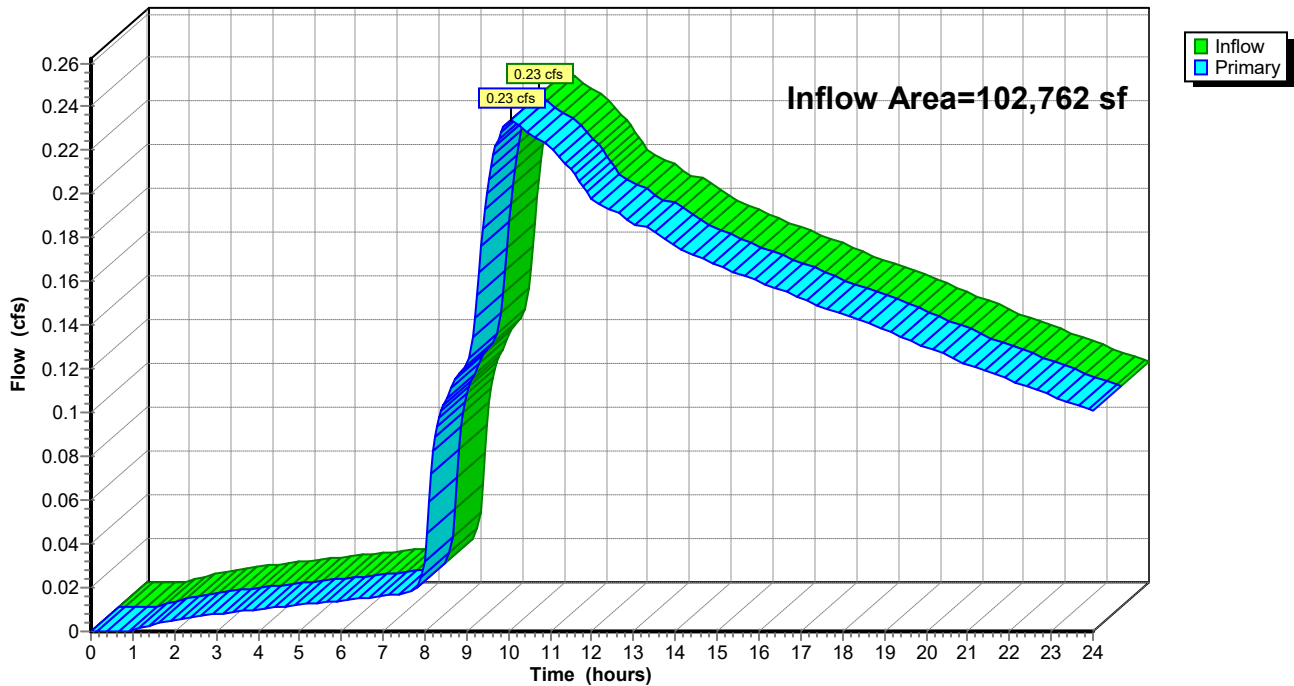

9656 Prelim Post-Developed

Type IA 24-hr 5-YR Rainfall=3.10"

Prepared by AKS Engineering & Forestry, LLC

Printed 7/28/2023

HydroCAD® 10.00-22 s/n 01338 © 2018 HydroCAD Software Solutions LLC

Time span=0.00-24.00 hrs, dt=0.05 hrs, 481 points

Runoff by SBUH method, Split Pervious/Imperv.

Reach routing by Dyn-Stor-Ind method - Pond routing by Dyn-Stor-Ind method

Subcatchment 1S-1: Post	Runoff Area=44,783 sf 83.50% Impervious Runoff Depth>2.61" Tc=5.0 min CN=80/98 Runoff=0.67 cfs 9,736 cf
Subcatchment 1S-2: Post	Runoff Area=37,602 sf 84.02% Impervious Runoff Depth>2.62" Tc=5.0 min CN=80/98 Runoff=0.56 cfs 8,200 cf
Subcatchment 1S-3: Post	Runoff Area=20,377 sf 0.00% Impervious Runoff Depth>0.72" Tc=10.0 min CN=69/0 Runoff=0.04 cfs 1,220 cf
Pond 1S-2P: Stormwater Facility	Peak Elev=172.21' Storage=3,103 cf Inflow=0.56 cfs 8,200 cf Outflow=0.14 cfs 5,997 cf
Pond UD: Pipe Storage	Peak Elev=171.41' Storage=3,578 cf Inflow=0.67 cfs 9,736 cf Outflow=0.26 cfs 6,346 cf
Link Post: Total	Inflow=0.43 cfs 13,564 cf Primary=0.43 cfs 13,564 cf

Total Runoff Area = 102,762 sf Runoff Volume = 19,155 cf Average Runoff Depth = 2.24"
32.86% Pervious = 33,772 sf 67.14% Impervious = 68,990 sf

9656 Prelim Post-Developed

Prepared by AKS Engineering & Forestry, LLC

HydroCAD® 10.00-22 s/n 01338 © 2018 HydroCAD Software Solutions LLC

Type IA 24-hr 5-YR Rainfall=3.10"

Printed 7/28/2023

Summary for Subcatchment 1S-1: Post

Runoff = 0.67 cfs @ 7.91 hrs, Volume= 9,736 cf, Depth> 2.61"

Runoff by SBUH method, Split Pervious/Imperv., Time Span= 0.00-24.00 hrs, dt= 0.05 hrs
Type IA 24-hr 5-YR Rainfall=3.10"

Area (sf)	CN	Description
37,396	98	Paved parking, HSG D
7,387	80	>75% Grass cover, Good, HSG D
44,783	95	Weighted Average
7,387	80	16.50% Pervious Area
37,396	98	83.50% Impervious Area

Tc (min)	Length (feet)	Slope (ft/ft)	Velocity (ft/sec)	Capacity (cfs)	Description
5.0					Direct Entry,

Subcatchment 1S-1: Post

Hydrograph

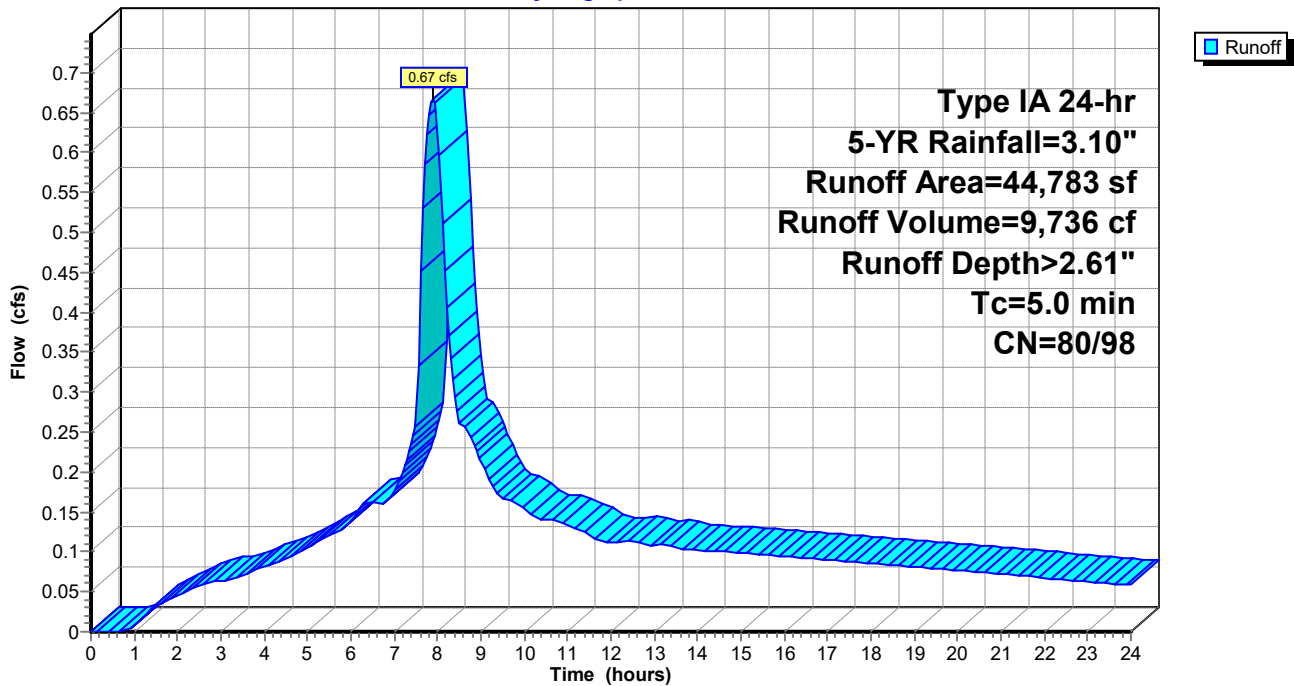

9656 Prelim Post-Developed

Prepared by AKS Engineering & Forestry, LLC

HydroCAD® 10.00-22 s/n 01338 © 2018 HydroCAD Software Solutions LLC

Type IA 24-hr 5-YR Rainfall=3.10"

Printed 7/28/2023

Summary for Subcatchment 1S-2: Post

Runoff = 0.56 cfs @ 7.91 hrs, Volume= 8,200 cf, Depth> 2.62"

Runoff by SBUH method, Split Pervious/Imperv., Time Span= 0.00-24.00 hrs, dt= 0.05 hrs
Type IA 24-hr 5-YR Rainfall=3.10"

Area (sf)	CN	Description
31,594	98	Paved parking, HSG D
6,008	80	>75% Grass cover, Good, HSG D
37,602	95	Weighted Average
6,008	80	15.98% Pervious Area
31,594	98	84.02% Impervious Area

Tc (min)	Length (feet)	Slope (ft/ft)	Velocity (ft/sec)	Capacity (cfs)	Description
5.0					Direct Entry,

Subcatchment 1S-2: Post

Hydrograph

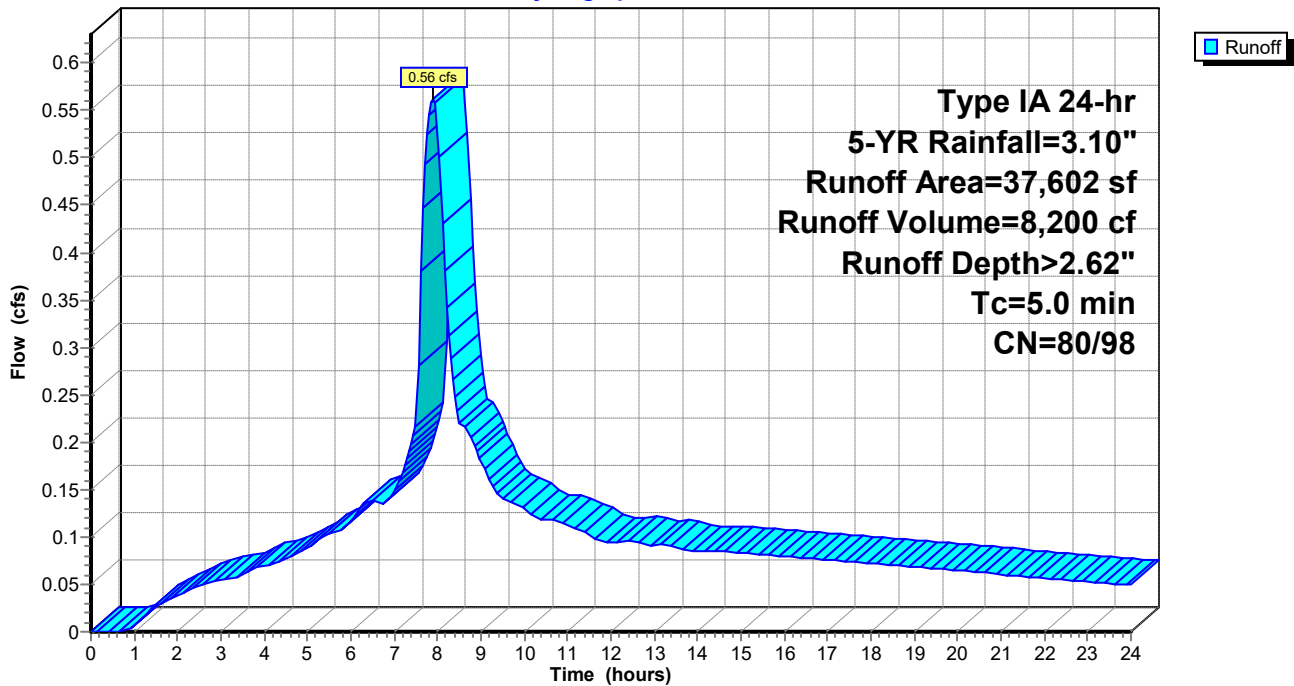

9656 Prelim Post-Developed

Prepared by AKS Engineering & Forestry, LLC

HydroCAD® 10.00-22 s/n 01338 © 2018 HydroCAD Software Solutions LLC

Type IA 24-hr 5-YR Rainfall=3.10"

Printed 7/28/2023

Summary for Subcatchment 1S-3: Post

Runoff = 0.04 cfs @ 8.05 hrs, Volume= 1,220 cf, Depth> 0.72"

Runoff by SBUH method, Split Pervious/Imperv., Time Span= 0.00-24.00 hrs, dt= 0.05 hrs
Type IA 24-hr 5-YR Rainfall=3.10"

Area (sf)	CN	Description
10,627	65	Brush, Good, HSG C
9,750	73	Brush, Good, HSG D
20,377	69	Weighted Average
20,377	69	100.00% Pervious Area

Tc (min)	Length (feet)	Slope (ft/ft)	Velocity (ft/sec)	Capacity (cfs)	Description
10.0					Direct Entry,

Subcatchment 1S-3: Post

Hydrograph

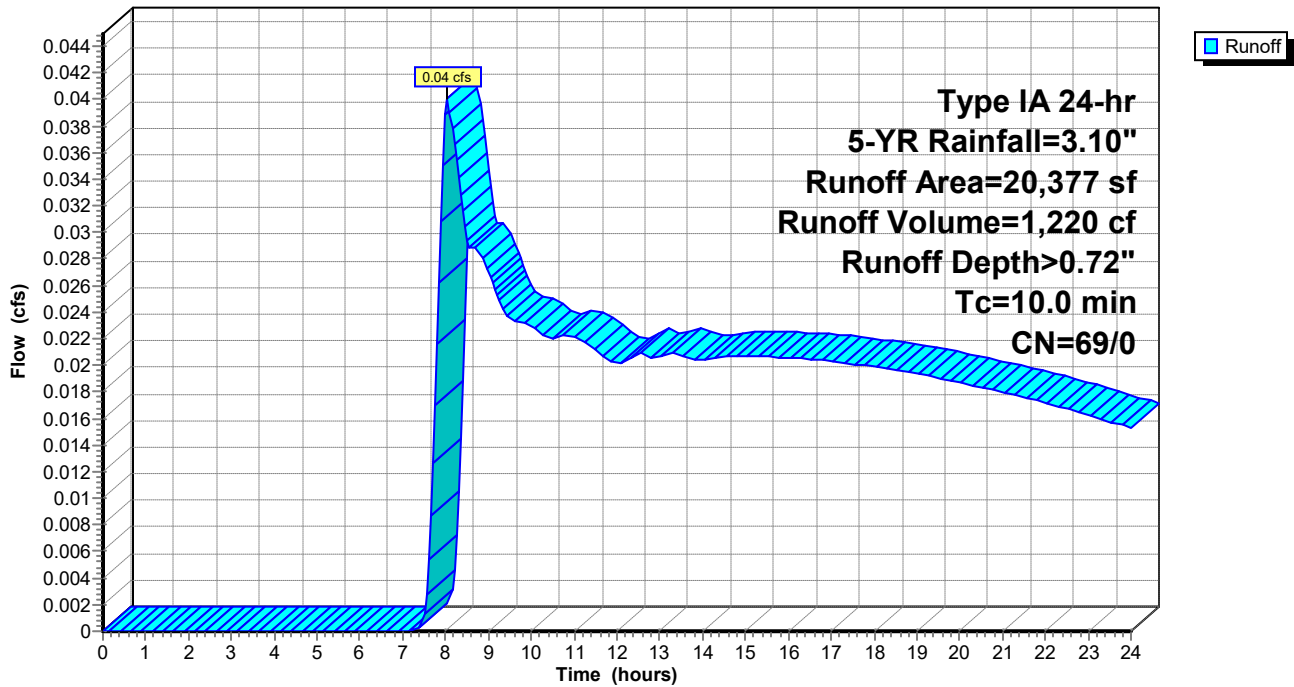

9656 Prelim Post-Developed

Type IA 24-hr 5-YR Rainfall=3.10"

Prepared by AKS Engineering & Forestry, LLC

Printed 7/28/2023

HydroCAD® 10.00-22 s/n 01338 © 2018 HydroCAD Software Solutions LLC

Summary for Pond 1S-2P: Stormwater Facility

Inflow Area = 37,602 sf, 84.02% Impervious, Inflow Depth > 2.62" for 5-YR event
 Inflow = 0.56 cfs @ 7.91 hrs, Volume= 8,200 cf
 Outflow = 0.14 cfs @ 9.42 hrs, Volume= 5,997 cf, Atten= 74%, Lag= 90.7 min
 Primary = 0.14 cfs @ 9.42 hrs, Volume= 5,997 cf

Routing by Dyn-Stor-Ind method, Time Span= 0.00-24.00 hrs, dt= 0.05 hrs
 Peak Elev= 172.21' @ 9.42 hrs Surf.Area= 1,809 sf Storage= 3,103 cf

Plug-Flow detention time= 356.0 min calculated for 5,985 cf (73% of inflow)
 Center-of-Mass det. time= 186.5 min (865.2 - 678.7)

Volume	Invert	Avail.Storage	Storage Description
#1	169.50'	5,893 cf	Custom Stage Data (Prismatic) Listed below (Recalc)

Elevation (feet)	Surf.Area (sq-ft)	Voids (%)	Inc.Store (cubic-feet)	Cum.Store (cubic-feet)
169.50	550	0.0	0	0
170.50	955	100.0	753	753
171.50	1,430	100.0	1,193	1,945
172.50	1,960	100.0	1,695	3,640
173.50	2,545	100.0	2,253	5,893

Device	Routing	Invert	Outlet Devices
#1	Primary	169.30'	12.0" Round Culvert L= 65.0' Ke= 0.620 Inlet / Outlet Invert= 169.30' / 169.00' S= 0.0046 '/' Cc= 0.900 n= 0.013, Flow Area= 0.79 sf
#2	Device 1	169.50'	0.5" Vert. Orifice/Grate C= 0.620
#3	Device 1	171.50'	2.5" Vert. Detention Orifice C= 0.620
#4	Primary	172.40'	2.2' long (Profile 17) Broad-Crested Rectangular Weir Head (feet) 0.49 0.98 1.48 1.97 2.46 2.95 Coef. (English) 2.84 3.13 3.26 3.30 3.31 3.31

Primary OutFlow Max=0.14 cfs @ 9.42 hrs HW=172.21' TW=0.00' (Dynamic Tailwater)

- 1=Culvert (Passes 0.14 cfs of 4.90 cfs potential flow)
- 2=Orifice/Grate (Orifice Controls 0.01 cfs @ 8.17 fps)
- 3=Detention Orifice (Orifice Controls 0.13 cfs @ 3.89 fps)
- 4=Broad-Crested Rectangular Weir (Controls 0.00 cfs)

Pond 1S-2P: Stormwater Facility

Hydrograph

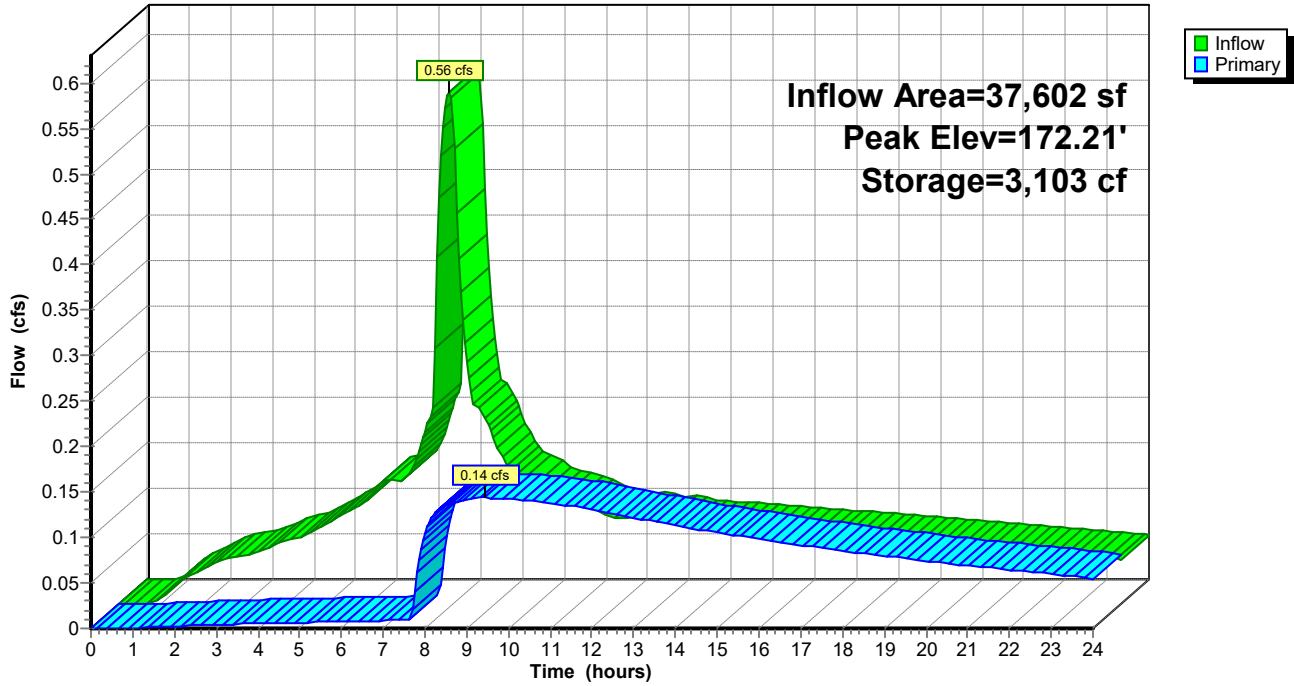

9656 Prelim Post-Developed

Type IA 24-hr 5-YR Rainfall=3.10"

Prepared by AKS Engineering & Forestry, LLC

Printed 7/28/2023

HydroCAD® 10.00-22 s/n 01338 © 2018 HydroCAD Software Solutions LLC

Summary for Pond UD: Pipe Storage

Inflow Area = 44,783 sf, 83.50% Impervious, Inflow Depth > 2.61" for 5-YR event
 Inflow = 0.67 cfs @ 7.91 hrs, Volume= 9,736 cf
 Outflow = 0.26 cfs @ 8.50 hrs, Volume= 6,346 cf, Atten= 60%, Lag= 35.6 min
 Primary = 0.26 cfs @ 8.50 hrs, Volume= 6,346 cf

Routing by Dyn-Stor-Ind method, Time Span= 0.00-24.00 hrs, dt= 0.05 hrs
 Peak Elev= 171.41' @ 8.50 hrs Surf.Area= 955 sf Storage= 3,578 cf

Plug-Flow detention time= 380.2 min calculated for 6,333 cf (65% of inflow)
 Center-of-Mass det. time= 172.1 min (851.3 - 679.2)

Volume	Invert	Avail.Storage	Storage Description
#1	168.00'	4,021 cf	48.0" Round CMP_Round 48" x 2 L= 160.0' S= 0.0010 '/'

Device	Routing	Invert	Outlet Devices
#1	Primary	168.00'	12.0" Round Culvert L= 80.0' Ke= 0.600 Inlet / Outlet Invert= 168.00' / 166.18' S= 0.0227 '/ Cc= 0.900 n= 0.013, Flow Area= 0.79 sf
#2	Device 1	168.00'	0.5" Horiz. Orifice/Grate C= 0.620 Limited to weir flow at low heads
#3	Device 1	171.10'	6.0" Vert. Orifice/Grate C= 0.620
#4	Device 1	172.00'	12.0" Horiz. Orifice/Grate C= 0.620 Limited to weir flow at low heads

Primary OutFlow Max=0.26 cfs @ 8.50 hrs HW=171.41' TW=0.00' (Dynamic Tailwater)

- 1=Culvert (Passes 0.26 cfs of 6.05 cfs potential flow)
- 2=Orifice/Grate (Orifice Controls 0.01 cfs @ 9.19 fps)
- 3=Orifice/Grate (Orifice Controls 0.25 cfs @ 1.96 fps)
- 4=Orifice/Grate (Controls 0.00 cfs)

Pond UD: Pipe Storage

Hydrograph

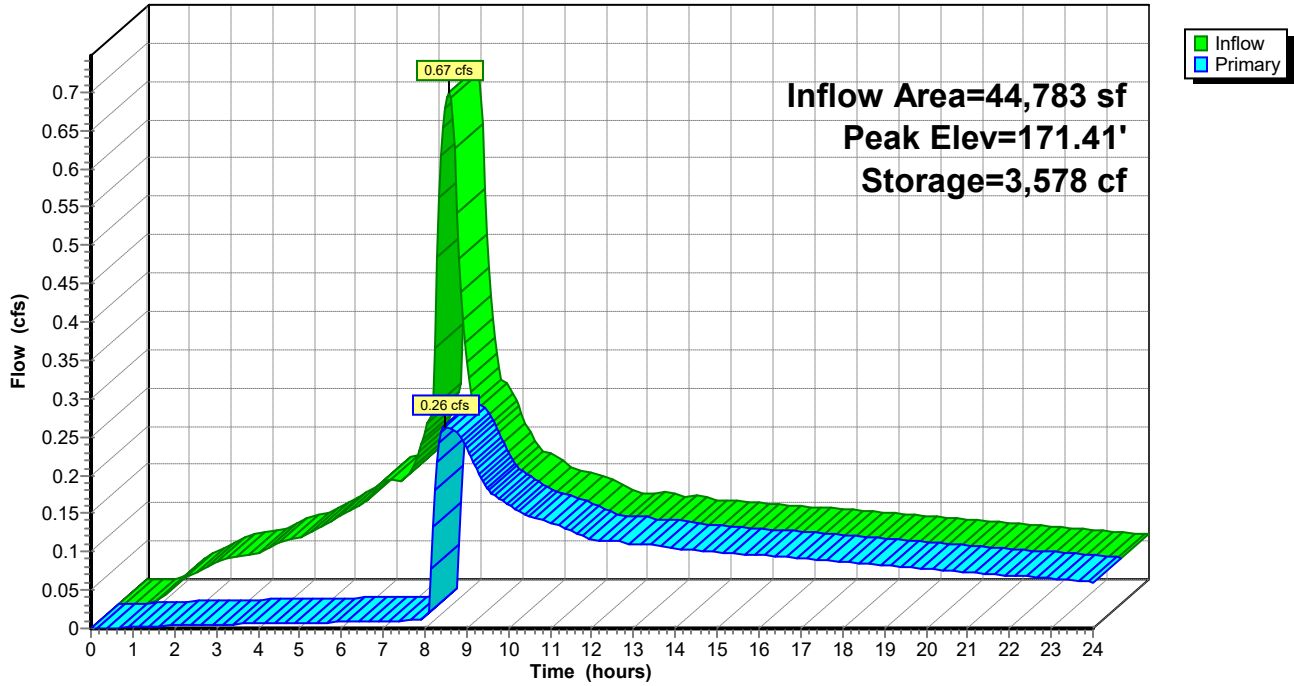

9656 Prelim Post-Developed

Prepared by AKS Engineering & Forestry, LLC

HydroCAD® 10.00-22 s/n 01338 © 2018 HydroCAD Software Solutions LLC

Type IA 24-hr 5-YR Rainfall=3.10"

Printed 7/28/2023

Summary for Link Post: Total

Inflow Area = 102,762 sf, 67.14% Impervious, Inflow Depth > 1.58" for 5-YR event
Inflow = 0.43 cfs @ 8.51 hrs, Volume= 13,564 cf
Primary = 0.43 cfs @ 8.51 hrs, Volume= 13,564 cf, Atten= 0%, Lag= 0.0 min

Primary outflow = Inflow, Time Span= 0.00-24.00 hrs, dt= 0.05 hrs

Link Post: Total

Hydrograph

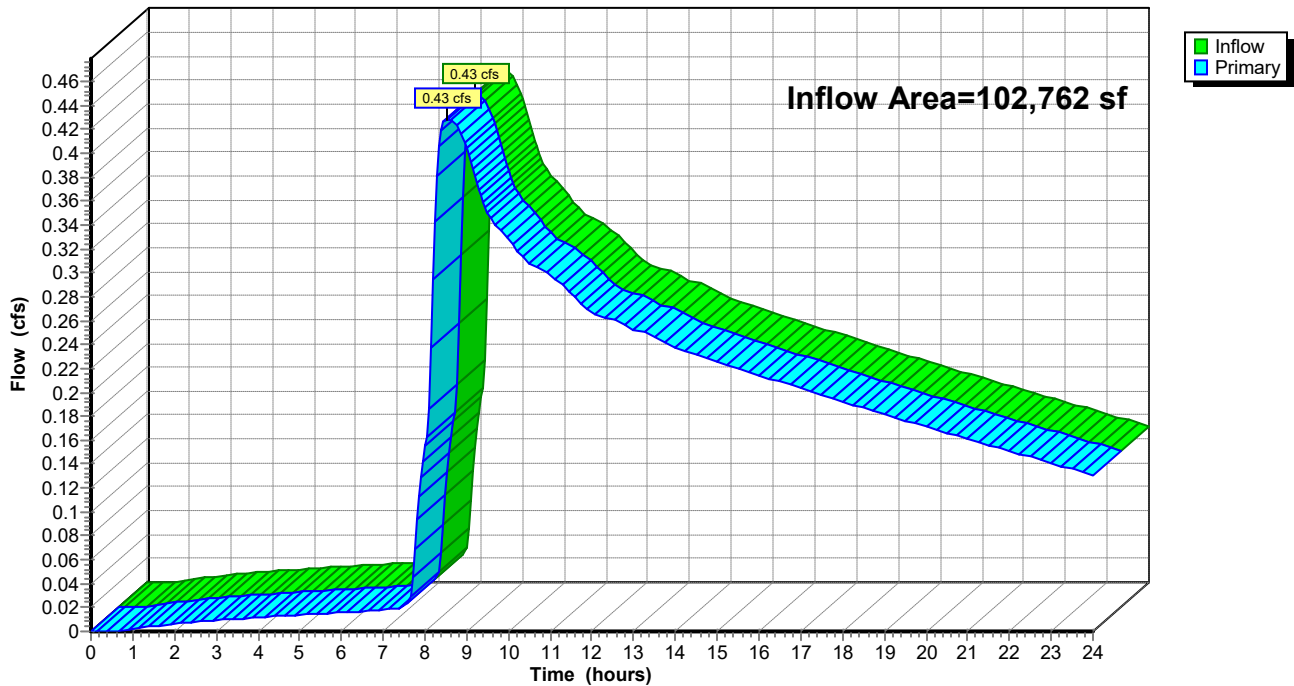

9656 Prelim Post-Developed

Type IA 24-hr 10-YR Rainfall=3.45"

Prepared by AKS Engineering & Forestry, LLC

Printed 7/28/2023

HydroCAD® 10.00-22 s/n 01338 © 2018 HydroCAD Software Solutions LLC

Time span=0.00-24.00 hrs, dt=0.05 hrs, 481 points

Runoff by SBUH method, Split Pervious/Imperv.

Reach routing by Dyn-Stor-Ind method - Pond routing by Dyn-Stor-Ind method

Subcatchment 1S-1: Post	Runoff Area=44,783 sf 83.50% Impervious Runoff Depth>2.94" Tc=5.0 min CN=80/98 Runoff=0.75 cfs 10,987 cf
Subcatchment 1S-2: Post	Runoff Area=37,602 sf 84.02% Impervious Runoff Depth>2.95" Tc=5.0 min CN=80/98 Runoff=0.63 cfs 9,252 cf
Subcatchment 1S-3: Post	Runoff Area=20,377 sf 0.00% Impervious Runoff Depth>0.92" Tc=10.0 min CN=69/0 Runoff=0.06 cfs 1,558 cf
Pond 1S-2P: Stormwater Facility	Peak Elev=172.41' Storage=3,459 cf Inflow=0.63 cfs 9,252 cf Outflow=0.17 cfs 7,006 cf
Pond UD: Pipe Storage	Peak Elev=171.55' Storage=3,702 cf Inflow=0.75 cfs 10,987 cf Outflow=0.45 cfs 7,586 cf
Link Post: Total	Inflow=0.65 cfs 16,150 cf Primary=0.65 cfs 16,150 cf

Total Runoff Area = 102,762 sf Runoff Volume = 21,798 cf Average Runoff Depth = 2.55"
32.86% Pervious = 33,772 sf 67.14% Impervious = 68,990 sf

9656 Prelim Post-Developed

Prepared by AKS Engineering & Forestry, LLC

HydroCAD® 10.00-22 s/n 01338 © 2018 HydroCAD Software Solutions LLC

Type IA 24-hr 10-YR Rainfall=3.45"

Printed 7/28/2023

Summary for Subcatchment 1S-1: Post

Runoff = 0.75 cfs @ 7.91 hrs, Volume= 10,987 cf, Depth> 2.94"

Runoff by SBUH method, Split Pervious/Imperv., Time Span= 0.00-24.00 hrs, dt= 0.05 hrs
Type IA 24-hr 10-YR Rainfall=3.45"

Area (sf)	CN	Description
37,396	98	Paved parking, HSG D
7,387	80	>75% Grass cover, Good, HSG D
44,783	95	Weighted Average
7,387	80	16.50% Pervious Area
37,396	98	83.50% Impervious Area

Tc (min)	Length (feet)	Slope (ft/ft)	Velocity (ft/sec)	Capacity (cfs)	Description
5.0					Direct Entry,

Subcatchment 1S-1: Post

Hydrograph

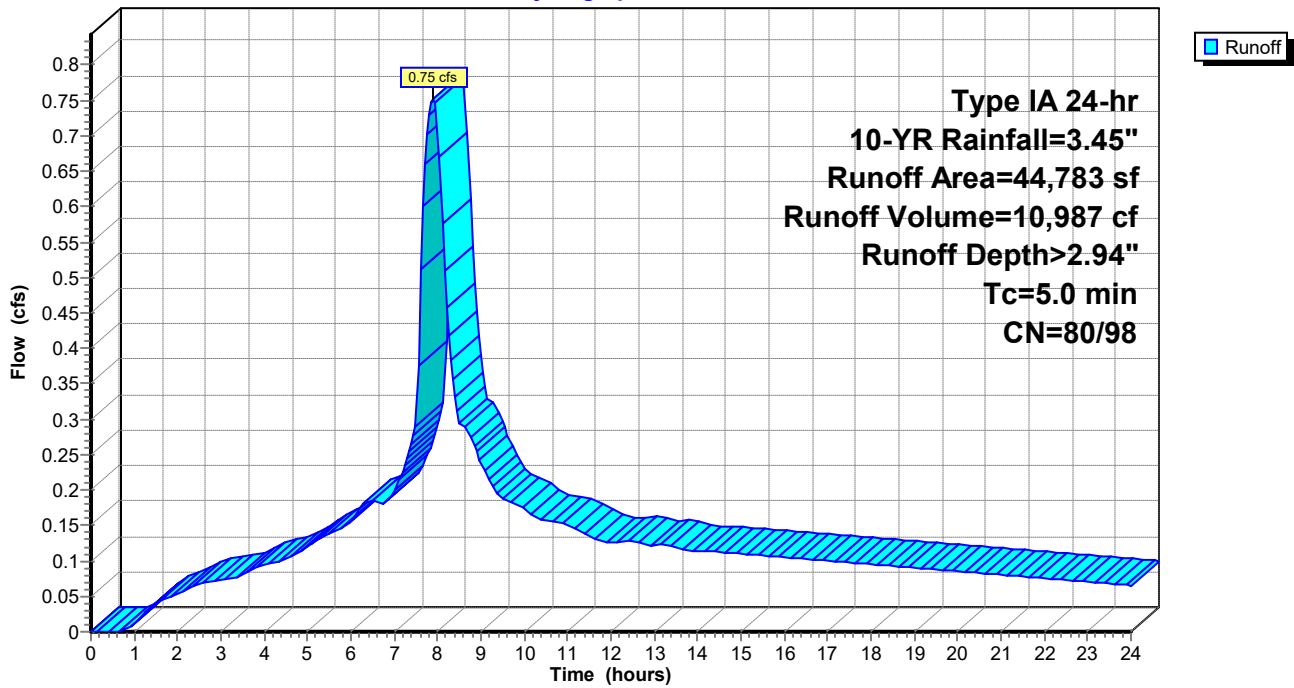

9656 Prelim Post-Developed

Prepared by AKS Engineering & Forestry, LLC

HydroCAD® 10.00-22 s/n 01338 © 2018 HydroCAD Software Solutions LLC

Type IA 24-hr 10-YR Rainfall=3.45"

Printed 7/28/2023

Summary for Subcatchment 1S-2: Post

Runoff = 0.63 cfs @ 7.91 hrs, Volume= 9,252 cf, Depth> 2.95"

Runoff by SBUH method, Split Pervious/Imperv., Time Span= 0.00-24.00 hrs, dt= 0.05 hrs
Type IA 24-hr 10-YR Rainfall=3.45"

Area (sf)	CN	Description
31,594	98	Paved parking, HSG D
6,008	80	>75% Grass cover, Good, HSG D
37,602	95	Weighted Average
6,008	80	15.98% Pervious Area
31,594	98	84.02% Impervious Area

Tc (min)	Length (feet)	Slope (ft/ft)	Velocity (ft/sec)	Capacity (cfs)	Description
5.0					Direct Entry,

Subcatchment 1S-2: Post

Hydrograph

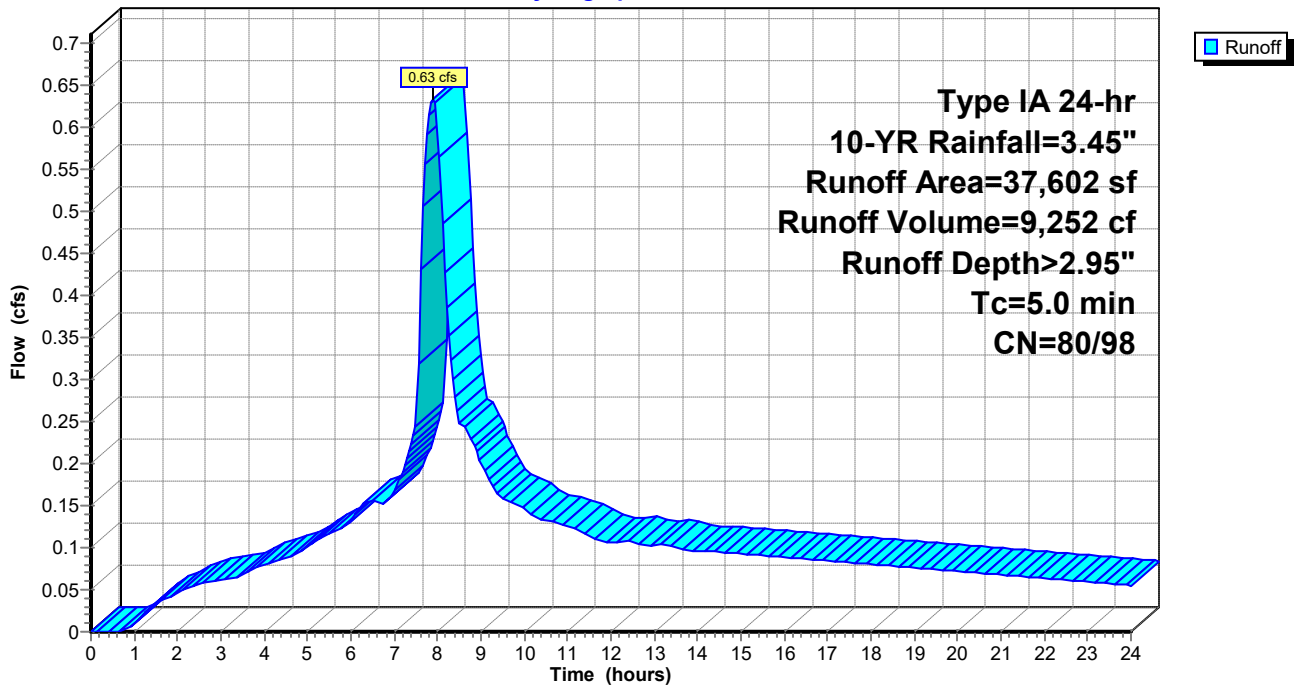

9656 Prelim Post-Developed

Prepared by AKS Engineering & Forestry, LLC

HydroCAD® 10.00-22 s/n 01338 © 2018 HydroCAD Software Solutions LLC

Type IA 24-hr 10-YR Rainfall=3.45"

Printed 7/28/2023

Summary for Subcatchment 1S-3: Post

Runoff = 0.06 cfs @ 8.03 hrs, Volume= 1,558 cf, Depth> 0.92"

Runoff by SBUH method, Split Pervious/Imperv., Time Span= 0.00-24.00 hrs, dt= 0.05 hrs
Type IA 24-hr 10-YR Rainfall=3.45"

Area (sf)	CN	Description
10,627	65	Brush, Good, HSG C
9,750	73	Brush, Good, HSG D
20,377	69	Weighted Average
20,377	69	100.00% Pervious Area

Tc (min)	Length (feet)	Slope (ft/ft)	Velocity (ft/sec)	Capacity (cfs)	Description
10.0					Direct Entry,

Subcatchment 1S-3: Post

Hydrograph

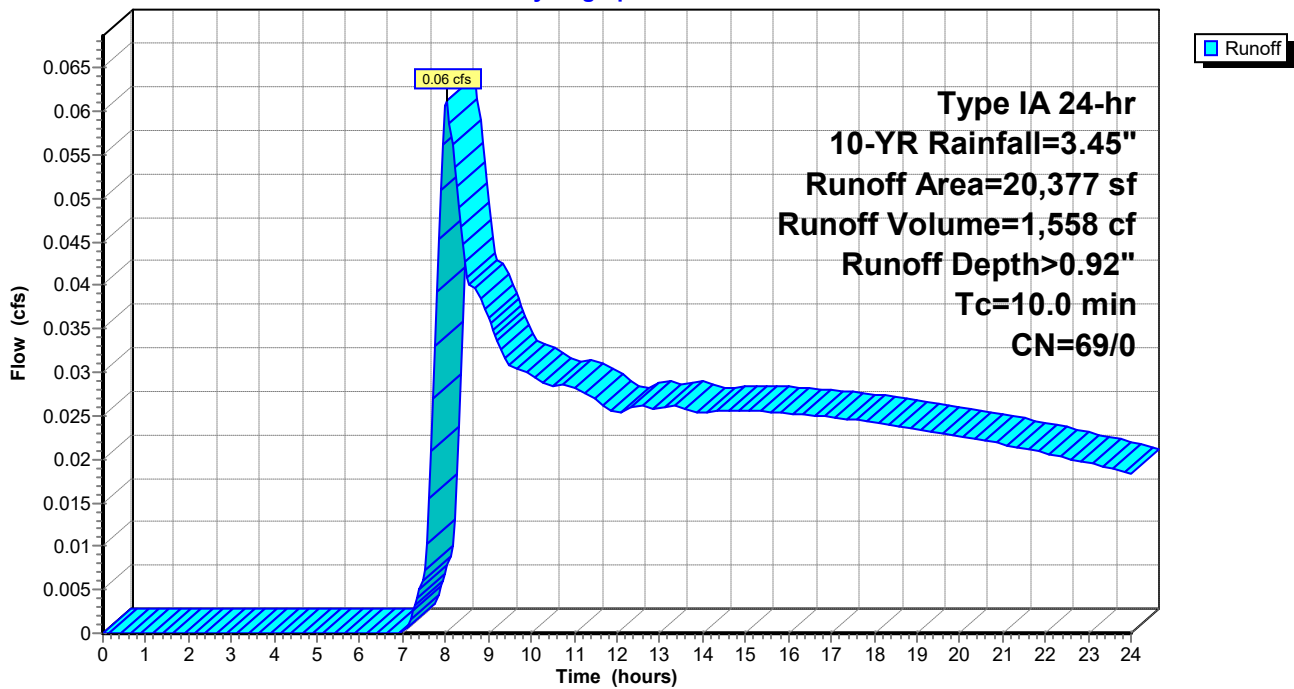

9656 Prelim Post-Developed

Type IA 24-hr 10-YR Rainfall=3.45"

Prepared by AKS Engineering & Forestry, LLC

Printed 7/28/2023

HydroCAD® 10.00-22 s/n 01338 © 2018 HydroCAD Software Solutions LLC

Summary for Pond 1S-2P: Stormwater Facility

Inflow Area = 37,602 sf, 84.02% Impervious, Inflow Depth > 2.95" for 10-YR event
 Inflow = 0.63 cfs @ 7.91 hrs, Volume= 9,252 cf
 Outflow = 0.17 cfs @ 9.34 hrs, Volume= 7,006 cf, Atten= 74%, Lag= 86.3 min
 Primary = 0.17 cfs @ 9.34 hrs, Volume= 7,006 cf

Routing by Dyn-Stor-Ind method, Time Span= 0.00-24.00 hrs, dt= 0.05 hrs
 Peak Elev= 172.41' @ 9.34 hrs Surf.Area= 1,910 sf Storage= 3,459 cf

Plug-Flow detention time= 344.8 min calculated for 7,006 cf (76% of inflow)
 Center-of-Mass det. time= 188.3 min (864.3 - 675.9)

Volume	Invert	Avail.Storage	Storage Description
#1	169.50'	5,893 cf	Custom Stage Data (Prismatic) Listed below (Recalc)

Elevation (feet)	Surf.Area (sq-ft)	Voids (%)	Inc.Store (cubic-feet)	Cum.Store (cubic-feet)
169.50	550	0.0	0	0
170.50	955	100.0	753	753
171.50	1,430	100.0	1,193	1,945
172.50	1,960	100.0	1,695	3,640
173.50	2,545	100.0	2,253	5,893

Device	Routing	Invert	Outlet Devices
#1	Primary	169.30'	12.0" Round Culvert L= 65.0' Ke= 0.620 Inlet / Outlet Invert= 169.30' / 169.00' S= 0.0046 '/' Cc= 0.900 n= 0.013, Flow Area= 0.79 sf
#2	Device 1	169.50'	0.5" Vert. Orifice/Grate C= 0.620
#3	Device 1	171.50'	2.5" Vert. Detention Orifice C= 0.620
#4	Primary	172.40'	2.2' long (Profile 17) Broad-Crested Rectangular Weir Head (feet) 0.49 0.98 1.48 1.97 2.46 2.95 Coef. (English) 2.84 3.13 3.26 3.30 3.31 3.31

Primary OutFlow Max=0.17 cfs @ 9.34 hrs HW=172.41' TW=0.00' (Dynamic Tailwater)

- 1=Culvert (Passes 0.16 cfs of 5.11 cfs potential flow)
- 2=Orifice/Grate (Orifice Controls 0.01 cfs @ 8.45 fps)
- 3=Detention Orifice (Orifice Controls 0.15 cfs @ 4.46 fps)
- 4=Broad-Crested Rectangular Weir (Weir Controls 0.00 cfs @ 0.23 fps)

Pond 1S-2P: Stormwater Facility

Hydrograph

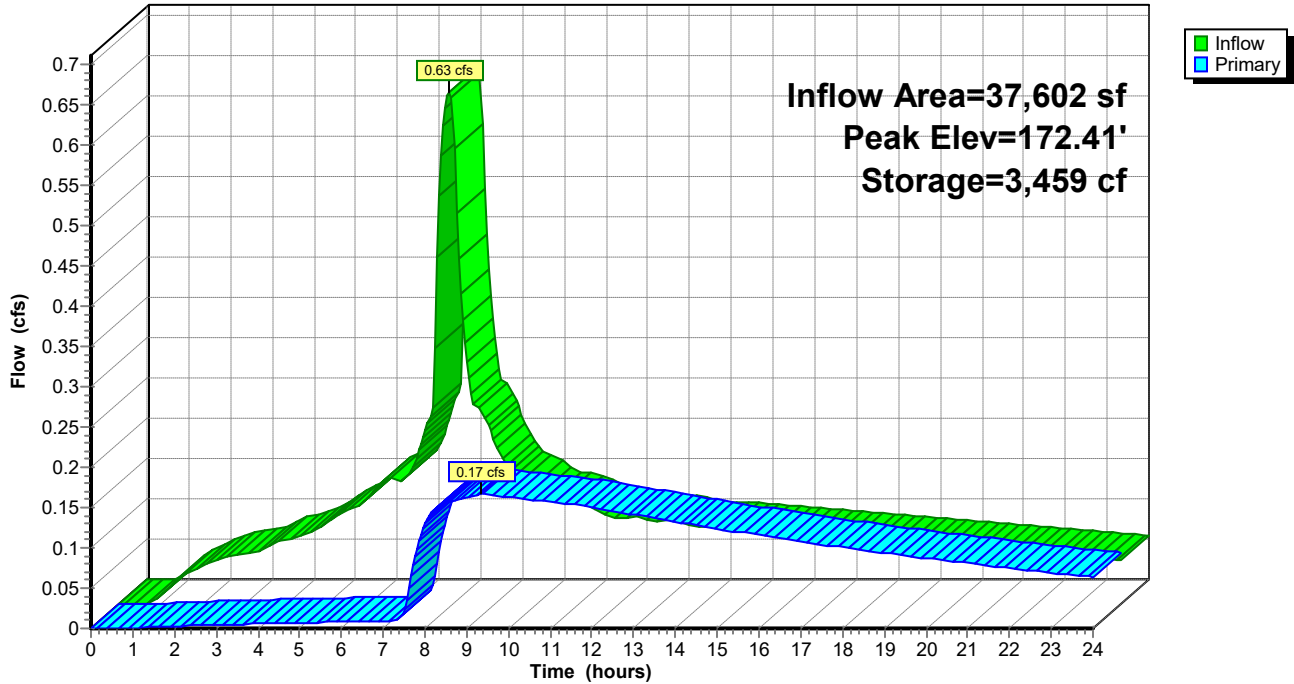

9656 Prelim Post-Developed

Type IA 24-hr 10-YR Rainfall=3.45"

Prepared by AKS Engineering & Forestry, LLC

Printed 7/28/2023

HydroCAD® 10.00-22 s/n 01338 © 2018 HydroCAD Software Solutions LLC

Summary for Pond UD: Pipe Storage

Inflow Area = 44,783 sf, 83.50% Impervious, Inflow Depth > 2.94" for 10-YR event
 Inflow = 0.75 cfs @ 7.91 hrs, Volume= 10,987 cf
 Outflow = 0.45 cfs @ 8.22 hrs, Volume= 7,586 cf, Atten= 41%, Lag= 18.6 min
 Primary = 0.45 cfs @ 8.22 hrs, Volume= 7,586 cf

Routing by Dyn-Stor-Ind method, Time Span= 0.00-24.00 hrs, dt= 0.05 hrs
 Peak Elev= 171.55' @ 8.22 hrs Surf.Area= 869 sf Storage= 3,702 cf

Plug-Flow detention time= 342.9 min calculated for 7,586 cf (69% of inflow)
 Center-of-Mass det. time= 152.1 min (828.5 - 676.4)

Volume	Invert	Avail.Storage	Storage Description
#1	168.00'	4,021 cf	48.0" Round CMP_Round 48" x 2 L= 160.0' S= 0.0010 '/

Device	Routing	Invert	Outlet Devices
#1	Primary	168.00'	12.0" Round Culvert L= 80.0' Ke= 0.600 Inlet / Outlet Invert= 168.00' / 166.18' S= 0.0227 '/ Cc= 0.900 n= 0.013, Flow Area= 0.79 sf
#2	Device 1	168.00'	0.5" Horiz. Orifice/Grate C= 0.620 Limited to weir flow at low heads
#3	Device 1	171.10'	6.0" Vert. Orifice/Grate C= 0.620
#4	Device 1	172.00'	12.0" Horiz. Orifice/Grate C= 0.620 Limited to weir flow at low heads

Primary OutFlow Max=0.45 cfs @ 8.22 hrs HW=171.55' TW=0.00' (Dynamic Tailwater)

- 1=Culvert (Passes 0.45 cfs of 6.19 cfs potential flow)
- 2=Orifice/Grate (Orifice Controls 0.01 cfs @ 9.37 fps)
- 3=Orifice/Grate (Orifice Controls 0.43 cfs @ 2.35 fps)
- 4=Orifice/Grate (Controls 0.00 cfs)

Pond UD: Pipe Storage

Hydrograph

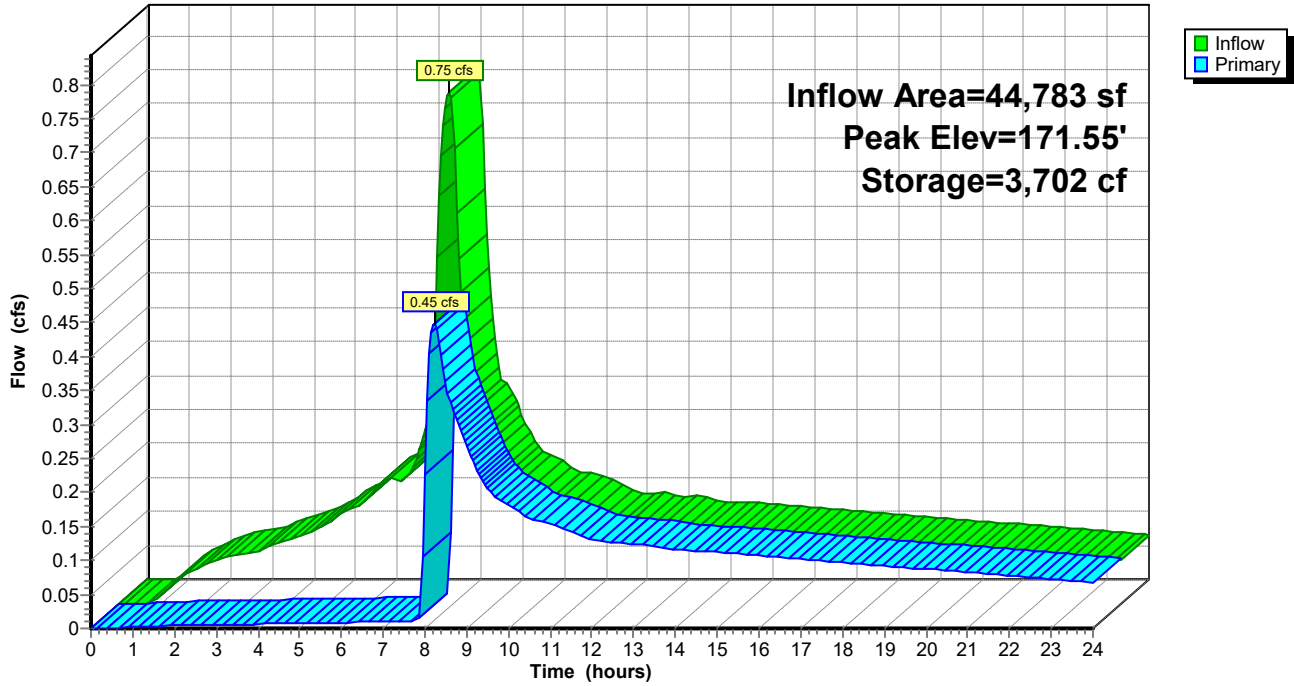

9656 Prelim Post-Developed

Prepared by AKS Engineering & Forestry, LLC

HydroCAD® 10.00-22 s/n 01338 © 2018 HydroCAD Software Solutions LLC

Type IA 24-hr 10-YR Rainfall=3.45"

Printed 7/28/2023

Summary for Link Post: Total

Inflow Area = 102,762 sf, 67.14% Impervious, Inflow Depth > 1.89" for 10-YR event
Inflow = 0.65 cfs @ 8.22 hrs, Volume= 16,150 cf
Primary = 0.65 cfs @ 8.22 hrs, Volume= 16,150 cf, Atten= 0%, Lag= 0.0 min

Primary outflow = Inflow, Time Span= 0.00-24.00 hrs, dt= 0.05 hrs

Link Post: Total

Hydrograph

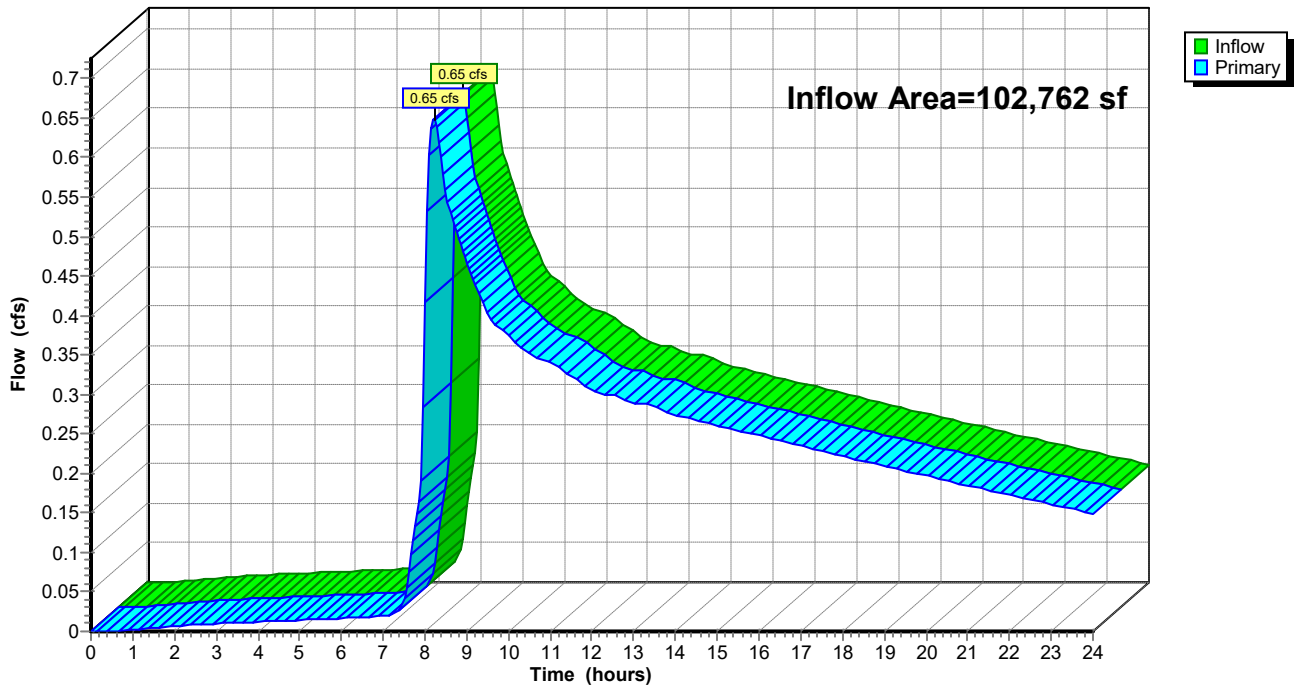

9656 Prelim Post-Developed

Prepared by AKS Engineering & Forestry, LLC

HydroCAD® 10.00-22 s/n 01338 © 2018 HydroCAD Software Solutions LLC

Type IA 24-hr 25-YR Rainfall=3.90"

Printed 7/28/2023

Time span=0.00-24.00 hrs, dt=0.05 hrs, 481 points
Runoff by SBUH method, Split Pervious/Imperv.
Reach routing by Dyn-Stor-Ind method - Pond routing by Dyn-Stor-Ind method

Subcatchment 1S-1: Post	Runoff Area=44,783 sf 83.50% Impervious Runoff Depth>3.38" Tc=5.0 min CN=80/98 Runoff=0.86 cfs 12,606 cf
Subcatchment 1S-2: Post	Runoff Area=37,602 sf 84.02% Impervious Runoff Depth>3.39" Tc=5.0 min CN=80/98 Runoff=0.73 cfs 10,613 cf
Subcatchment 1S-3: Post	Runoff Area=20,377 sf 0.00% Impervious Runoff Depth>1.19" Tc=10.0 min CN=69/0 Runoff=0.09 cfs 2,028 cf
Pond 1S-2P: Stormwater Facility	Peak Elev=172.48' Storage=3,601 cf Inflow=0.73 cfs 10,613 cf Outflow=0.31 cfs 8,295 cf
Pond UD: Pipe Storage	Peak Elev=171.78' Storage=3,882 cf Inflow=0.86 cfs 12,606 cf Outflow=0.65 cfs 9,194 cf
Link Post: Total	Inflow=0.95 cfs 19,517 cf Primary=0.95 cfs 19,517 cf

Total Runoff Area = 102,762 sf Runoff Volume = 25,247 cf Average Runoff Depth = 2.95"
32.86% Pervious = 33,772 sf 67.14% Impervious = 68,990 sf

9656 Prelim Post-Developed

Prepared by AKS Engineering & Forestry, LLC

HydroCAD® 10.00-22 s/n 01338 © 2018 HydroCAD Software Solutions LLC

Type IA 24-hr 25-YR Rainfall=3.90"

Printed 7/28/2023

Summary for Subcatchment 1S-1: Post

Runoff = 0.86 cfs @ 7.91 hrs, Volume= 12,606 cf, Depth> 3.38"

Runoff by SBUH method, Split Pervious/Imperv., Time Span= 0.00-24.00 hrs, dt= 0.05 hrs
 Type IA 24-hr 25-YR Rainfall=3.90"

Area (sf)	CN	Description
37,396	98	Paved parking, HSG D
7,387	80	>75% Grass cover, Good, HSG D
44,783	95	Weighted Average
7,387	80	16.50% Pervious Area
37,396	98	83.50% Impervious Area

Tc (min)	Length (feet)	Slope (ft/ft)	Velocity (ft/sec)	Capacity (cfs)	Description
5.0					Direct Entry,

Subcatchment 1S-1: Post

Hydrograph

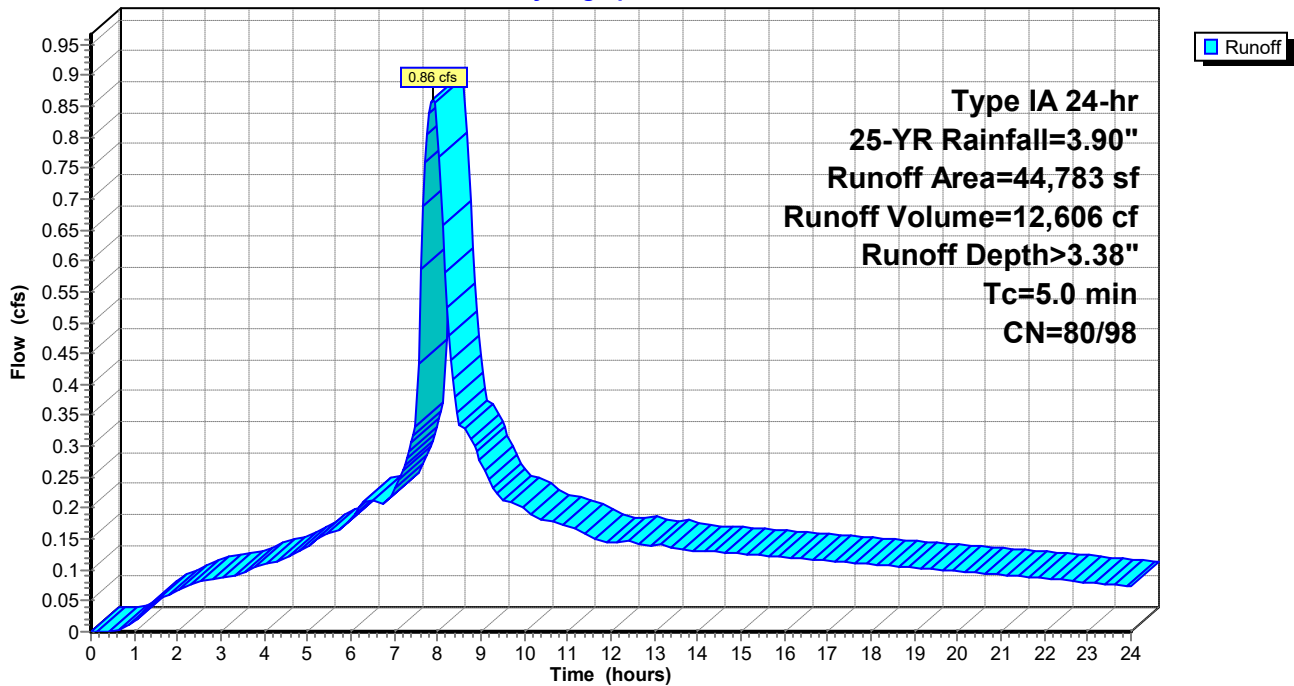

9656 Prelim Post-Developed

Prepared by AKS Engineering & Forestry, LLC

HydroCAD® 10.00-22 s/n 01338 © 2018 HydroCAD Software Solutions LLC

Type IA 24-hr 25-YR Rainfall=3.90"

Printed 7/28/2023

Summary for Subcatchment 1S-2: Post

Runoff = 0.73 cfs @ 7.91 hrs, Volume= 10,613 cf, Depth> 3.39"

Runoff by SBUH method, Split Pervious/Imperv., Time Span= 0.00-24.00 hrs, dt= 0.05 hrs
Type IA 24-hr 25-YR Rainfall=3.90"

Area (sf)	CN	Description
31,594	98	Paved parking, HSG D
6,008	80	>75% Grass cover, Good, HSG D
37,602	95	Weighted Average
6,008	80	15.98% Pervious Area
31,594	98	84.02% Impervious Area

Tc (min)	Length (feet)	Slope (ft/ft)	Velocity (ft/sec)	Capacity (cfs)	Description
5.0					Direct Entry,

Subcatchment 1S-2: Post

Hydrograph

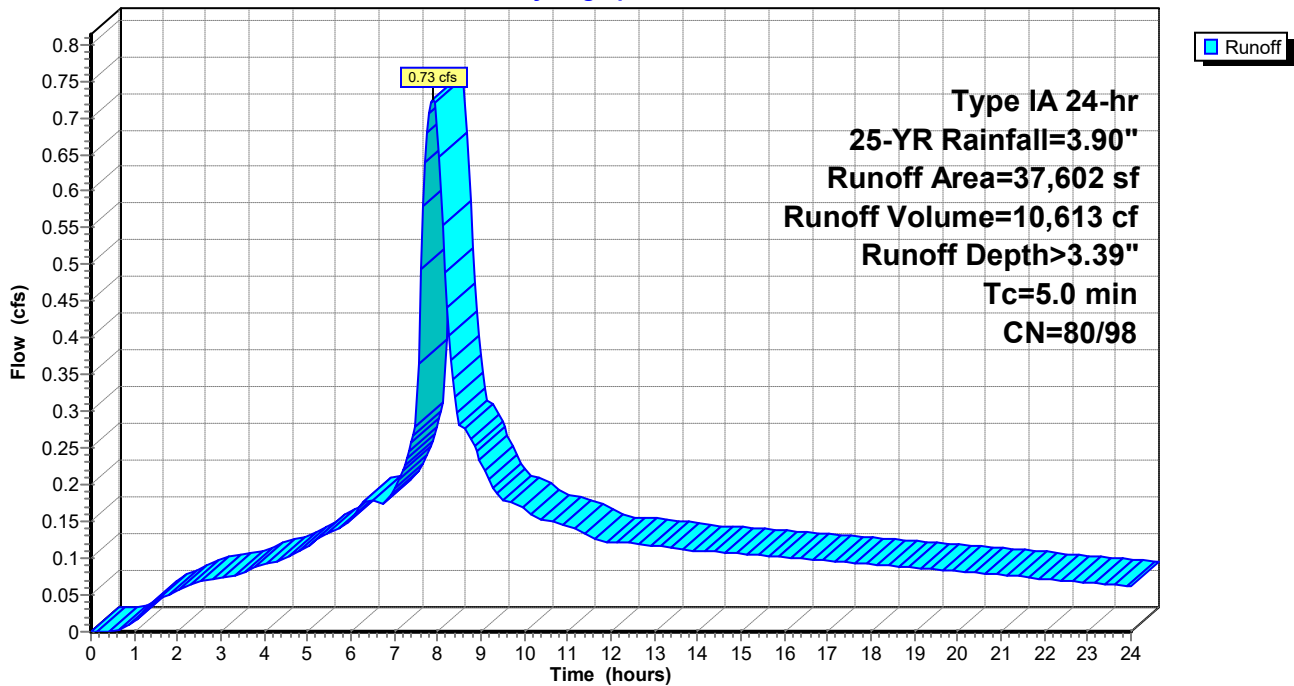

9656 Prelim Post-Developed

Prepared by AKS Engineering & Forestry, LLC

HydroCAD® 10.00-22 s/n 01338 © 2018 HydroCAD Software Solutions LLC

Type IA 24-hr 25-YR Rainfall=3.90"

Printed 7/28/2023

Summary for Subcatchment 1S-3: Post

Runoff = 0.09 cfs @ 8.02 hrs, Volume= 2,028 cf, Depth> 1.19"

Runoff by SBUH method, Split Pervious/Imperv., Time Span= 0.00-24.00 hrs, dt= 0.05 hrs
Type IA 24-hr 25-YR Rainfall=3.90"

Area (sf)	CN	Description
10,627	65	Brush, Good, HSG C
9,750	73	Brush, Good, HSG D
20,377	69	Weighted Average
20,377	69	100.00% Pervious Area

Tc (min)	Length (feet)	Slope (ft/ft)	Velocity (ft/sec)	Capacity (cfs)	Description
10.0					Direct Entry,

Subcatchment 1S-3: Post

Hydrograph

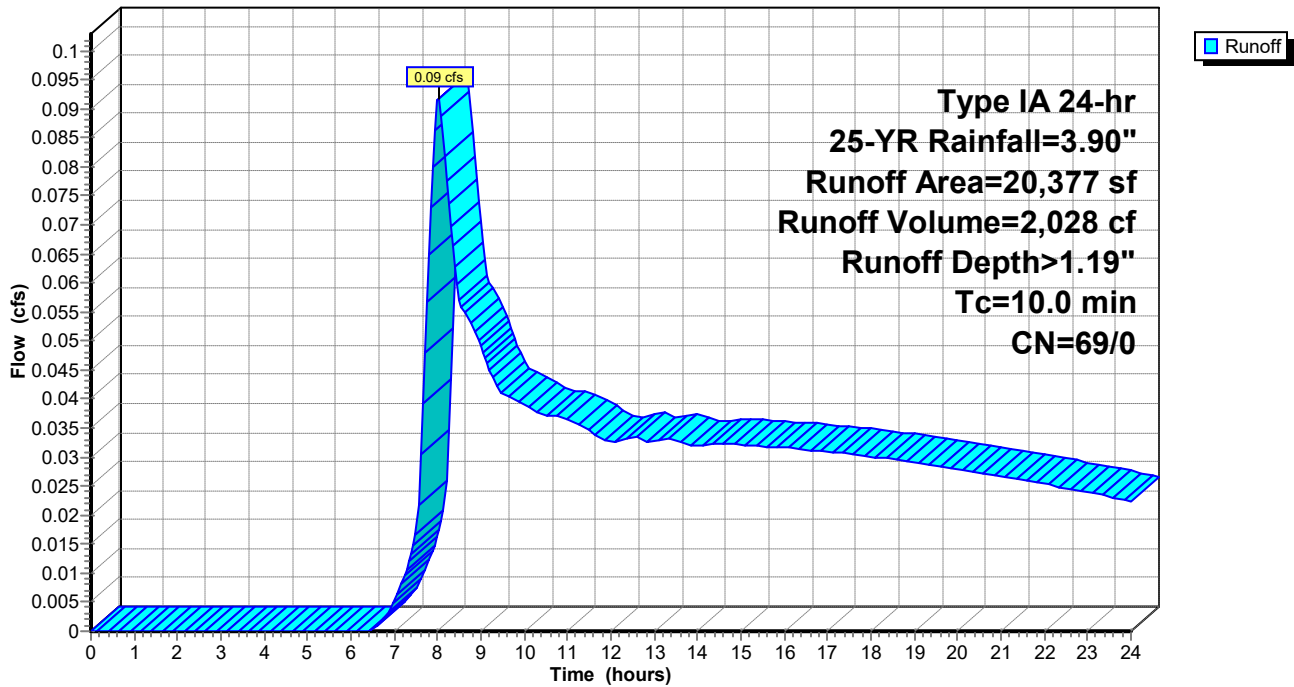

9656 Prelim Post-Developed

Type IA 24-hr 25-YR Rainfall=3.90"

Prepared by AKS Engineering & Forestry, LLC

Printed 7/28/2023

HydroCAD® 10.00-22 s/n 01338 © 2018 HydroCAD Software Solutions LLC

Summary for Pond 1S-2P: Stormwater Facility

Inflow Area = 37,602 sf, 84.02% Impervious, Inflow Depth > 3.39" for 25-YR event
 Inflow = 0.73 cfs @ 7.91 hrs, Volume= 10,613 cf
 Outflow = 0.31 cfs @ 8.42 hrs, Volume= 8,295 cf, Atten= 57%, Lag= 30.9 min
 Primary = 0.31 cfs @ 8.42 hrs, Volume= 8,295 cf

Routing by Dyn-Stor-Ind method, Time Span= 0.00-24.00 hrs, dt= 0.05 hrs
 Peak Elev= 172.48' @ 8.42 hrs Surf.Area= 1,950 sf Storage= 3,601 cf

Plug-Flow detention time= 318.3 min calculated for 8,295 cf (78% of inflow)
 Center-of-Mass det. time= 175.0 min (847.8 - 672.9)

Volume	Invert	Avail.Storage	Storage Description	
#1	169.50'	5,893 cf	Custom Stage Data (Prismatic) Listed below (Recalc)	
Elevation (feet)	Surf.Area (sq-ft)	Voids (%)	Inc.Store (cubic-feet)	Cum.Store (cubic-feet)
169.50	550	0.0	0	0
170.50	955	100.0	753	753
171.50	1,430	100.0	1,193	1,945
172.50	1,960	100.0	1,695	3,640
173.50	2,545	100.0	2,253	5,893

Device	Routing	Invert	Outlet Devices
#1	Primary	169.30'	12.0" Round Culvert L= 65.0' Ke= 0.620 Inlet / Outlet Invert= 169.30' / 169.00' S= 0.0046 '/' Cc= 0.900 n= 0.013, Flow Area= 0.79 sf
#2	Device 1	169.50'	0.5" Vert. Orifice/Grate C= 0.620
#3	Device 1	171.50'	2.5" Vert. Detention Orifice C= 0.620
#4	Primary	172.40'	2.2' long (Profile 17) Broad-Crested Rectangular Weir Head (feet) 0.49 0.98 1.48 1.97 2.46 2.95 Coef. (English) 2.84 3.13 3.26 3.30 3.31 3.31

Primary OutFlow Max=0.31 cfs @ 8.42 hrs HW=172.48' TW=0.00' (Dynamic Tailwater)

- 1=Culvert (Passes 0.17 cfs of 5.19 cfs potential flow)
- 2=Orifice/Grate (Orifice Controls 0.01 cfs @ 8.56 fps)
- 3=Detention Orifice (Orifice Controls 0.16 cfs @ 4.66 fps)
- 4=Broad-Crested Rectangular Weir (Weir Controls 0.14 cfs @ 0.80 fps)

Pond 1S-2P: Stormwater Facility

Hydrograph

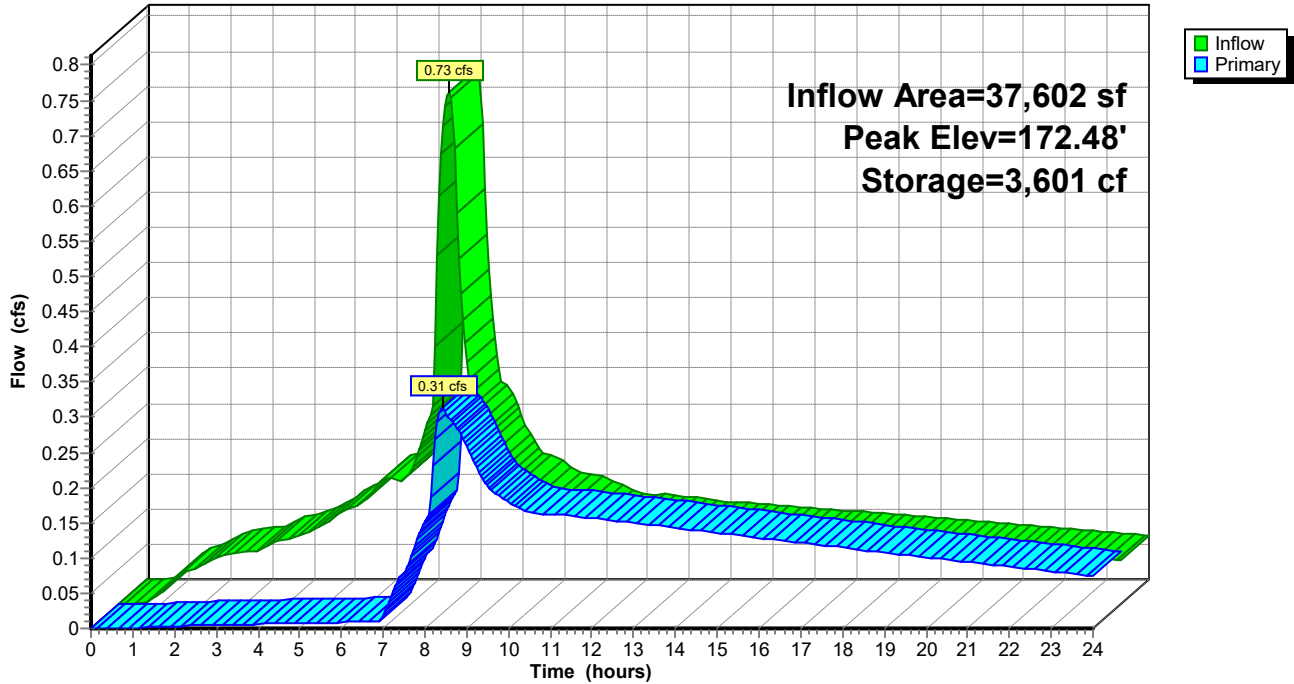

9656 Prelim Post-Developed

Type IA 24-hr 25-YR Rainfall=3.90"

Prepared by AKS Engineering & Forestry, LLC

Printed 7/28/2023

HydroCAD® 10.00-22 s/n 01338 © 2018 HydroCAD Software Solutions LLC

Summary for Pond UD: Pipe Storage

Inflow Area = 44,783 sf, 83.50% Impervious, Inflow Depth > 3.38" for 25-YR event
 Inflow = 0.86 cfs @ 7.91 hrs, Volume= 12,606 cf
 Outflow = 0.65 cfs @ 8.11 hrs, Volume= 9,194 cf, Atten= 24%, Lag= 12.3 min
 Primary = 0.65 cfs @ 8.11 hrs, Volume= 9,194 cf

Routing by Dyn-Stor-Ind method, Time Span= 0.00-24.00 hrs, dt= 0.05 hrs
 Peak Elev= 171.78' @ 8.11 hrs Surf.Area= 674 sf Storage= 3,882 cf

Plug-Flow detention time= 305.2 min calculated for 9,174 cf (73% of inflow)
 Center-of-Mass det. time= 134.0 min (807.4 - 673.3)

Volume	Invert	Avail.Storage	Storage Description
#1	168.00'	4,021 cf	48.0" Round CMP_Round 48" x 2 L= 160.0' S= 0.0010 '/

Device	Routing	Invert	Outlet Devices
#1	Primary	168.00'	12.0" Round Culvert L= 80.0' Ke= 0.600 Inlet / Outlet Invert= 168.00' / 166.18' S= 0.0227 '/ Cc= 0.900 n= 0.013, Flow Area= 0.79 sf
#2	Device 1	168.00'	0.5" Horiz. Orifice/Grate C= 0.620 Limited to weir flow at low heads
#3	Device 1	171.10'	6.0" Vert. Orifice/Grate C= 0.620
#4	Device 1	172.00'	12.0" Horiz. Orifice/Grate C= 0.620 Limited to weir flow at low heads

Primary OutFlow Max=0.65 cfs @ 8.11 hrs HW=171.78' TW=0.00' (Dynamic Tailwater)

- 1=Culvert (Passes 0.65 cfs of 6.42 cfs potential flow)
- 2=Orifice/Grate (Orifice Controls 0.01 cfs @ 9.67 fps)
- 3=Orifice/Grate (Orifice Controls 0.64 cfs @ 3.25 fps)
- 4=Orifice/Grate (Controls 0.00 cfs)

Pond UD: Pipe Storage

Hydrograph

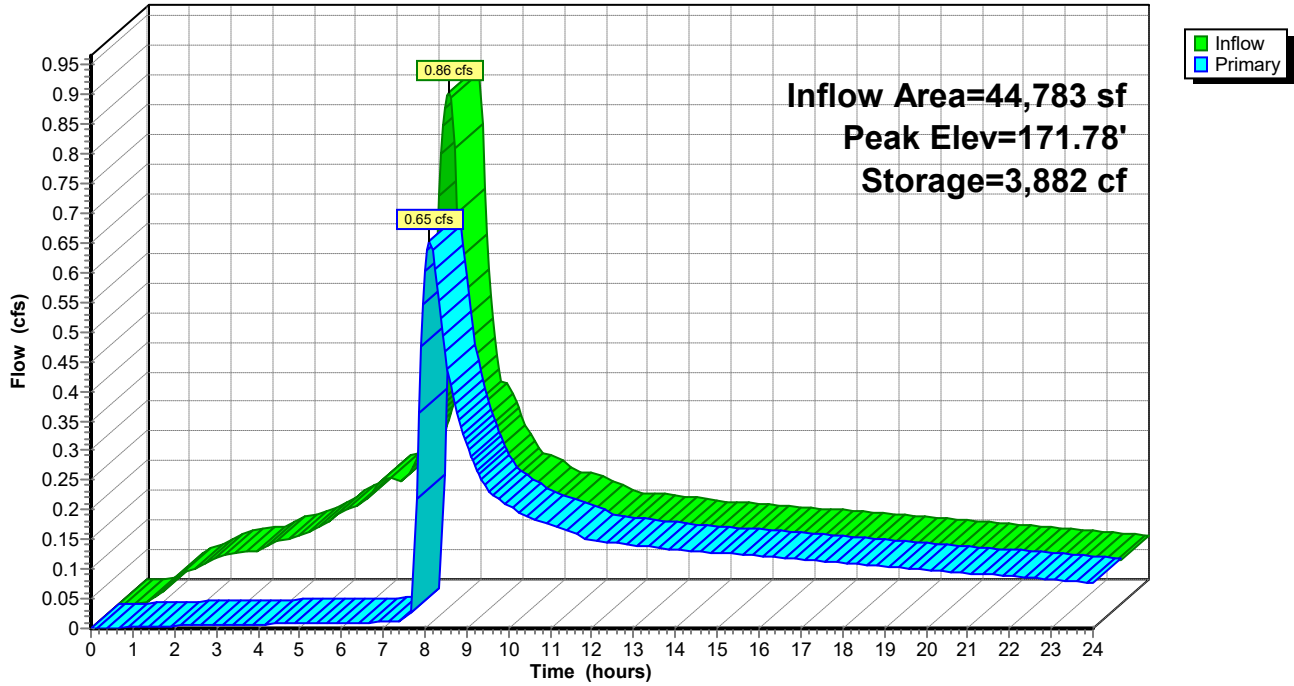

9656 Prelim Post-Developed

Prepared by AKS Engineering & Forestry, LLC

HydroCAD® 10.00-22 s/n 01338 © 2018 HydroCAD Software Solutions LLC

Type IA 24-hr 25-YR Rainfall=3.90"

Printed 7/28/2023

Summary for Link Post: Total

Inflow Area = 102,762 sf, 67.14% Impervious, Inflow Depth > 2.28" for 25-YR event
Inflow = 0.95 cfs @ 8.26 hrs, Volume= 19,517 cf
Primary = 0.95 cfs @ 8.26 hrs, Volume= 19,517 cf, Atten= 0%, Lag= 0.0 min

Primary outflow = Inflow, Time Span= 0.00-24.00 hrs, dt= 0.05 hrs

Link Post: Total

Hydrograph

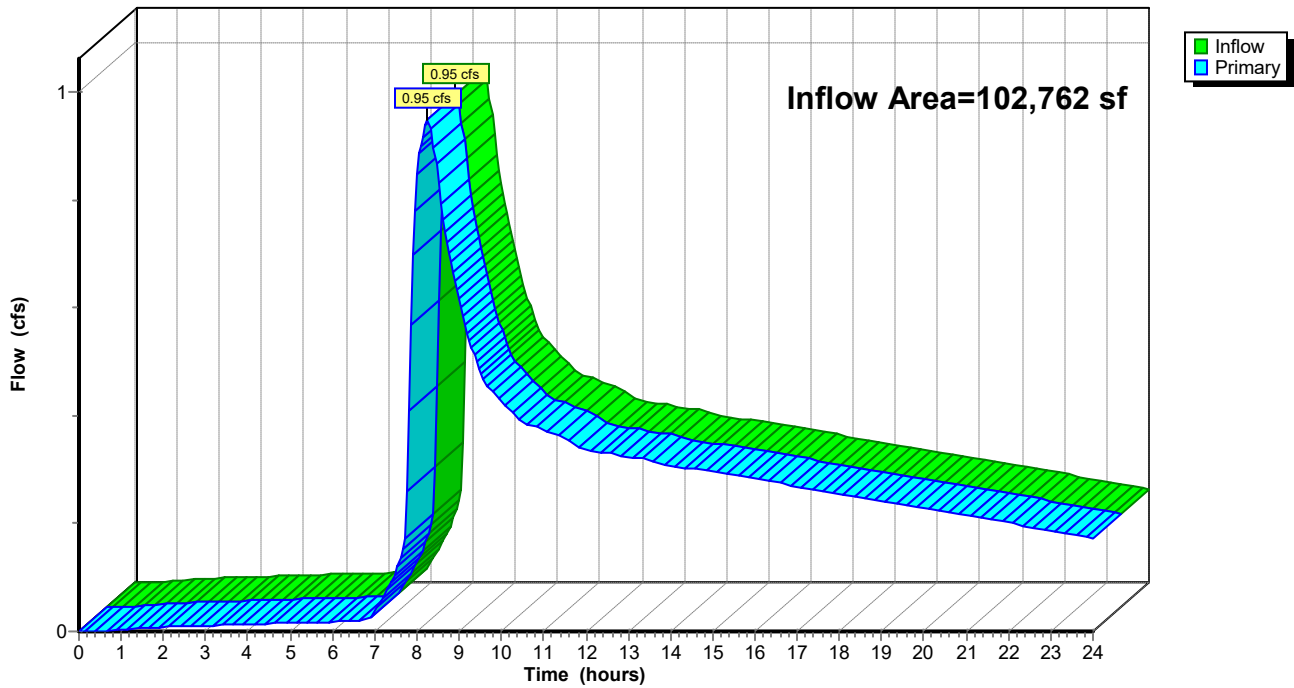

Appendix C: Stormwater Quality Calculations



STORMWATER QUALITY CALCULATIONS

Project: Cornelius South
AKS Job No.: 9656
Date: 7/19/2023
Done By: JG
Checked By: CMS

IMPERVIOUS AREA

Total Site Area: 0.86 acres
Total Site Area: 37,602 square feet (sf)
Number of Lots: 1
Impervious Area Per Lot: 31,594 sf

Total Impervious Lot Area: 31,594 sf
Road & Sidewalk Impervious Area: 0 sf

Total Impervious Area: 31,594 sf

WATER DESIGN QUALITY VOLUME (WQV)

(Per CWS 4.08.5a2 - R&O 19-05)

$$WQV = \frac{0.36" \times \text{Area (ft)}}{12" \text{ per ft}} = 948 \text{ cubic feet}$$

WATER QUALITY FLOW (WQF)

(Per CWS 4.08.5a3 - R&O 19-05)

$$WQF = \frac{WQV \text{ (sf)}}{4 \times 60 \times 60} = 0.066 \text{ cfs}$$

WATER QUALITY MANHOLE SUMP VOLUME CALCULATIONS

(Per CWS 4.09.1 - R&O 19-05)

CWS Criteria: Sump Volume = 20 cubic feet per 1.0 cfs of flow

25-year Flow through WQ Manhole 1S-1.1 = **0.86** cfs
Calculated Manhole Sump Volume = **17.2** cubic feet
Calculated Manhole Sump Depth (60" Dia. Manhole) = **0.9** ft < 5 feet maximum

EXTENDED DRY BASIN DESIGN & CALCULATIONS

Hydraulic Design Criteria (Per CWS 4.09.5a/b/c - R&O 19-05)

Permanent Pool Depth: 0.2 ft
 Permanent Pool covers bottom of basin
 Design Detention Volume: 1.0 x Water Quality Volume (WQV)
 Water Quality Drawdown Time: 48 hours
 Maximum Depth of WQ Pool: 5 ft
 Avoid direct flow across WQ pond to avoid short circuiting

Extended Dry Basin Sizing Design:

Bottom Slope (ft/ft)	Minimum Bottom Width (ft)	Side Slopes H:V	Top of Pond Elev. (ft)	Perm. Pool Depth (ft)	Pool Bottom Area (sf)	Bottom of Pool Elev. (ft)
0.0	8	3.0	173.50	0.2	546	169.5

Water Quality Flow Hydraulic Calculations:

Q (cfs)	Pool Elev. at WQV (ft)	Orifice CL Elevation (ft)	Calculated Orifice Diameter (in)	Max. Pool Elev., 25-yr Event (ft)	Calculated Pond WQV (cubic feet)	Calculated WQV Pool Depth (ft)
0.01	171.0	169.52	0.46	172.50	1232	1.4

Check Against Design Criteria:

	Calculated		Meet CWS Criteria?		
Minimum Freeboard:	1.0	feet	Yes	more than	1 foot
Minimum Bottom Width:	8	feet	Yes	greater than	4 feet
Maximum Pool Depth at WQV:	1.4	feet	Yes	less than	5 feet
Detained Water Quality Volume:	1232	cubic feet	Yes	greater than	948 cf

Appendix D: USDA-NRCS Soil Resource Report

Custom Soil Resource Report
Map—Hydrologic Soil Group (9656)

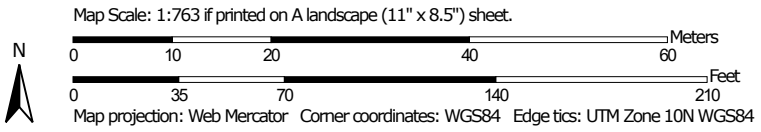
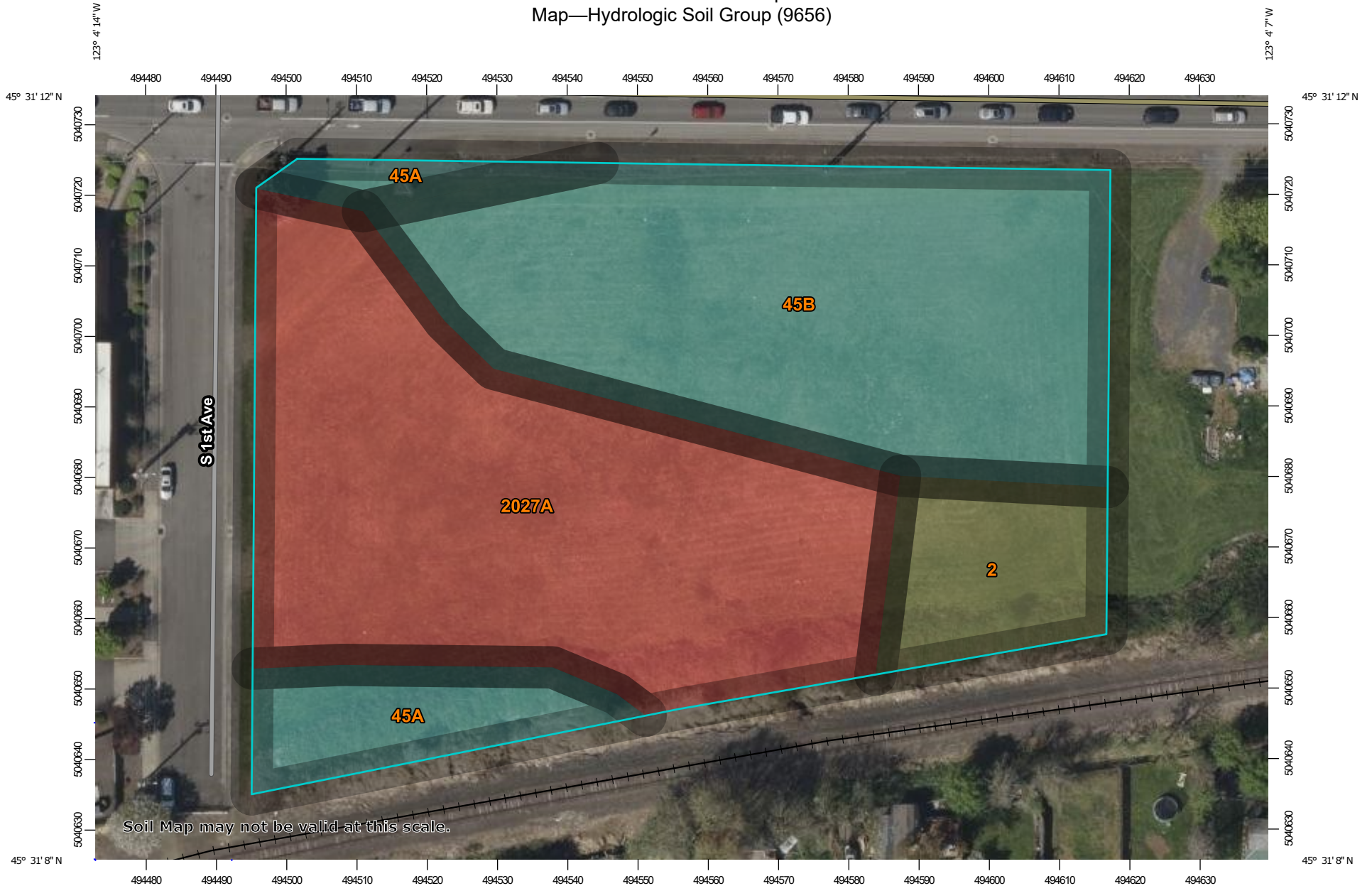

MAP LEGEND

Area of Interest (AOI)









 Area of Interest (AOI)

Soils

Soil Rating Polygons





-  A
-  A/D
-  B
-  B/D
-  C
-  C/D
-  D
-  Not rated or not available

Soil Rating Lines

-  A
-  A/D
-  B
-  B/D
-  C
-  C/D
-  D
-  Not rated or not available

Soil Rating Points





-  A
-  A/D
-  B
-  B/D

-  C
-  C/D
-  D
-  Not rated or not available

Water Features

 Streams and Canals

Transportation

-  Rails
-  Interstate Highways
-  US Routes
-  Major Roads
-  Local Roads

Background

 Aerial Photography

MAP INFORMATION

The soil surveys that comprise your AOI were mapped at 1:20,000.

Warning: Soil Map may not be valid at this scale.

Enlargement of maps beyond the scale of mapping can cause misunderstanding of the detail of mapping and accuracy of soil line placement. The maps do not show the small areas of contrasting soils that could have been shown at a more detailed scale.

Please rely on the bar scale on each map sheet for map measurements.

Source of Map: Natural Resources Conservation Service
 Web Soil Survey URL:
 Coordinate System: Web Mercator (EPSG:3857)

Maps from the Web Soil Survey are based on the Web Mercator projection, which preserves direction and shape but distorts distance and area. A projection that preserves area, such as the Albers equal-area conic projection, should be used if more accurate calculations of distance or area are required.

This product is generated from the USDA-NRCS certified data as of the version date(s) listed below.

Soil Survey Area: Washington County, Oregon
 Survey Area Data: Version 22, Sep 14, 2022

Soil map units are labeled (as space allows) for map scales 1:50,000 or larger.

Date(s) aerial images were photographed: Apr 16, 2021—Apr 18, 2021

The orthophoto or other base map on which the soil lines were compiled and digitized probably differs from the background imagery displayed on these maps. As a result, some minor shifting of map unit boundaries may be evident.

Table—Hydrologic Soil Group (9656)

Map unit symbol	Map unit name	Rating	Acres in AOI	Percent of AOI
2	Amity silt loam	C/D	0.2	8.1%
45A	Woodburn silt loam, 0 to 3 percent slopes	C	0.2	9.1%
45B	Woodburn silt loam, 3 to 7 percent slopes	C	0.9	39.0%
2027A	Verboort silty clay loam, 0 to 3 percent slopes	D	1.0	43.8%
Totals for Area of Interest			2.3	100.0%

Rating Options—Hydrologic Soil Group (9656)

Aggregation Method: Dominant Condition

Component Percent Cutoff: None Specified

Tie-break Rule: Higher

Appendix E: TR55 Runoff Curve Numbers

Table 2-2a Runoff curve numbers for urban areas^{1/}

Cover description Cover type and hydrologic condition	Average percent impervious area ^{2/}	Curve numbers for hydrologic soil group			
		A	B	C	D
<i>Fully developed urban areas (vegetation established)</i>					
Open space (lawns, parks, golf courses, cemeteries, etc.) ^{3/} :					
Poor condition (grass cover < 50%)		68	79	86	89
Fair condition (grass cover 50% to 75%)		49	69	79	84
Good condition (grass cover > 75%)		39	61	74	80
Impervious areas:					
Paved parking lots, roofs, driveways, etc. (excluding right-of-way)		98	98	98	98
Streets and roads:					
Paved; curbs and storm sewers (excluding right-of-way)		98	98	98	98
Paved; open ditches (including right-of-way)		83	89	92	93
Gravel (including right-of-way)		76	85	89	91
Dirt (including right-of-way)		72	82	87	89
Western desert urban areas:					
Natural desert landscaping (pervious areas only) ^{4/}		63	77	85	88
Artificial desert landscaping (impervious weed barrier, desert shrub with 1- to 2-inch sand or gravel mulch and basin borders)		96	96	96	96
Urban districts:					
Commercial and business	85	89	92	94	95
Industrial	72	81	88	91	93
Residential districts by average lot size:					
1/8 acre or less (town houses)	65	77	85	90	92
1/4 acre	38	61	75	83	87
1/3 acre	30	57	72	81	86
1/2 acre	25	54	70	80	85
1 acre	20	51	68	79	84
2 acres	12	46	65	77	82
<i>Developing urban areas</i>					
Newly graded areas (pervious areas only, no vegetation) ^{5/}					
		77	86	91	94
Idlelands (CN's are determined using cover types similar to those in table 2-2c).					

¹ Average runoff condition, and $I_a = 0.2S$.

² The average percent impervious area shown was used to develop the composite CN's. Other assumptions are as follows: impervious areas are directly connected to the drainage system, impervious areas have a CN of 98, and pervious areas are considered equivalent to open space in good hydrologic condition. CN's for other combinations of conditions may be computed using figure 2-3 or 2-4.

³ CN's shown are equivalent to those of pasture. Composite CN's may be computed for other combinations of open space cover type.

⁴ Composite CN's for natural desert landscaping should be computed using figures 2-3 or 2-4 based on the impervious area percentage (CN=98) and the pervious area CN. The pervious area CN's are assumed equivalent to desert shrub in poor hydrologic condition.

⁵ Composite CN's to use for the design of temporary measures during grading and construction should be computed using figure 2-3 or 2-4 based on the degree of development (impervious area percentage) and the CN's for the newly graded pervious areas.

Table 2-2b Runoff curve numbers for cultivated agricultural lands ^{1/}

Cover description			Curve numbers for hydrologic soil group			
Cover type	Treatment ^{2/}	Hydrologic condition ^{3/}	A	B	C	D
Fallow	Bare soil	—	77	86	91	94
	Crop residue cover (CR)	Poor	76	85	90	93
		Good	74	83	88	90
Row crops	Straight row (SR)	Poor	72	81	88	91
		Good	67	78	85	89
	SR + CR	Poor	71	80	87	90
		Good	64	75	82	85
	Contoured (C)	Poor	70	79	84	88
		Good	65	75	82	86
	C + CR	Poor	69	78	83	87
		Good	64	74	81	85
	Contoured & terraced (C&T)	Poor	66	74	80	82
		Good	62	71	78	81
C&T+ CR	Poor	65	73	79	81	
	Good	61	70	77	80	
Small grain	SR	Poor	65	76	84	88
		Good	63	75	83	87
	SR + CR	Poor	64	75	83	86
		Good	60	72	80	84
	C	Poor	63	74	82	85
		Good	61	73	81	84
	C + CR	Poor	62	73	81	84
		Good	60	72	80	83
	C&T	Poor	61	72	79	82
		Good	59	70	78	81
C&T+ CR	Poor	60	71	78	81	
	Good	58	69	77	80	
Close-seeded or broadcast legumes or rotation meadow	SR	Poor	66	77	85	89
		Good	58	72	81	85
	C	Poor	64	75	83	85
		Good	55	69	78	83
	C&T	Poor	63	73	80	83
Good	51	67	76	80		

¹ Average runoff condition, and $I_a=0.2S$

² Crop residue cover applies only if residue is on at least 5% of the surface throughout the year.

³ Hydraulic condition is based on combination factors that affect infiltration and runoff, including (a) density and canopy of vegetative areas, (b) amount of year-round cover, (c) amount of grass or close-seeded legumes, (d) percent of residue cover on the land surface (good $\geq 20\%$), and (e) degree of surface roughness.

Poor: Factors impair infiltration and tend to increase runoff.

Good: Factors encourage average and better than average infiltration and tend to decrease runoff.

Table 2-2c Runoff curve numbers for other agricultural lands ^{1/}

Cover description Cover type	Hydrologic condition	Curve numbers for hydrologic soil group			
		A	B	C	D
Pasture, grassland, or range—continuous forage for grazing ^{2/}	Poor	68	79	86	89
	Fair	49	69	79	84
	Good	39	61	74	80
Meadow—continuous grass, protected from grazing and generally mowed for hay.	—	30	58	71	78
Brush—brush-weed-grass mixture with brush the major element ^{3/}	Poor	48	67	77	83
	Fair	35	56	70	77
	Good	30 ^{4/}	48	65	73
Woods—grass combination (orchard or tree farm) ^{5/}	Poor	57	73	82	86
	Fair	43	65	76	82
	Good	32	58	72	79
Woods. ^{6/}	Poor	45	66	77	83
	Fair	36	60	73	79
	Good	30 ^{4/}	55	70	77
Farmsteads—buildings, lanes, driveways, and surrounding lots.	—	59	74	82	86

¹ Average runoff condition, and $I_a = 0.2S$.

² *Poor*: <50% ground cover or heavily grazed with no mulch.

Fair: 50 to 75% ground cover and not heavily grazed.

Good: > 75% ground cover and lightly or only occasionally grazed.

³ *Poor*: <50% ground cover.

Fair: 50 to 75% ground cover.

Good: >75% ground cover.

⁴ Actual curve number is less than 30; use CN = 30 for runoff computations.

⁵ CN's shown were computed for areas with 50% woods and 50% grass (pasture) cover. Other combinations of conditions may be computed from the CN's for woods and pasture.

⁶ *Poor*: Forest litter, small trees, and brush are destroyed by heavy grazing or regular burning.

Fair: Woods are grazed but not burned, and some forest litter covers the soil.

Good: Woods are protected from grazing, and litter and brush adequately cover the soil.

Table 2-2d Runoff curve numbers for arid and semiarid rangelands ^{1/}

Cover description Cover type	Hydrologic condition ^{2/}	Curve numbers for hydrologic soil group			
		A ^{3/}	B	C	D
Herbaceous—mixture of grass, weeds, and low-growing brush, with brush the minor element.	Poor		80	87	93
	Fair		71	81	89
	Good		62	74	85
Oak-aspen—mountain brush mixture of oak brush, aspen, mountain mahogany, bitter brush, maple, and other brush.	Poor		66	74	79
	Fair		48	57	63
	Good		30	41	48
Pinyon-juniper—pinyon, juniper, or both; grass understory.	Poor		75	85	89
	Fair		58	73	80
	Good		41	61	71
Sagebrush with grass understory.	Poor		67	80	85
	Fair		51	63	70
	Good		35	47	55
Desert shrub—major plants include saltbush, greasewood, creosotebush, blackbrush, bursage, palo verde, mesquite, and cactus.	Poor	63	77	85	88
	Fair	55	72	81	86
	Good	49	68	79	84

¹ Average runoff condition, and $I_a = 0.2S$. For range in humid regions, use table 2-2c.

² Poor: <30% ground cover (litter, grass, and brush overstory).

Fair: 30 to 70% ground cover.

Good: > 70% ground cover.

³ Curve numbers for group A have been developed only for desert shrub.

Exhibit G: Notes from Pre-Application Conference (PAC-16-22)



**PRE-APPLICATION CONFERENCE
PAC-16-22**

Tuesday, October 25, 2022
Community Development Department
1300 S Kodiak Circle
Cornelius, OR 97113

Land Use Notes

Applicant: Melissa Slotemaker
AKE Engineering & Forestry
12965 SW Herman Road, Suite 100
Tualatin, OR 97062

Site of Interest: SE Corner of S 1st Street and Baseline Street

Map and Tax lot: 1S34BB300

Applicants in Attendance: Darko Simic, AKS Engineering; Sean Vermilya, AKS Engineering; Melissa Slotemaker, AKS Land Use Planner; Cody Street, AKS Engineering; Ethan Donovan; Gene Belonky, Studio 3 Architect; Ethan Donovan, AKS Engineer; Nathan, future developer.

Staff in Attendance: Tim Franz, Senior Planner; Susan Rush, Permit Specialist; Peter Brandom, City Manager; Mark Crowell, Public Works Director; Richard Mead, Building Official; David Nemeyer, Fire Marshall; Terry Keyes, City Engineer; Kevin Oppenlander, Project Manager; Yvette Hamilton, Building Inspector; Bob Ray, Chief of Police;

Other Agency Staff in Attendance: Tony Rikli, ODOT Region Access Management Engineer ; Marah Danielson, ODOT Region 1 Development Review Manager;

Address of site under Consideration: The site is currently undeveloped and it is at the SE corner S 1st Avenue and Baseline Street, Cornelius, OR 97113. The subject site one tax lot, totaling approximately 2.32 acres in size. The property is located within the Highway Commercial, C-2 zoning district of the City of Cornelius.

Proposal: The applicant is proposing to develop the site with a multi-building retail/office complex including a tenant space with a drive-thru window.

Land Use Requirements:

This land use summary is comprised of the guidance provided at the 10/25/22 pre-application conference and follow up discussions. The necessary application is:

- 1) Type III Site Design Review. This is a technical review of the proposed on-site improvements by the Planning Commission.

If an uncovered outdoor seating area is proposed or other uses that require Conditional Use Permit approval, then an additional review/permit will also be required. If required, the Type III Site Design Review and a Type II or III Conditional Use Permit can be reviewed concurrently.

For a Type III Site Design Review: Generally, to process a Type III Site Design Review, the applicant should anticipate an 8 to 10-week timeframe from receipt of a complete application to a decision by the Planning Commission.

All applications that are reviewed at a public hearing require a neighborhood meeting to be held by the applicant. Notices for the neighborhood meeting must be sent out no less than 20 days prior to the scheduled neighborhood meeting. Notice to property owners within 250 feet of the subject site is required. A title company can assist you with obtaining a mailing list for your notice to be sent out; a copy of the notice shall also be sent to the Community Development Department staff. Information regarding the noticing requirements is attached. Please note that neighborhood meetings are only valid for a period of 180 days. A meeting must be in an ADA assessable location within Cornelius. We will also require a notarized affidavit of the mailing list and neighborhood meeting announcement, a list of attendees, and minutes from your neighborhood meeting to be submitted in your land use application packet.

Application Review: Staff will review an application for completeness within thirty (30) days of receipt. The applicant will be notified in writing on the status of completeness. An application must be deemed complete by the 10th of the month in order to be scheduled for the following month's Planning Commission meeting (e.g., May 10th for a June hearing). If the application is deemed complete the City will begin to process the application, including the required public notice. Staff will review the application materials and prepare a staff report with a recommendation to the Planning Commission. The staff report will be complete and available one week prior to the Planning Commission hearing. The Planning Commission meets the fourth Tuesday of each month.

Staff recommends that an application should be submitted for completeness review a minimum of 15 to 20 days prior to the 10th of the target month. This will allow staff adequate time to review your application and, if needed, it provides you time to respond to any staff requests for additional application materials.

- The current application fee for a Type III Site Design Review is \$3,569.00.

Please note that fee generally increase on the 1st of each July.

Decision/Appeal: Once a decision is made, a Notice of Decision will be sent to the applicant. The Notice of Decision will identify the appeal period and options for appeal. Once the appeal period is over, you may proceed with complying with the conditions of approval.

Please note that the City of Cornelius is currently contracting building services, review, and inspections with the City of Forest Grove Building Division. The land use application(s) described above must be completed and approved prior to submittal of any applications to the Forest Grove Building Division that may be required.

Land Use Project Specific Information: Based on the information provided during the pre-application conference, here are comments/concerns that were generally discussed. There may be other unforeseen issues/concerns that cannot be addressed until an application packet is submitted to the city for review and consideration.

- Development and use of the site will need to comply with Title 18 of the City of Cornelius Development Code. This includes, but is not limited to, demonstrating compliance to Chapters 18.45 Highway Commercial, C-2; 18.100 Site Design Review, 18.105 Conditional Use Permit (if applicable); 18.143 Transportation Facilities, 18.145 Off-Street Parking and Loading; 18.150 Special Use Regulations; and 18.155 Solar Access for New Development.
- The site has a known wetland area upon it. A wetland delineation and report will be necessary. Please include them with your application submittal. packet.
- An ODOT letter of response for the proposed development will be necessary with your land use application submittal.
- All utilities will be required to be underground.
- No additional right-of-ways along Baseline Street or S 1st Avenue are anticipated.
- All signage shall comply with the Sign Code.
- A screened trash enclosure will be required. Please provide a detail of the screened trash enclosure within your application packet. Due to the nature of the proposed drive-thru for a coffee shop or another café/restaurant use, the trash enclosure will be required to be covered with a grease interceptor.
- On the site plan, please note where cross-over access easements. Please provide copies of all easements for review, as access to and from the site will be primarily from easements.
- A Service Provider Letter from Clean Water Services (CWS) is required.

- All on-site stormwater facilities must be proposed and built to CWS standards. A stormwater report is necessary, which will be reviewed by the City Engineer. The stormwater report and proposed stormwater facilities must be included within your land use application packet.
- Proposed on-site lighting will be required not to shine or glare onto abutting properties or within the abutting ROW's. A photometric study and sheet with lighting details will be required. Please provide details of the on-site lighting to be installed.
- Provide pedestrian connectivity from Baseline Street and S 1st Avenue to the new buildings.
- All landscaping will be required to have an irrigation system installed. Please provide a detailed landscaping plan with provisions for irrigation. The landscaping plan will also need to identify the types of proposed vegetation, trees, materials and their respective location.
- All vehicle maneuvering areas are to be of an approved impervious (concrete or asphalt) surface.
- For the drive-up window the CMC requires a minimum vehicle reservoir of 10-spaces. Please demonstrate compliance on the submitted site plan.
- Please provide a materials/color board of the proposed new building. A color printout on paper is acceptable.
- Please provide elevations of the proposed building.
- Please provide details of the required bicycle parking racks.
- Any future water meters will need to be within the ROW, not inside of private property.
- On the submitted site plan please demonstrate compliance with Chapter 18.150.070 (Clear Vision Areas) at the driveways.
- Provide on the site plan, vehicle directional arrows and striped pedestrian crossing areas.
- If on-site directional signage is proposed, please include their details and locations for review. Please also include details/elevations of the proposed drive-up menu board/structure.
- The proposed parking lot plan must conform to the parking code standards. Please provide a detailed parking space analysis.

- Abutting property owners, where improvement are proposed within the easement areas need to sign the land use application, as such proposed improvements will be upon their property. For information of their proposal and approved site plan, please visit the City website at the following link: <https://www.ci.cornelius.or.us/cdp/project/kem-sports-courts>

Engineering: Terry Keyes, P.E., City Engineer has prepared written comments concerning development of the site. Attached are his comments dated October 25, 2022.

Fire: Dave Nemeyer, Fire Marshal was in attendance, and he did not indicate concerns with the proposed layout of the site. As part of his review, he will want to look at the location of fire hydrants around the site.

Building: Building Official Rich Mead stated that the project appeared feasible. A Geotech report will be necessary with the development permit submittal. The project will need to comply with all applicable ADA requirements, as well as all applicable State Building Code requirements. Building Permit submittals (except electrical which is issued through Washington County) are applied for and reviewed through the City of Forest Grove Building Division. The Forest Grove Building Department Main Phone Line is 503-992-3229. Building Official Rich Mead can be reached by email at rmead@forestgrove-or.gov

A Commercial & Industrial Fee Estimate Work Sheet is also attached for your use to estimate System Development Charge (SDC) fees. If you have questions about SDC fees, please contact Susan Rush, Permit Technician at (503) 357-3011.

Oregon Department of Transportation: Baseline Street is an ODOT facility which is commonly known as State Highway 8. Access and ROW development permits are necessary from ODOT for establishing/improving access and ROW improvements along Baseline Street. As part of an application packet to the City, a current ODOT scoping letter will be necessary.

Other: There is a Washington County Transportation Development Tax (TDT). The TDT is a County-wide voter approved tax that the City administers within its limits. When development within the County occurs, the TDT must be assessed. To learn more about the TDT, we recommend that you review the Washington County TDT information page at:

<https://www.co.washington.or.us/LUT/Divisions/LongRangePlanning/PlanningPrograms/TransportationPlanning/transportation-development-tax.cfm>

The TDT is due at the time of issuance of a Building Permit. It may be deferred until issuance of an Occupancy Permit or it may be paid in installment payments with City approval. Historically, each July 1, the TDT has increased between 2% to 4%.

Based upon the current TDT rate schedule (7/1/22 – 6/30/23) for the proposed uses and size of buildings, the estimated TDT fee due is \$167,176. This estimate is based upon the Specialty Retail code 814, within the TDT rate schedule.

Thank you very much for taking the time to meet with us. If you have any further questions or if you need additional assistance with your application submittal process, please contact us at (503) 357-3011. We look forward to working with you to make your future development within the City of Cornelius a success.

Sincerely,

A handwritten signature in blue ink, appearing to read 'Tim Franz', with a long horizontal flourish extending to the right.

Tim Franz
Senior Planner



VIDEOCONFERENCE PRE-APPLICATION MEETING

PAC-16-22

Tuesday, October 25, 2022

Community Development Department

1300 S Kodiak Circle

Cornelius, OR 97113

MEETING MINUTES

Applicant: Melissa Slotemaker
AKE Engineering & Forestry
12965 SW Herman Road, Suite 100
Tualatin, OR 97062

Site of Interest: SE Corner of S 1st Street and Baseline Street

Map and Tax lot: 1S34BB300

Applicants in Attendance: Darko Simic, AKS Engineering; Sean Vermilya, AKS Engineering; Melissa Slotemaker, AKS Land Use Planner; Cody Street, AKS Engineering; Ethan Donovan; Gene Belonky, Studio 3 Architect; Ethan Donovan, AKS Engineer; Nathan, future developer.

Staff in Attendance: Tim Franz, Senior Planner; Susan Rush, Permit Specialist; Peter Brandom, City Manager; Mark Crowell, Public Works Director; Richard Mead, Building Official; David Nemeyer, Fire Marshall; Terry Keyes, City Engineer; Kevin Oppenlander, Project Manager; Yvette Hamilton, Building Inspector; Bob Ray, Chief of Police;

Other Agency Staff in Attendance: Tony Rikli, ODOT Region Access Management Engineer ; Marah Danielson, ODOT Region 1 Development Review Manager;

Senior Planner, Tim Franz, began the meeting by committing to supply notes and minutes from the meeting to the applicant within two to three weeks. After introductions, Mr. Franz invited the applicants to provide a brief summary of their proposal.

Darko Simic described the project, which consists of a vacant lot, approximately 2.3 acres, located on 1st Avenue and Baseline (Hwy 8). The property is Zoned C-2. The plan for the site is to develop a general retail (mixed with office space and retail,) maybe a drive-thru. The property is flat. The west-side, along 1st Avenue, is primarily all improved with sidewalk on both sides. There are existing drive-way drops for the property. On the north side, along Baseline, there is a bus stop along with a roadside ditch. To the south of the project is the Pacific Railroad. For this project, the railroad will not be touched. There is existing water, storm, and sewer to serve the property. He is unsure of any capacity issues or how the public systems works for the property. The current site plan is for a mixed retail use and includes parking and the main access from 1st Avenue.

Currently, the plan proposes access from Baseline as one way, right-in right-out. That can serve as dual access for emergency services.

Senior Planner Tim Franz discussed the site and city standards. The property is zoned Highway Commercial (C-2). The uses the applicant has proposed are permitted outright for that zone. There are no Land Use issues with compatibility and a Conditional Use Permit is not needed. To develop the property, the applicant will need to complete a Type III Site Design Review Application. It is a technical review of the proposed development of the site, to ensure it complies with all the standards of the zoning and all the technical review standards of the city code. It requires a public hearing before the Planning Commission. Mr. Franz explained the process and the requirements for a formal Neighborhood Meeting. He explained the timeline for submitting an application and having a Public Hearing with the Planning Commission. He recommends the applicant make one copy of their application and share it with the Community Development Department, so that it can be reviewed for completeness before submittal to the Planning Commission. He explained that his comments are based on the current proposed development and the requirements could change if the applicant changes their proposal. The current application fee for a Type III Site Design Review is \$3,569.00.

ODOT Region 1 Development Review Manager, Marah Danielson, explained the Oregon Department of Transportation (ODOT) recommendations for the proposed development. ODOT cannot require frontage improvements, but does strongly recommend the city require frontage improvements consistent with their Transportation System Plan. ODOT would ask for sidewalks along Baseline. ODOT is recommending wider bike lanes of 8ft, if they are not already meeting that standard. The city requires street trees and a planter strip for the site. For a highway with a speed limit of 40mph, ODOT cannot permit street trees between the sidewalk and the road, they can be placed on the other side of the sidewalk. If the city requires a right-of-way, it needs to be donated. The spacing standard for access is 400ft. The access is restricted to a right-in right-out. The proposal appears to meet that standard. For ODOT permits, the applicant will need a Statewide Highway Approach permit; the district 2B office will assign an Access Coordinator to the project. The Access Coordinator will do all the permitting related to the project, as well as process any right-of-way donations. That process can take three to six months. The right-of-way donation is donation property to ODOT. ODOT accepts donations in fees. The donation process takes about three months to complete. There are no fees associated with ODOT permits; however, if the development includes \$100,000 worth of frontage improvements on the state highway, ODOT can recoup the cost of the technical review fees. Those fees are calculated at the time the applicant applies for a permit.

Sean Vermilya asked for clarification on the 400ft spacing standards.

ODOT Region Access Management Engineer, Tony Rikli, explained the Access Spacing Standard. The Access Spacing Standard is 800ft, but with a one way right-in right-out the standard can be reduced to 400ft. The current proposal meets that 400ft standard, it also aligns with the property to the north. He asked if that was correct.

Mr. Vermilya responded that he doesn't know if they can meet the 400ft spacing and asked if the access can be used for emergencies.

Mr. Rikli answered that he believes they can meet the 400ft spacing standard with a little adjustment. For an emergency only access, ODOT requires a letter from the fire department stating they require an access at that point. For an emergency access, a locked gate with an emergency Knox Box will be required. The keys will only be provided to ODOT and the Fire Department.

Ms. Danielson noted that she will provide comments from ODOT to the applicant, within a couple of weeks. She is the applicant's contact with ODOT. If any questions or concerns come up, the applicants can reach out to her. She can coordinate with technical staff and schedule any necessary meetings. Cornelius asks that a letter from ODOT is included with any application, she can provide that letter. Ms. Danielson asked to be kept informed of any changes to the site plan. She explained the applicant can submit an application for a State Highway Approach Road Permit once a Land Use Application has been submitted to the City of Cornelius. ODOT can issue permits once the City has approved the Land Use Application. ODOT recommends the city not issue building permits until all permits from ODOT have been obtained.

City Engineer, Terry Keyes, discussed the city requirements for the proposed development. He explained street requirements along Baseline. Everything ODOT recommends, the city requires. This development will require a bike lane, concrete curb and gutter, planter strip, 6ft concrete sidewalk, and Cobra head streetlights on their own poles. The street trees will go behind the sidewalk. The right-of-way will not need to be expanded for the trees; if they don't fit in the existing right-of-way the applicants can do an easement. There are overhead utilities, PGE transmission lines and telecommunication lines. The transmission lines can stay overhead, but the others need to be put underground. The driveway will need to meet the Commercial Driveway Standard. There is a bus stop on the corner of 1st; no accommodation needs to be made for it except to ensure there is concrete where people exit the bus. He reiterated that ODOT requires permits for any work done in their right-of-way, including street trees. He explained street requirements along 1st Avenue. There are a couple existing drive-way drops. If the existing drive-way drops do not line up with the proposal, the applicants will have to replace them with sidewalk, curb, and gutter. The frontage improvements will also include street trees with a parkway strip. No street lights are required for 1st Avenue, and there are no overhead lines.

Mr. Keyes explained connecting to city utilities. There is an 8-inch water line that runs down Adair to Baseline, part of the way, to a fire hydrant. There is an undersized substandard 4-inch line that continues easterly. The applicants will have to continue the 8-inch water line to their eastern property line. The Fire Department will comment on fire hydrant requirements. There are a couple sanitary sewer lines near the property. The sanitary sewer line that goes down 1st Avenue, to a pump station near the railroad tracks, is at capacity. There is a 10-inch line going to the east, that goes all the way to 1st Avenue; that is the line he recommends connecting to. He explained the storm system. He recommends using the storm line on 1st Avenue that goes into a controlled manhole. He explained Clean Water Services' (CWS) requirements: water treatment and detention. The development must include a low impact development approach. For example a green roof, or planter boxes.

Mr. Keyes discussed the potential wetland on the southern end of the property. The property to the east is in the development process. They proceeded assuming there isn't a wetland. They are

in the process with DSL to determine if it is a wetland. If they are successful, this development will not have a wetland on the property. He predicts they will not be successful, in which case the applicant has plotted the safest approach. For erosion control, the applicants will do a 1200 CN Permit. He would like to work with the applicant through the development process.

Building Official, Richard Mead, discussed building requirements for the development. The applicants will need to have a Geotech Survey completed. Any findings that affect foundation design and drainage, needs to be incorporated into the structural design. The current site plan appears to have good circulation and he had no further concerns or comments at the time.

Mr. Simic asked if they need a Geotech Analysis for the Land Use/Design Review.

Mr. Franz answered that the Geotech is needed when the applicants apply for building permits.

Fire Marshal, David Neymeyer, discussed access and other requirements for emergency services. He does not believe there is a need for access on Baseline, the access on 1st is sufficient. The current hydrants are on Baseline; there are no hydrants on 1st Avenue. Use of the fire hydrants for the site would require running hose across Baseline.

Mr. Keyes recommended, when the applicants extend the 8-inch water line to the east, they bring a 6-inch line across and put a fire hydrant on the south side of Baseline.

Mr. Neymeyer agreed that would be acceptable. If there are sprinklers in any of the buildings, there may be further hydrant requirements for the support FDC's.

Chief of Police, Bob Ray, asked for clarification on the plan for a drive-thru lane.

Mr. Simic answered yes; they may include a coffee shop.

Mr. Ray expressed concerns for any traffic backing up to the road, but noted with the current plan they appear to have sufficient room. He asked if the right-in right-out will include any triangle curb to force traffic.

Mr. Keyes speculated that a curb wouldn't be necessary because the street is one-way.

Mr. Ray explained that there is an existing drive way across the street and he would like to prevent drivers from trying to cut across.

Mr. Keyes responded that was a fine idea, but will let ODOT make the determination.

Public Works Director, Mark Crowell, asked if the applicants have any plans for the Welcome to Cornelius sign.

Mr. Simic answered that the sign is not in an easement, but the current plan is to not touch the sign. He asked if the city would like to move the sign.

Mr. Crowell answered the city is at the applicant's leisure on that decision. He explained the agreement with the previous lot owners. He expressed appreciation for the sign for the city, but acknowledged that it isn't a big deal if the applicant's choose to remove it.

City Manager, Peter Brandom, expressed wishes to preserve the sign. He added that he would like to see vegetation around it, as a gateway to the city.

Nathan added that they would like to do something nice around the sign. The current trees behind the sign are problematic for visibility.

Mr. Crowell reiterated that it is not the City's property and the city has no control in what is done with the sign. If the applicants are interested, the city would enter some partnership to determine what to do with the sign.

Mr. Nathan asked if there is anything special about the sign's location and if the sign could be moved to the eastern end of the property.

Mr. Crowell answered that the city is open to any suggestion. He doesn't believe it impedes visibility for traffic where it is at.

Mr. Simic explained they weren't sure what would be required from ODOT when making the design. When a more detailed plan is made, with everything in consideration, they will have a better idea what landscaping will look like.

Mr. Crowell noted the city wants the All American City and Blue Star City signs.

Mr. Brandom thanked the applicants for choosing Cornelius for their development. He expressed concern for the garbage removal from such a narrow property.

Mr. Mead added that if the businesses on their lot include a restaurant or coffee shop they will need a covered trash enclosure. That is a CWS standard to keep storm water out. It would also require a grease interceptor.

Project Manager, Kevin Oppenlander, had no comments.

Permit Specialist, Susan Rush, explained her role in the development process. She will calculate taxes and fees later in the process.

Mr. Franz reiterated that the applicants will need to include a detailed plan for a trash enclosure. He will be looking for function and ease of access. The city's municipal code covers safe internal circulation and promoting pedestrian connectivity from the sidewalks. On the current site plan, there is one pedestrian connection. He recommends adding a secondary pedestrian access. In the notes provided to the applicant, he will include the approved site plan for the development to the east, a six court sport facility. The other development's drive way abuts the eastern property line. As part of their approval they were asked to provide crossover easements. Their parking lot is

designed to provide vehicle connectivity between the two properties. The city asks that the applicants provide that connection on the site plan where possible.

Mr. Simic asked if the courts will be indoors.

Mr. Franz answered yes. The project is called Kem Hoops. The development has a secondary access to the south, back by the corner of the applicant's future parking lot. For any coffee shop, when designing it, the applicants will need to consider the city's parking code. The parking code requires ten vehicle stacking per service window. When the applicant's apply for a site plan, they will want to delineate the vehicle stacking for the drive up widow. That may affect the circulation on the back half of the building. The back may have to be one-way circulation. The city code requires 12 feet internal drive aisles for a one-way and 24 feet for two-way. The application will need to include directional arrows to show internal circulation. The city code has a minimum and maximum parking allowances, including bicycle parking. The current plan is over parked. A new plan will need to include bicycle parking. Up to 25% of internal parking can be compact spaces. A standard parking space is 9x20. Compact spaces at 8x16. The applicants can request a 10% parking reduction based on the proximity to a bus stop. A detailed landscaping plan is required, with plans for irrigation on the site. A lighting plan is required, with details on the light fixtures and photometric plan to ensure light is not going into the adjacent right-of-ways or abutting properties. There is a county-wide approved Transportation Development Tax (TDT). TDT fees are calculated based on site use and square footage. For a specialty retail location (code 814) at \$13,268 per 1,000 square feet, the estimated TDT will be \$167,000. The county typically increases that amount on July 1st of each year. That is due at the time of building permits. Applicants can choose to defer it, or set up a bank option with the city. He will include, in the packet shared with the applicants, checklists for everything that will be needed.

Mr. Simic asked if there are any further requirements for reports or studies.

Mr. Keyes answered a traffic study will not be required. The city knows the system has capacity for the proposed development.

Mr. Simic asked a question regarding the water line.

Mr. Keyes replied that he can share plans for the water and sewer lines. He recommends sending him an email and he will share those plans.

Mr. Franz encouraged the applicants to bring any questions, or site plan updates, to city staff. The staff can offer comments and review changes. He wants to help the applicants submit the best possible proposal.

Mr. Franz concluded the meeting, promising to provide comments and minutes within two weeks as previously stated

Memo

Subject: Preliminary Engineering Comments for Proposed Retail on SE Corner of 1st and Baseline

Date: October 25, 2022

By: Terry, Keyes, P.E., City Engineer

These comments are based on existing conditions on the site.

The comments are preliminary and designed to help in creating a final design that can be considered as part of the land use process. While the comments should not be interpreted as the final engineering comments on the development, these comments attempt to cover all major public infrastructure, erosion control, and stormwater runoff requirements related to development of this site.

General

The site consists of a 2.3 acre parcel at the southeast corner of Baseline and 1st Avenue.

All plans for public improvements must be designed by a registered professional engineer. Bonding for public improvements is typically required to ensure the improvements are completed in a satisfactory manner. Improvement plans for Baseline must be approved by both the City and Oregon Department of Transportation (ODOT). ODOT requires its own permits for work in their right-of-way. The timelines for ODOT review and permitting is typically longer than the city's timelines.

Street

Baseline

The frontage along Baseline is unimproved with a combination bike lane/shoulder adjacent to a road-side ditch. Street lights are mounted on PGE power poles. The overhead power lines on the south side of the street include PGE transmission lines near the top of the existing poles and PGE distribution lines midway up the poles. The poles also appear to support telecommunication lines.

Frontage improvements required by the City include:

- **Bike lane**
- **Concrete curb and gutter**
- **6-foot parkway strip with street trees meeting the City's Public Works Standards (see note below regarding street trees)**
- **6-foot concrete sidewalk**
- **Cobra-head street lights on their own poles**

- **Undergrounding all overhead lines, except the PGE transmission lines**
- **Driveways entering Baseline shall meet the Cornelius Standard Detail for a Commercial Driveway with a Parkway Strip (Detail S-22)**

A bus stop currently exists on the SE corner of Baseline and 1st. No special accommodation is required by the City for this bus stop.

As an ODOT road, ODOT controls access to Baseline. **The applicant will need to gain permission from ODOT for the proposed access onto Baseline.** Also, ODOT's archaic view of urban street trees may prevent their planting along some or all of the frontage. If ODOT prohibits street trees in the parkway strip, then the street trees shall be planted on the south side of the sidewalk, if possible.

1st Avenue

The frontage along 1st is improved with a concrete curb and gutter and a concrete curb-tight sidewalk. Two driveway drops also exist along this frontage.

Street lights are mounted on PGE power poles on the west side of 1st. No overhead power lines exist on the east side of the 1st.

The applicant proposes a driveway onto 1st approximately midway between Baseline and the railroad tracks. This is acceptable to the City.

Frontage improvements required by the City to 1st include:

- **Driveways entering 4th shall meet the Cornelius Standard Detail for a Commercial Driveway with Curb-tight Sidewalk (Detail S-21).**
- **Existing driveway drops that are not used shall be replaced with curb/gutter and sidewalk.**
- **Street trees meeting the City's Public Works Standards shall be placed along 1st on the east side of the sidewalk.**

Water

A new 8-inch C900 water main exists on the north side of Baseline from the City boundary to Hydrant #200 in the drawing below. This line was installed by the Carl's Jr. development a year ago and connects to a 12-inch public main in Adair Street. However, from Hydrant #200 to 4th Avenue, the water main is a substandard 4" cast iron line.

The applicant is required to replace the substandard water main along the Baseline frontage with an 8" C900 pipe from Hydrant #200 to their eastern property boundary. As the parcels to the east on both sides of Baseline development, this line will be upgraded to current standards.

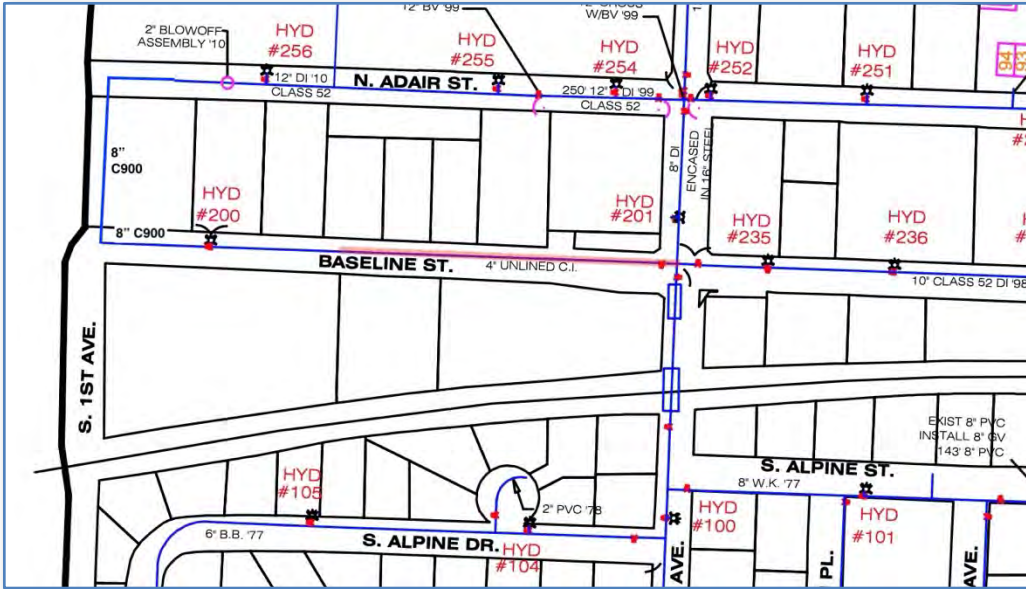

One fire hydrant exists (#200) on the north side of Baseline, as shown above. **The applicant will be required to install a new hydrant on the south side of Baseline, ideally toward the eastern edge of their frontage.** The Fire Department may determine that hydrants, in addition to a new one mentioned above, are needed.

Sanitary Sewer

A variety of sanitary sewers surround the site as shown in the adjacent drawing. Along the Baseline frontage and on 1st is an 8" public sanitary sewer. This sewer primarily serves Forest Grove and goes to a pump station at 1st Avenue and the railroad. This 8" line does NOT have capacity for the site.

A 10" public sewer exists on the north side of Baseline and drains to the east. This line does have capacity for the site. **Therefore, the site shall connect to the 10" main flowing east in Baseline.**

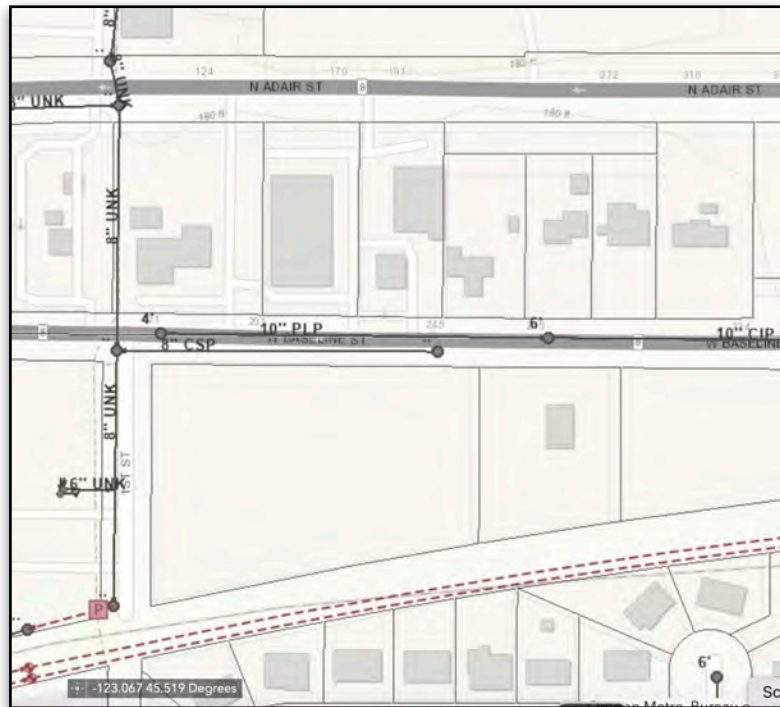

Stormwater

Conveyance

Before Walmart was constructed 14 years ago, stormwater runoff in the basin north of the railroad all flowed through a single culvert under the railroad. This is shown as point A in the drawing below. This routing of stormwater caused period flooding problems in the downstream neighborhood because the system lacks the capacity for handling all the runoff north of the railroad.

To deal with the additional stormwater flows from the Walmart site north of Adair, Walmart constructed a stormwater bypass pipe from the railroad to Heather Street along the Cornelius/Forest Grove boundary. The bypass goes under the railroad at point B. A control manhole at point C allows the city to split stormwater flows between the two routes under the railroad. Over the past 14 years, this system has successfully eliminated flooding in the neighborhoods to the south.

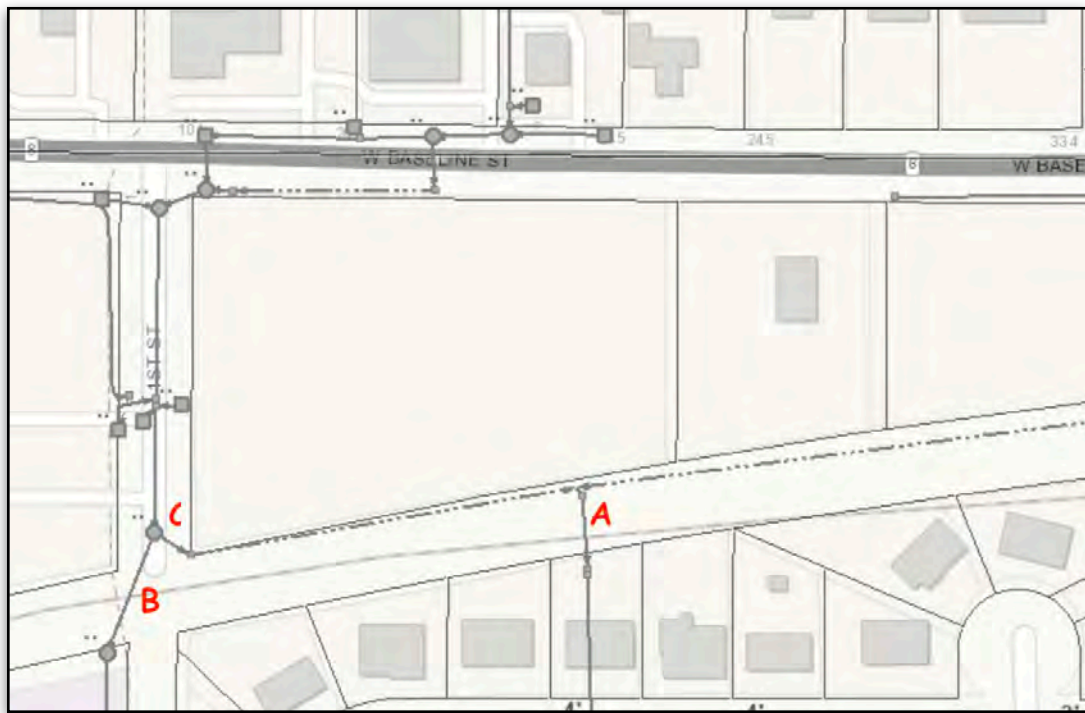

Stormwater runoff from this site shall be discharged into the existing storm sewer on 1st Avenue north of the control manhole C.

Treatment, Detention, and LIDA

Stormwater runoff from all new development in urban Washington County must be treated and detained in accordance with Clean Water Services (CWS) Standards. The CWS requirements consist of three parts.

- 1) *Treatment* – All runoff from new impervious surfaces must be treated before release into the public storm system. Treatment for commercial sites like this typically entails use of biofiltration swales, rain gardens, or stormwater filters
- 2) *Hydromodification or Detention* – This requirement is based on a series of factors. These factors and their ratings for this site are:

Risk – low

Development Class – developed area

Project Size – large (over 80,000 sq.ft.)

These criteria place the project in CWS's *Category 2*. Category 2 projects require significant detention as spelled out in the CWS Design and Construction Standards. Detention is typically provided by underground pipes or ponds.

- 3) *Low Impact Development Approach (LIDA)* – Projects must also incorporate some type of LIDA or green approach to stormwater control. Surface stormwater facilities such as swales and detention ponds meet the LIDA requirement. Other approaches that meet LIDA include: pervious pavement and green roofs.

Therefore, the project will need to meet the CWS requirements for treatment, hydromodification, and LIDA.

Service Provider Letter

The applicant must obtain a *Service Provide Letter (SPL)* from Clean Water Services. The SPL will determine if wetlands exist on or adjacent to the site and, if they do, will specify the vegetated corridor or buffer requirements for the site.

The ditch along the south edge of the site may qualify as a wetland/vegetated corridor.

Erosion Control

An erosion control plan is required for this project. Since 1 acre or more of land will be disturbed, the erosion control plan will need to meet the requirements for a 1200-CN permit.



Oregon

Kate Brown, Governor

Department of Transportation

Region 1 Headquarters
123 NW Flanders Street
Portland, Oregon 97209
(503) 731.8200
FAX (503) 731.8259

11/10/22

ODOT #12755

ODOT Response

Project Name: Cornelius Office and Retail Multi-Use Center	Applicant: Melissa Slotemaker
Jurisdiction: City of Cornelius	Jurisdiction Case #: PAC-16-22
Site Address: S 1st St and W Baseline St, Cornelius, OR 97113	State Highway: Baseline St (OR 8)

The site of this proposed land use action is adjacent to Baseline St (OR 8). ODOT has permitting authority for this facility and an interest in ensuring that this proposed land use is compatible with its safe and efficient operation. **Please direct the applicant to the District Contact indicated below to determine permit requirements and obtain application information.**

COMMENTS/FINDINGS

The applicant proposes two buildings for office (4,800SF) and retail (11,400SF) use. The site plan shows access to 1st Ave and to Baseline St (OR 8). In order to comply with ODOT's Access Management Rule and spacing standards, a State Highway Road Approach Permit is required for access to the State highway as per OAR 734.51. ODOT will only consider vehicular access to the site further towards the eastern property line. ODOT will consider an emergency "special use" access at the proposed location with documentation from the fire department.

ODOT recommends the city require frontage improvements consistent with the Transportation System Plan and ODOT/ADA standards. Right of way should be donated to ODOT for all public improvements. The posted speed is over 35mph so ODOT will not permit trees in the planter strip for safety reasons. Low shrubs are acceptable.

All alterations within the State highway right of way are subject to the ODOT Highway Design Manual (HDM) standards. Alterations along the State highway but outside of ODOT right-of-way may also be subject to ODOT review pending its potential impact to safe operation of the highway. If proposed alterations deviate from ODOT standards a Design Exception Request must be prepared by a licensed engineer for review by ODOT Technical Services. Preparation of a Design Exception request does not guarantee its ultimate approval. Until more detailed plans have been reviewed, ODOT cannot make a determination whether design elements will require a Design Exception.

Note: Design Exception Requests may take up to 3 months to process.

All ODOT permits and approvals must reach 100% plans before the District Contact will sign-off on a local jurisdiction building permit, or other necessary requirement prior to construction.

ODOT RECOMMENDED LOCAL CONDITIONS OF APPROVAL

Frontage Improvements and Right of Way

- Curb, sidewalk, and cross walk ramps shall be constructed as necessary to be consistent with local, ODOT and ADA standards.
- Right of way donated to ODOT as necessary to accommodate the planned cross section shall be provided. The deed must be to the State of Oregon, Oregon Department of Transportation. The ODOT District contact will assist in coordinating the transfer. ODOT should provide verification to the local jurisdiction that this requirement has been fulfilled. The property owner must be the signatory for the deed and will be responsible for a certified environmental assessment of the site prior to transfer of property to the Department.

Note: It may take up to **3 months** to transfer ownership of property to ODOT.

Access to the State Highway

- A State Highway Approach Road Permit from ODOT for access to the state highway for the proposed use is required. Truck turning templates shall be provided as needed to ensure vehicles can enter and exit the approach safely. Site access to the state highway is regulated by OAR 734.51. For application information go to <http://www.oregon.gov/ODOT/HWY/ACCESSMGT/Pages/Application-Forms.aspx>.

Note: It may take **2 to 3 months** to process a State Highway Approach Road Permit.

- The applicant shall record cross-over access easements to the adjacent properties with state highway frontage with the County Assessor to facilitate future shared access. Shared access will improve highway safety by reducing potential conflicts between vehicles and between vehicles and pedestrians and bicyclists at closely spaced driveways and will implement ODOT Access Management Program goals.

Permits and Agreements to Work in State Right of Way

- An ODOT Miscellaneous Permit must be obtained for all work in the highway right of way. When the total value of improvements within the ODOT right of way is estimated to be \$100,000 or more, an agreement with ODOT is required to address the transfer of ownership of the improvement to ODOT. An Intergovernmental Agreement (IGA) is required for agreements involving local governments and a Cooperative Improvement Agreement (CIA) is required for private sector agreements. The agreement shall address the work standards that must be followed, maintenance responsibilities, and compliance with ORS 276.071, which includes State of Oregon prevailing wage requirements.

Note: If a CIA is required, it may take up to **6 months** to process.

- Illumination within the ODOT right of way must be in accordance with AASHTO illumination standards and the ODOT Lighting Policy and Guidelines, which states that local jurisdictions must enter into an Intergovernmental Agreement (IGA) with ODOT wherein the local jurisdiction is responsible for installation, maintenance, operation, and energy costs.

- ☒ An ODOT Miscellaneous Permit is required for connection to state highway drainage facilities. Connection will only be considered if the site's drainage naturally enters ODOT right of way. The applicant must provide ODOT District with a preliminary drainage plan showing impacts to the highway right of way.

A drainage study prepared by an Oregon Registered Professional Engineer is usually required by ODOT if:

1. Total peak runoff entering the highway right of way is greater than 1.77 cubic feet per second; or
2. The improvements create an increase of the impervious surface area greater than 10,758 square feet.

Please send a copy of the Land Use Notice to:

ODOT Region 1 Planning
Development Review
123 NW Flanders St
Portland, OR 97209

ODOT_R1_DevRev@odot.oregon.gov

Development Review Planner: Marah Danielson	503.731.8258 Marah.b.danielson@odot.oregon.gov
District Contact: District 2B	D2bup@odot.oregon.gov

Exhibit H: Neighborhood Meeting Documentation

May 19, 2023



**Ref: Neighborhood Meeting
1st Avenue and Baseline Street Partition and Commercial Buildings**

Dear Neighbor/Property Owner:

AKS Engineering & Forestry, LLC is holding a neighborhood meeting regarding a ±2.32-acre property located at the southeast intersection of W Baseline Street and S 1st Avenue in the City of Cornelius. The property is described as Washington County Assessor's Map 1S304BB, Tax Lot 300, and has a Highway Commercial (C-2) zoning designation per the City Comprehensive Plan and Zone Map. The project involves partitioning the property to create two parcels intended for commercial development. A Site Development Review is planned to be submitted in conjunction with the partition application for a new commercial development on Parcel 1 of the planned partition.

Prior to applying to the City of Cornelius, we would like to take the opportunity to discuss the project in more detail with you. The purpose of this meeting is to provide a forum for surrounding property owners/residents to review and discuss the project before the application is submitted to the City. We will attempt to answer questions relevant to meeting development standards consistent with the City of Cornelius' Municipal code.

Pursuant to Cornelius Municipal Code Chapter 18.10.030, you are invited to attend a meeting on:

**June 13, 2023, at 6:00 pm
Cornelius Public Library, Walters Community Room
1370 N Adair Street
Cornelius, OR 9713**

Please note this meeting will be an informational meeting based on preliminary plans. These plans may be altered prior to submittal of the application to the City. Depending upon the type of land use action required, you may receive official notice from the City of Cornelius inviting you to participate with written comments and/or providing you an opportunity to attend a public hearing.

I look forward to discussing this project with you. If you have questions, but will be unable to attend, please feel free to call me at 503-563-6151 or email me at vermilyas@aks-eng.com.

Sincerely,
AKS ENGINEERING & FORESTRY, LLC

A handwritten signature in black ink that reads 'Sean Vermilya'.

Sean Vermilya
12965 SW Herman Road, Suite 100
Tualatin, OR 97062
503-563-6151 | vermilyas@aks-eng.com

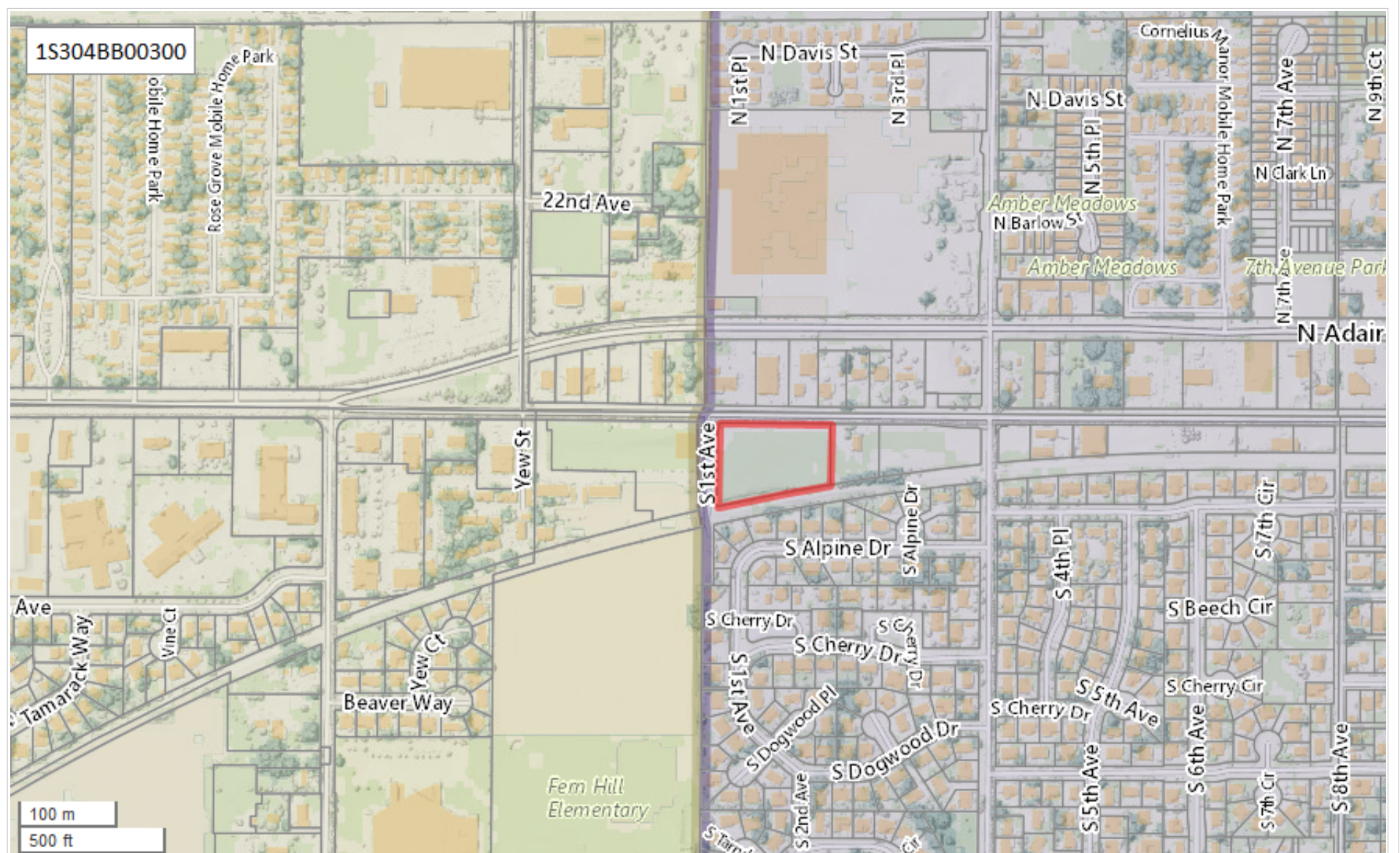

Data Resource Center

600 NE Grand Ave, Portland, OR 97232

503.797.1742 – drc@oregonmetro.gov

This Web site is offered as a public service, integrating various government records into a region-wide mapping system. The property assessment records are a multi-county integration of Clackamas, Multnomah and Washington County records. MetroMap blends each county's records into a common database on a quarterly basis. Therefore, to view each county's official records, go to their respective web sites or offices. The other MetroMap data are derived from city, county, state, federal and Metro sources. The metadata (data about the data) are included on this site, including the sources to be consulted for verification of the information contained herein. It describes some cases where Metro blends city and county records by generalizing the disparities. Metro assumes no legal responsibility for the compilation of multi-source government information displayed by Metro Map.

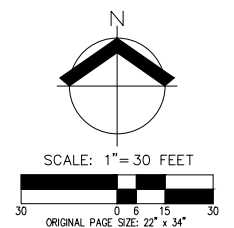
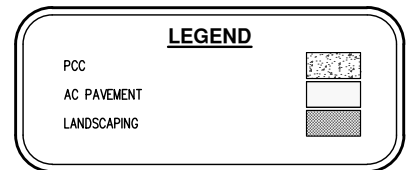

DATE: 06/13/2023 AKS JOB: 9656

AKS ENGINEERING & FORESTRY, LLC
 12965 SW HERMAN RD, STE 100
 TUALATIN, OR 97062
 503.563.6151
 WWW.AKS-ENG.COM



ENGINEERING • SURVEYING • NATURAL RESOURCES
 FORESTRY • PLANNING • LANDSCAPE ARCHITECTURE

PRELIMINARY SITE PLAN WITH AERIAL PHOTOGRAPH
**S 1ST AVENUE AND W BASELINE STREET
 COMMERCIAL PROJECT**

CORNELIUS, OR

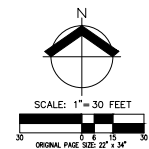
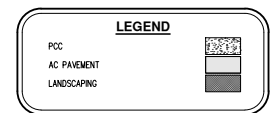
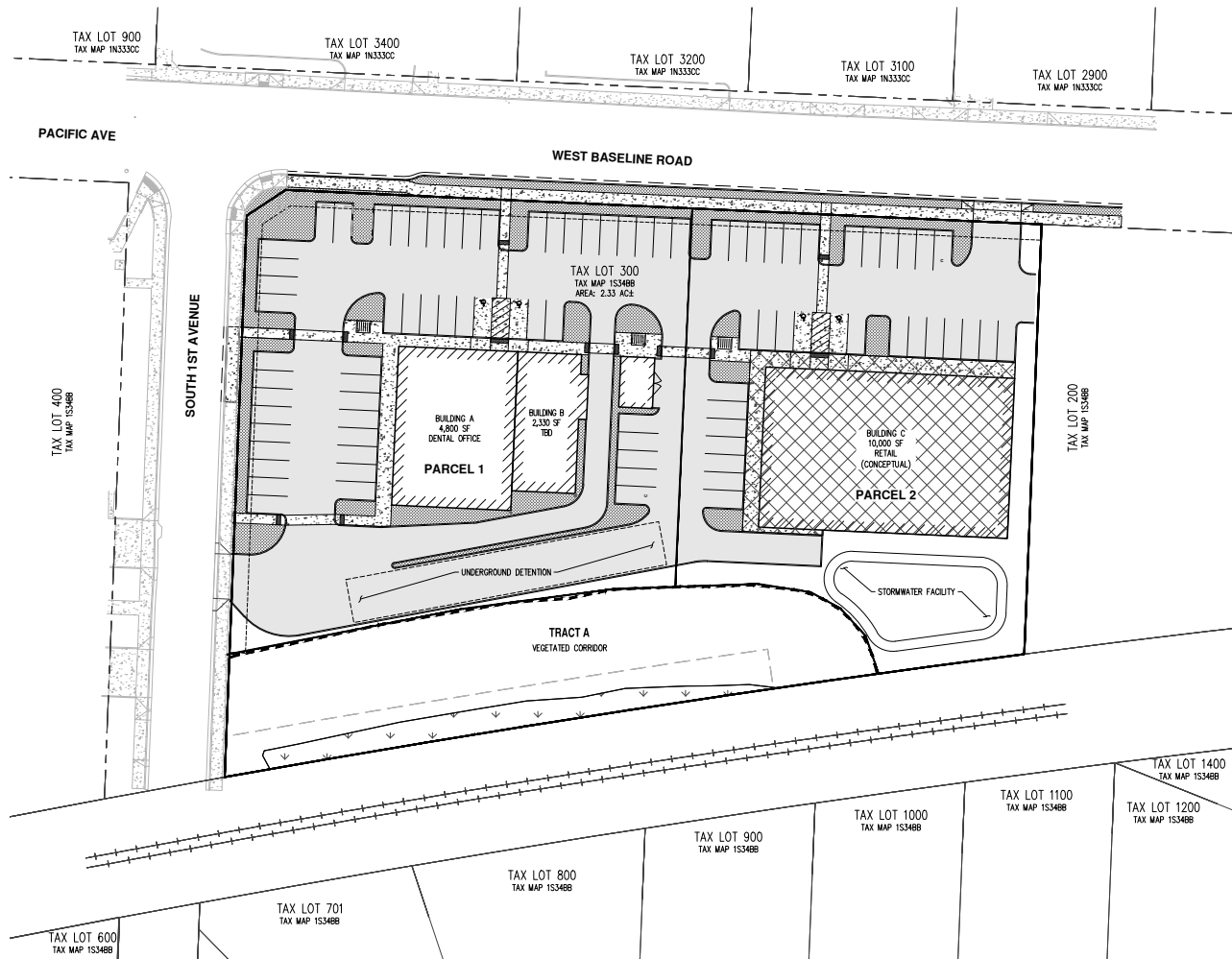

DATE: 06/13/2023 AKS JOB: 9656

AKS ENGINEERING & FORESTRY, LLC
12965 SW HERMAN RD, STE 100
TUALATIN, OR 97062
503.563.6151
WWW.AKS-ENG.COM



ENGINEERING • SURVEYING • NATURAL RESOURCES
FORESTRY • PLANNING • LANDSCAPE ARCHITECTURE

PRELIMINARY SITE PLAN
**S 1ST AVENUE AND W BASELINE STREET
COMMERCIAL PROJECT**

CORNELIUS, OR

u



AKS ENGINEERING & FORESTRY, LLC
12965 SW Herman Road, Suite 100, Tualatin, OR 97062
P: (503) 563-6151 F: (503) 563-6152

OFFICES IN: TUALATIN, OR - VANCOUVER, WA - SALEM-KEIZER, OR

Project Name	Site Address/ Location
Meeting Date	Meeting Location
Meeting Time	Meeting Location Address

PLEASE PRINT CLEARLY

Printed Name	Full Mailing Address & Email Address	City, State	Zip Code	Phone #
Tyler Young	1254 Brookside Forest Grove OR	FG, OR	97116	503-318-4914
Brenda Ineson	PO Box 207 Connellus 97113 resources11c@gmail			503-820-1110
Ed Gilbertz	4450 Pacific Ave. Forest Grove 97116	F.G. OR	97116	Prime Time restaurant@gmail.com
Greg Jansen	4450 Pacific Ave Forest Grove 97116	F.G. OR	97116	503 357-3684



June 21, 2023

Neighborhood Meeting Summary: N 1st Avenue and W Baseline Street Partition and Site Design Review

Meeting Date: June 13, 2023

Time: 6:00 PM

Location: Walters Community Room, Cornelius Public Library

The following serves as a summary of the Neighborhood Meeting process. On May 19, 2023, property owners within 250 feet of the proposed development site were sent notification of the planned three-parcel Partition and Site Design Review applications. This notification included the project location, project details, and the neighborhood meeting date, time, and location.

On June 13, 2023, meeting presenters included Sean Vermilya and Cody Street of AKS Engineering & Forestry. The meeting began with a brief introduction by Sean Vermilya summarizing the project and the Partition and Site Design Review applications. Information about the City's review process and opportunities for public input were provided. Following the presentation, attendees were then given the opportunity to ask questions. The following topics were discussed:

- Access locations and impacts to adjacent properties.
- Anticipated uses in the planned commercial buildings.
- Development phasing across the three parcels.
- Planned development on adjacent properties to the west and east.
- Number of parking spaces and drive aisle design.

The meeting concluded at approximately 6:30 pm.

Sincerely,

AKS ENGINEERING & FORESTRY, LLC

A handwritten signature in black ink that reads 'Sean Vermilya'.

Sean Vermilya

12965 SW Herman Road, Suite 100 | Tualatin, OR 97062

P: 503.563.6151 | vermilyas@aks-eng.com

Exhibit I: ODOT Comments



Oregon

Tina Kotek, Governor

Department of Transportation

Transportation Region 1

123 NW Flanders St.

Portland, OR 97209-4012

(503) 731-8200

Fax: (503) 731-8259

8/3/23:

ODOT # 12755

ODOT Response

Project Name: Cornelius Office and Retail Center	Applicant: Cody Street, AKS Engineering
Jurisdiction: City of Cornelius	State Highway: Baseline St (OR 8)
Location: S 1 st St and W Baseline St	

The site of this proposed land use action is adjacent to Baseline St (OR 8). ODOT has permitting authority for this facility and an interest in ensuring that this proposed land use is compatible with its safe and efficient operation. The posted speed on the highway is 40 mph so no street trees will be permitted along the property frontage. **Please direct the applicant to the District Contact indicated below to determine permit requirements and obtain application information.**

COMMENTS/FINDINGS

The property is zoned Highway Commercial (C-2), is ±2.3 acres in size, and abuts the Portland & Western Railroad, 1st St and Baseline St (OR 8). The applicant is proposing 2 buildings with a mix of office and retail spaces on tax lot (TL) 300 with access to 1st St and Baseline St. There is an existing approved land use decision for TL 200 and 100 and it is unknown at this time whether the future development will rely on the standing land use decision. The applicant has provided a letter dated July 6, 2023 from the real estate agent of TL 200 and 100 indicating that these properties are still on the market. Based on this, ODOT assumes the future development will not be moving forward.

The applicant's proposed access along Baseline St meets ODOT's access spacing standard. The development will also provide a crossover access easement to Tax Lots 100 and 200. An Application for State Highway Approach will need to be submitted as part of this development.

During a recent meeting with the applicant, ODOT and the City of Cornelius, ODOT was concerned that, if the existing land use decision were to move forward for 100 and 200, the access spacing standard wouldn't be met and would increase possible collisions on OR 8. ODOT and city staff agree work together with any future development of the adjacent tax lots to reconstruct the access with a shared centerline at the property line between TL 300 and 200 to provide highway access to three lots.

ODOT supports the city requirements to bring the highway frontage up to current ODOT and city standards. The applicant should be required to verify that the existing ADA ramp at the intersection meets current ODOT/ADA standards. ODOT permits are required for access and all work in the highway right of way.

All alterations within the State highway right of way are subject to the ODOT Highway Design Manual (HDM) standards. Alterations along the State highway but outside of ODOT right-of-way may also be subject to ODOT review pending its potential impact to safe operation of the highway. If proposed alterations deviate from ODOT standards a Design Exception Request must be prepared by a licensed engineer for review by ODOT Technical Services. Preparation of a Design Exception request does not

guarantee its ultimate approval. Until more detailed plans have been reviewed, ODOT cannot make a determination whether design elements will require a Design Exception.

Note: Design Exception Requests may take **4 months or longer** to process.

All ODOT permits and approvals must reach 100% plans before the District Contact will sign-off on a local jurisdiction building permit, or other necessary requirement prior to construction.

ODOT RECOMMENDED LOCAL CONDITIONS OF APPROVAL

Frontage Improvements and Right of Way

- Curb, sidewalk, cross walk ramps bikeways and road widening shall be constructed as necessary to be consistent with local, ODOT and ADA standards.
- Right of way donated to ODOT as necessary to accommodate the planned cross section shall be provided. The deed must be to the State of Oregon, Oregon Department of Transportation. The ODOT District contact will assist in coordinating the transfer. ODOT should provide verification to the local jurisdiction that this requirement has been fulfilled. The property owner must be the signatory for the deed and will be responsible for a certified environmental assessment of the site prior to transfer of property to the Department.

Note: It may take up to **6 months or longer** to transfer ownership of property to ODOT.

Access to the State Highway

- A State Highway Approach Road Permit from ODOT for access to the state highway or written determination (e-mail, fax or mail acceptable) from ODOT that the existing approach(es) is/are legal for the proposed use is required. Truck turning templates shall be provided as needed to ensure vehicles can enter and exit the approach safely. Site access to the state highway is regulated by OAR 734.51. For application information go to <http://www.oregon.gov/ODOT/HWY/ACCESSMGT/Pages/Application-Forms.aspx>.

Note: It may take up to **6 months to 1 year or longer** to process a State Highway Approach Road Permit depending on the level of complexity of the project and plan review timeline.

- The applicant shall record cross-over access easements to the adjacent properties (TL 200 and TL 100) with state highway frontage with the County Assessor to facilitate future shared access. Shared access will improve highway safety by reducing potential conflicts between vehicles as well as between vehicles and vulnerable road users (pedestrians and bicyclists) at closely spaced driveways and will implement ODOT Access Management Program goals.

Permits and Agreements to Work in State Right of Way

- An ODOT Miscellaneous Permit must be obtained for all work in the highway right of way. When the total value of improvements within the ODOT right of way is estimated to be \$100,000 or more, an agreement with ODOT is required to address the transfer of ownership of the improvement to ODOT. An Intergovernmental Agreement (IGA) is required for agreements involving local governments and a Cooperative Improvement Agreement (CIA) is required for private sector agreements. The agreement shall address the work standards that must be followed, maintenance responsibilities, and compliance with ORS 276.071, which includes State of Oregon prevailing wage requirements.

Note: If a CIA is required, it may take **6 months or longer** to process.

☒ Illumination within the ODOT right of way must be in accordance with AASHTO illumination standards and the ODOT Lighting Policy and Guidelines, which states that local jurisdictions must enter into an Intergovernmental Agreement (IGA) with ODOT wherein the local jurisdiction is responsible for installation, maintenance, operation, and energy costs.

☒ An ODOT Utility Permit is required for connection to state highway drainage facilities. Connection will only be considered if the site's drainage naturally enters ODOT right of way. The applicant must provide ODOT District with a preliminary drainage plan showing impacts to the highway right of way.

A drainage study prepared by an Oregon Registered Professional Engineer is usually required by ODOT if:

1. Total peak runoff entering the highway right of way is greater than 1.77 cubic feet per second; or
2. The improvements create an increase of the impervious surface area greater than 10,758 square feet.

Please send a copy of the Notice of Decision including conditions of approval to:

ODOT Region 1 Planning
Development Review
123 NW Flanders St
Portland, OR 97209

[ODOT R1 DevRev@odot.oregon.gov](mailto:ODOT_R1_DevRev@odot.oregon.gov)

Development Review Planner: Marah Danielson	503.731.8258, marah.b.danielson@odot.oregon.gov
District Contact: District 2B Permits	D2bup@ODOT.oregon.gov