

Filename: L:\Projects\74000\74217\4217-000\Civil\CAD\Working\Exhibits\74217_000_CI_AUTOTURN1.dwg User: Peter Reich CAD Plot Date/Time: 6/6/2022 4:05:19 PM Layout Tab: 1

DRAFT

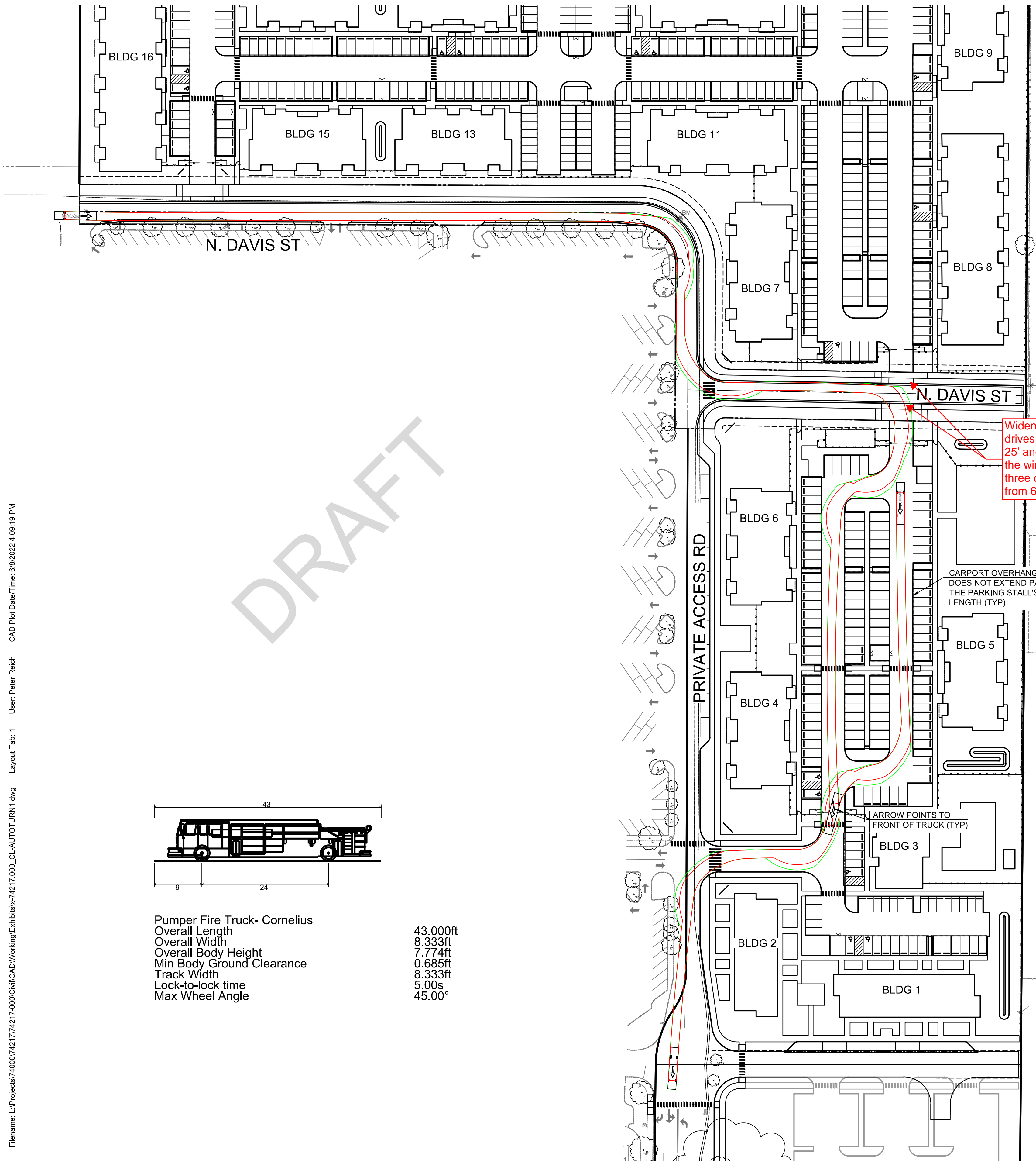

Widened these 2 drives from 24' to 25' and increased the wings on all three driveways from 6' to 8'.

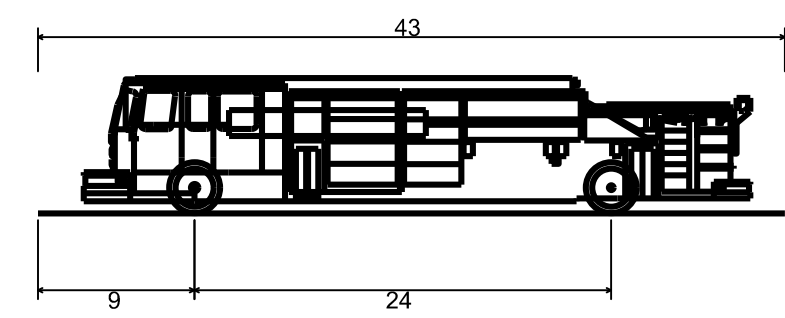

Pumper Fire Truck- Cornelius
Overall Length 43.000ft
Overall Width 8.333ft
Overall Body Height 7.774ft
Min Body Ground Clearance 0.685ft
Track Width 8.333ft
Lock-to-lock time 5.00s
Max Wheel Angle 45.00°

CARPORT OVERHANG DOES NOT EXTEND PAST THE PARKING STALL'S LENGTH (TYP)

ARROW POINTS TO FRONT OF TRUCK (TYP)

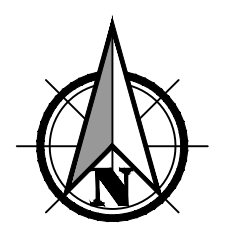

Scale 1" = 60'
0 30 60 120

CORNELIUS MULTI-USE - AUTOTURN EXHIBIT 1 - 6/7/2022

Filename: L:\Projects\74000742174217-000\Civil\CAD\Working\Exhibits\74217_000_CL-AUTOTURN2.dwg User: Peter Reich CAD Plot Date/Time: 6/8/2022 4:09:28 PM Layout Tab: 2

DRAFT

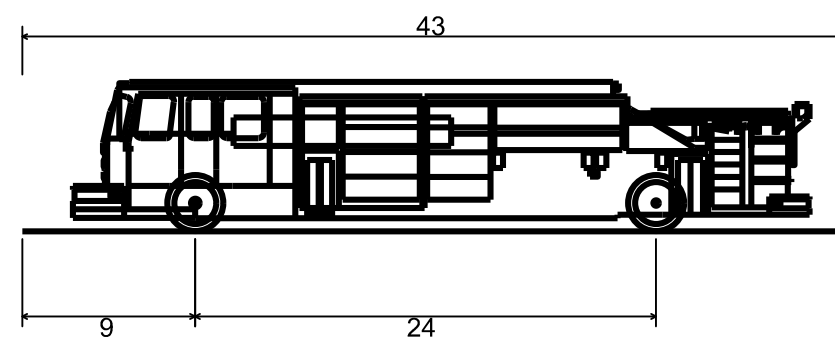

Pumper Fire Truck- Cornelius
Overall Length
Overall Width
Overall Body Height
Min Body Ground Clearance
Track Width
Lock-to-lock time
Max Wheel Angle

43.000ft
8.333ft
7.774ft
0.685ft
8.333ft
5.00s
45.00°

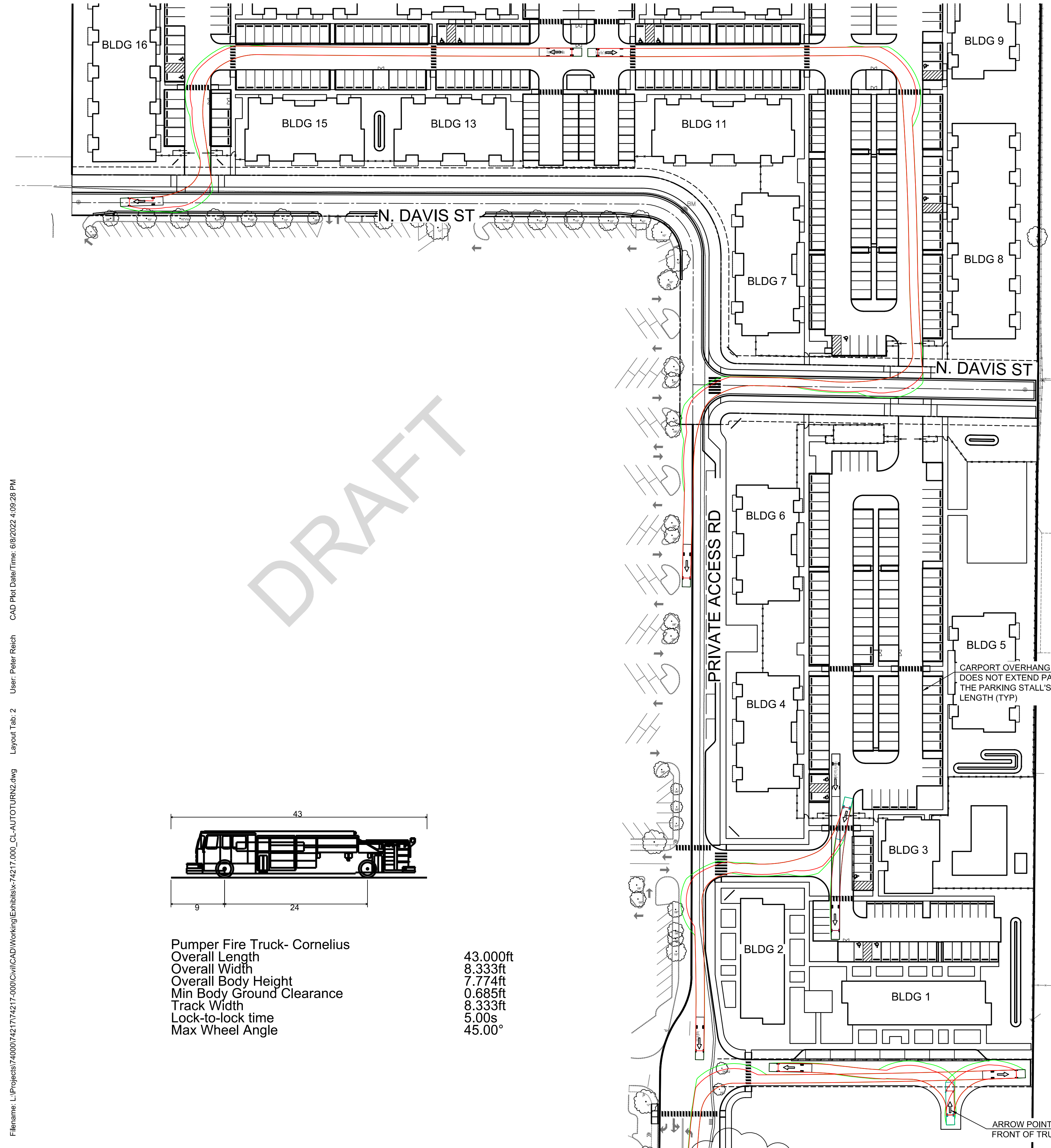

CORNELIUS MULTI-USE - AUTOTURN EXHIBIT 2 - 6/7/2022

